

REV	DATE	DRAWN/CHECKED	DESCRIPTION	PART NUMBER
A	04MAY93	ALC	PRN: S-1-03	F7-71
B	10NOV94	MSB	PRN: P2002-0790	
C	19OCT2002	AJH/DLH	PRN: P2002-0790	

**INCHES**

ALL DIMENSIONS WITHOUT TOLERANCES ARE FOR REFERENCE ONLY.

A3 PAPER  
 THIRD ANGLE PROJECTION

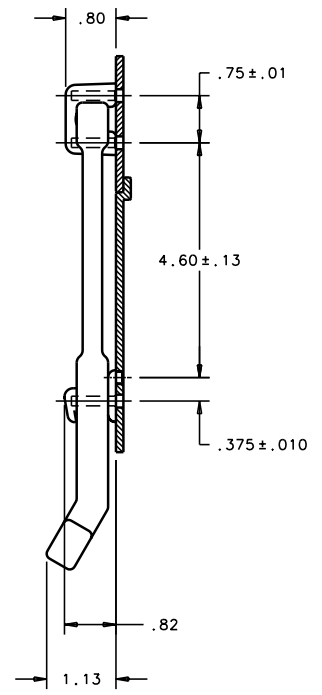
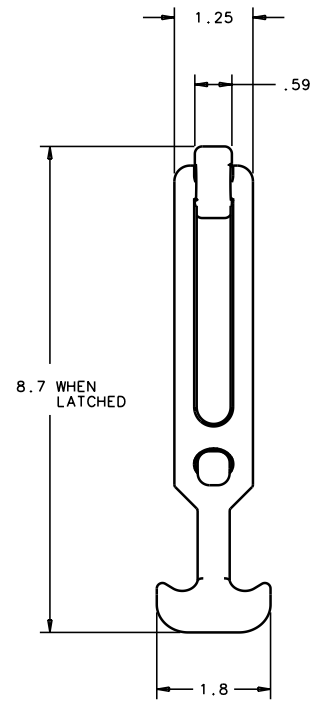
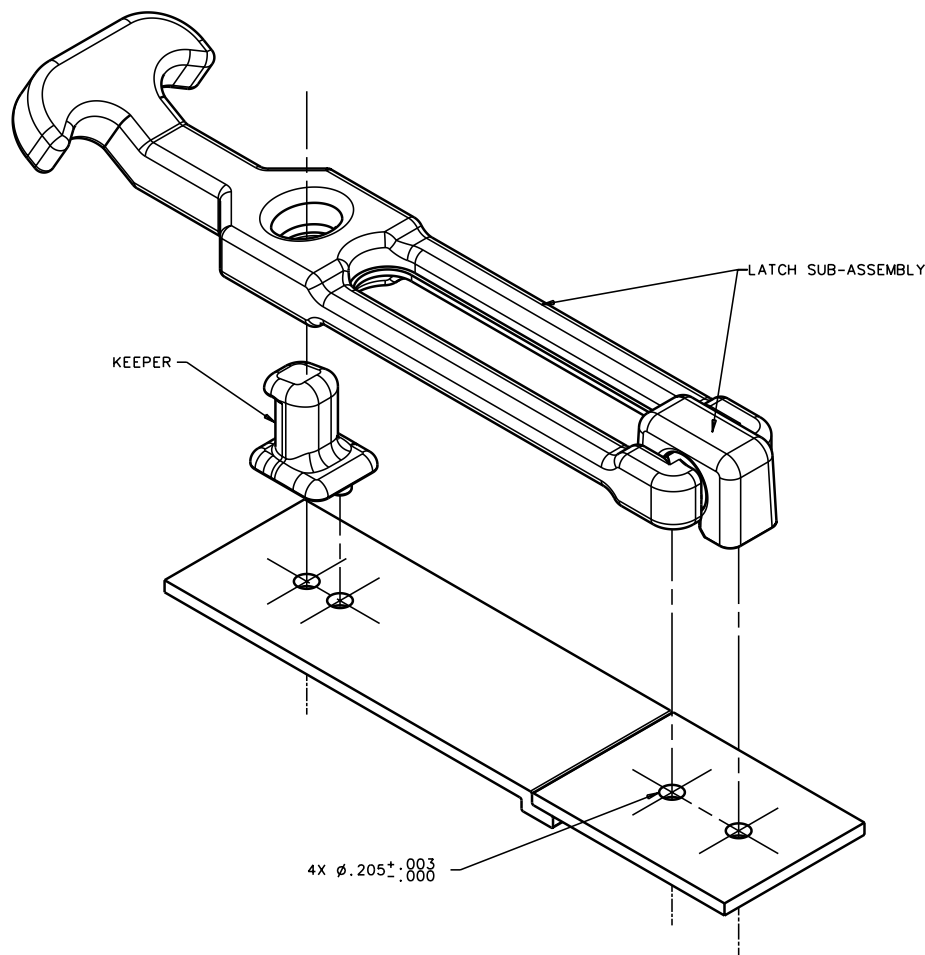

INSTALLED VIEWS  
 (SCALE .5:1)

- NOTES:
- LATCH ASSEMBLY CONSISTS OF:  
 SUB-ASSEMBLY:  
     HANDLE - TPE, BLACK  
     BRACKET - G.R., NYLON, BLACK.  
 KEEPER - G.R., NYLON, BLACK
  - LATCH SUB-ASSEMBLY, KEEPER, AND SCREWS SHIPPED SEPARATELY, BULK. FOR LATCHES PACKAGED ONE PER BAG, ADD -P TO PART NUMBER.
  - MOUNT USING (3) 10-24 THREAD SCREWS (NOT SUPPLIED).  
 SCEW LENGTH = PANEL THICKNESS PLUS .50.