

southco

PROPRIETARY ITEM - EXCEPT FOR USES EXPRESSLY GRANTED IN WRITING INFORMATION DISCLOSED HEREON IS CONFIDENTIAL AND ALL RIGHTS PATENT AND OTHERWISE ARE RESERVED BY SOUTHCO, INC.

FLEXIBLE DRAW LATCH - CONCEALED MOUNTING
(FRONT MOUNTED)

DATE	DRAWN	CHKD	SCALE	DRAWING NUMBER
9-24-90	pek		1:1	J-F7-53

REV	DATE	DRAWN/CHKD	DESCRIPTION	PART NUMBER
A	12JAN93	KPL	PRN: S-1-03	F7-53
B	16AUG96	ALC	PRN: F7-41	
C	19OCT2002	AJH/DLH	PRN: P2002-0790	
D	06SEP2016	CMS/JF	PRN: P2016-2050	

MILLIMETERS

ALL DIMENSIONS WITHOUT TOLERANCES ARE FOR REFERENCE ONLY.



THIRD ANGLE PROJECTION

A4 PAPER SIZE

NOTES:

- LATCH ASSEMBLY CONSISTS OF:
SUB-ASSEMBLY:
HANDLE - TPE, BLACK
BRACKET - GLASS REINFORCED NYLON, BLACK.
KEEPER - GLASS REINFORCED NYLON, BLACK
- LATCH SUB-ASSEMBLY AND KEEPER SHIPPED SEPARATELY, BULK. FOR LATCHES PACKAGED ONE PER BAG, ADD -P TO PART NUMBER.
- MOUNT USING (3) No. 10/M5 SCREWS OR 3/16 - 5mm RIVETS (NOT SUPPLIED).

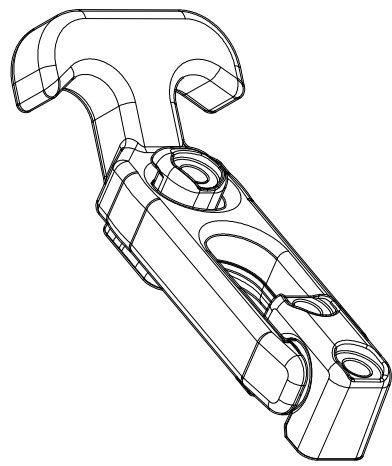
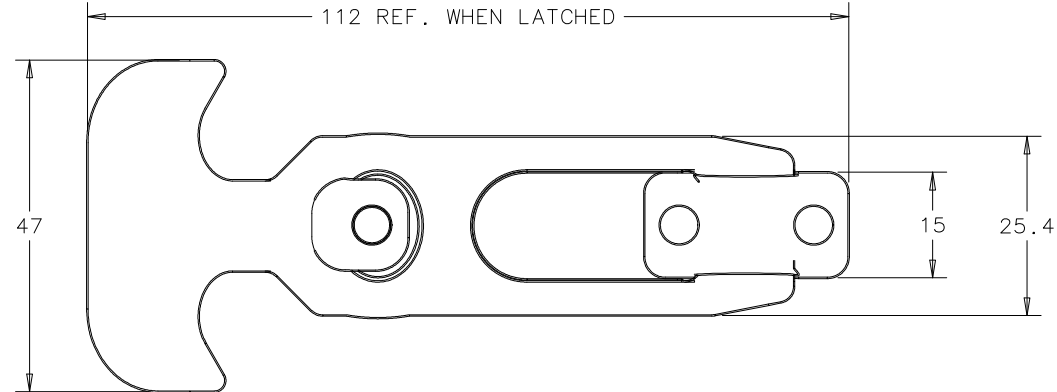

SCALE .75:1

