

# southco

PROPRIETARY ITEM - EXCEPT FOR USES EXPRESSLY GRANTED IN WRITING INFORMATION DISCLOSED HEREON IS CONFIDENTIAL AND ALL RIGHTS PATENT AND OTHERWISE ARE RESERVED BY SOUTHCO, INC.

## FLEXIBLE DRAW LATCH - CONCEALED MOUNTING (THREAD FORMING)

DATE	DRAWN	CHKD	SCALE	DRAWING NUMBER
29MAR2000	RMP		1:1	J-F7-54

REV	DATE	DRAWN/CHKD	DESCRIPTION	PART NUMBER
A	03MAY2002	AJH/DLH	PRN: P2002-0280	F7-54
B	19OCT2002	AJH/DLH	PRN: P2002-0790	

**MILLIMETERS**

ALL DIMENSIONS WITHOUT TOLERANCES ARE FOR REFERENCE ONLY.

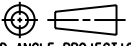
 **THIRD ANGLE PROJECTION**

**A4 PAPER SIZE**

- NOTES:**
- LATCH ASSEMBLY CONSISTS OF:  
SUB-ASSEMBLY:  
HANDLE - TPE, BLACK  
BRACKET - GLASS REINFORCED NYLON, BLACK.  
KEEPER - GLASS REINFORCED NYLON, BLACK  
SCREWS (3) - 18-8 STAINLESS, PASSIVATED.
  - LATCH SUB-ASSEMBLY, KEEPER, AND SCREWS SHIPPED SEPARATELY, BULK. FOR LATCHES PACKAGED ONE PER BAG, ADD -P TO PART NUMBER.
  - MOUNT USING (3) THREAD FORMING NUMBER 2 PHILLIPS RECESS, SCREWS (SOUTHCO SUPPLIED).  
MAX. INSTALLATION TORQUE 2.0 N-m

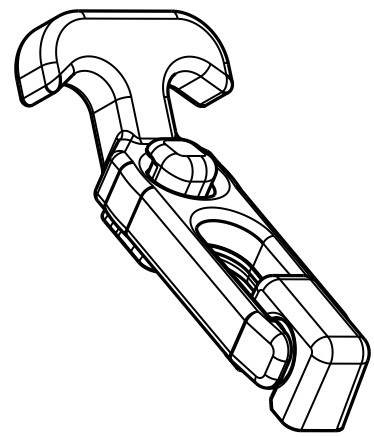
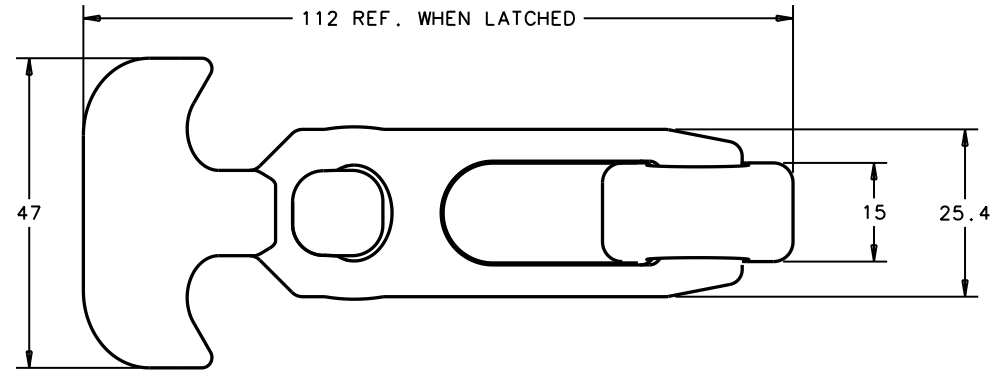

SCALE 3:4

