

southco

PROPRIETARY ITEM - EXCEPT FOR USES EXPRESSLY GRANTED IN WRITING INFORMATION DISCLOSED HEREON IS CONFIDENTIAL AND ALL RIGHTS PATENT AND OTHERWISE ARE RESERVED BY SOUTHCO, INC.

FLEXIBLE DRAW LATCH - CONCEALED MOUNTING (THREAD FORMING)

DATE	DRAWN	CHKD	SCALE	DRAWING NUMBER
24MAR2000	RMP		1:1	J-F7-55

REV	DATE	DRAWN/CHKD	DESCRIPTION	PART NUMBER
A	03MAY2002	AJH/DLH	PRN: P2002-0280	F7-55
B	19OCT2002	AJH/DLH	PRN: P2002-0790	

MILLIMETERS

ALL DIMENSIONS WITHOUT TOLERANCES ARE FOR REFERENCE ONLY.

THIRD ANGLE PROJECTION

A4 PAPER SIZE

- NOTES:
- LATCH ASSEMBLY CONSISTS OF:
SUB-ASSEMBLY:
HANDLE - TPE, BLACK
BRACKET - GLASS REINFORCED NYLON, BLACK.
KEEPER - GLASS REINFORCED NYLON, BLACK
SCREWS (3) - 18-8 STAINLESS, PASSIVATED.
 - LATCH SUB-ASSEMBLY, KEEPER, AND SCREWS SHIPPED SEPARATELY, BULK. FOR LATCHES PACKAGED ONE PER BAG, ADD -P TO PART NUMBER.
 - MOUNT USING (3) THREAD FORMING NUMBER 2 PHILLIPS RECESS SCREWS (SOUTHCO SUPPLIED).
MAX INSTALLATION TORQUE 2.0 N-m.

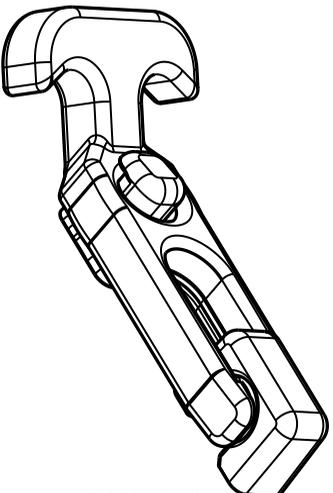
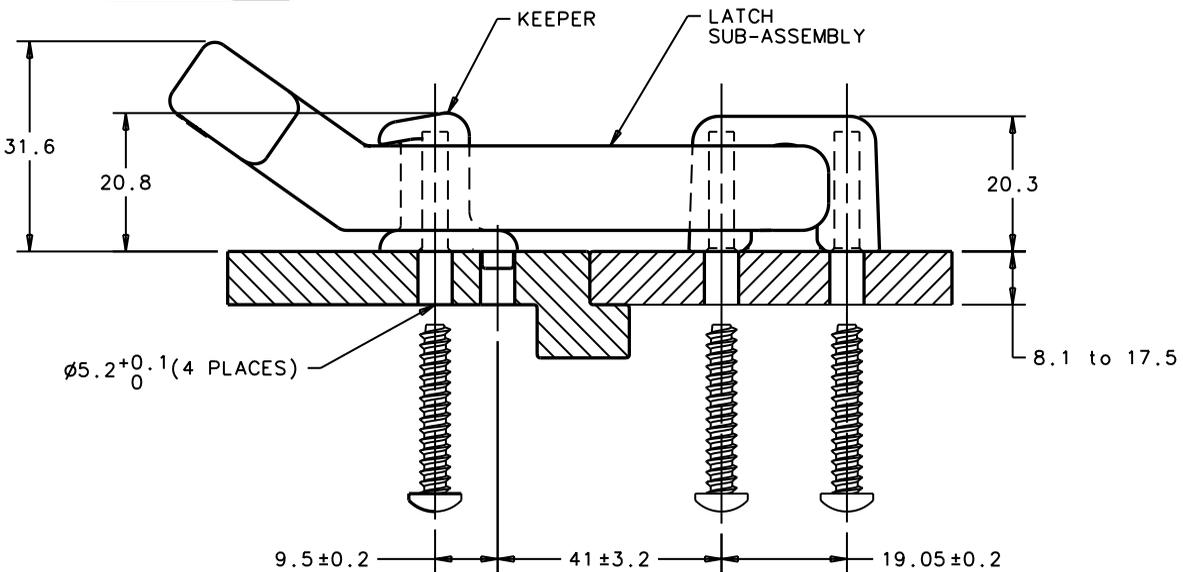
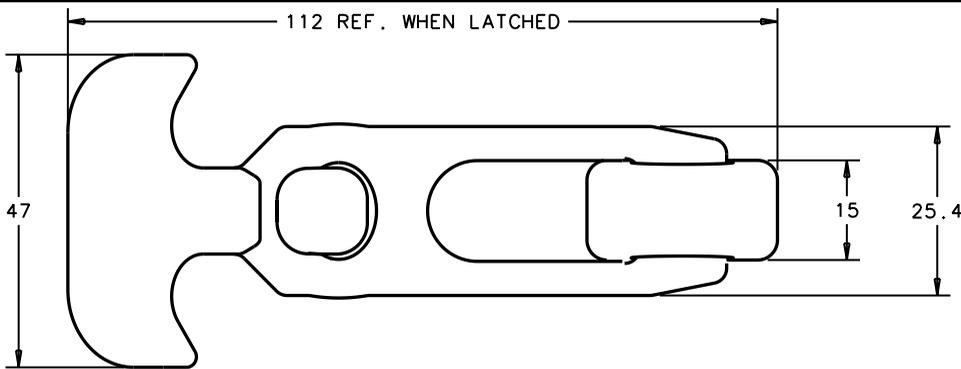

SCALE 3:4