

REV.	DATE	BY-CHKD	REVISIONS
B	15 JAN.93	KPL	PRN: S-1-03
C	09OCT96	SWD	PRN: S-93-23
D	08DEC98	JGK	PRN: 716A
E	07JUL99	SCK JSS	PRN: E3-806
F	16APR2012	CMS CDW	PRN: P2012-0498
G	29JAN2015	CMS MWD	PRN: P2015-0226

ASSEMBLY PART NO.	GRIP RANGE	PAWL OFFSET
E3-35-1X	0.31 - 0.93 or 2.47 - 3.00	1.08
E3-35-2X	0.86 - 1.47 or 1.93 - 2.55	0.54
E3-35-3X	1.39 - 2.00	NONE

THE ABOVE PART NUMBERS ARE TYPE "A" (TURN CLOCKWISE TO LATCH). FOR TYPE "B" ASSEMBLIES (TURN COUNTERCLOCKWISE TO LATCH), CHANGE THE THIRD DIGIT OF THE PART NUMBER FROM 3 TO 23. EXAMPLE: E3-235-15

COMPONENT	MATERIAL	FINISH
HOUSING	ZINC ALLOY	SEE FINISH TABLE
CAM	SPRING STEEL	ZINC IMMERSION COATING
SHAFT	SPRING STEEL	ZINC IMMERSION COATING
SPRING	STAINLESS STEEL	NATURAL
SLEEVE	SPRING STEEL	ZINC IMMERSION COATING
PIN	STEEL	ZINC PLATE, TRIVALENT CHROMATE PASSIVATE
RETAINING RING	STAINLESS STEEL	NATURAL
O-RING	BUNA-N	NATURAL
CAM	STEEL	ZINC PLATE, TRIVALENT CHROMATE PASSIVATE
NUT, HEX M10X1.5 (2)	STEEL	ZINC PLATE, TRIVALENT CHROMATE PASSIVATE
WASHER, STEEL (2)	SPRING STEEL	ZINC PLATE, TRIVALENT CHROMATE PASSIVATE
CAP	STAINLESS STEEL	SEE FINISH TABLE
BUSHING	ZINC ALLOY	SEE FINISH TABLE
SCREW/LOCKWASHER (2)	STEEL	ZINC PLATE, TRIVALENT CHROMATE PASSIVATE
GASKET	RUBBER IMPREGNATED VELLUM	NATURAL

### NOTES:

- OPERATION: 195° TURN OF KEY CAUSES PAWL TO ROTATE 75° THEN PULL UP 0.25.
- PAWL, NUTS, LOCKWASHERS, GASKET, AND SCREW ASS'LY'S SHIPPED UNASSEMBLED IN BAG WITH LATCH ASSEMBLY.
- INSTALLATION:
  - INSTALL GASKET OVER LATCH AND INSTALL LATCH IN DOOR. ATTACH USING M4 SCREW ASSEMBLIES (7mm HEX) 15 in-lb MAX. TIGHTENING TORQUE.
  - INSTALL JAM NUT, LOCKWASHER, PAWL, LOCKWASHER, AND JAM NUT ON SHAFT. ADJUST JAM NUTS TO POSITION PAWL AT CORRECT GRIP (WITH LATCH CLOSED). TIGHTEN JAM NUTS (180 in-lb MAX. TORQUE) USING TWO 17mm WRENCHES.

CAUTION: ADJUST PAWL SO THAT NO MORE THAN 70 in-lb TORQUE ON KEY IS REQUIRED TO CLOSE LATCH.

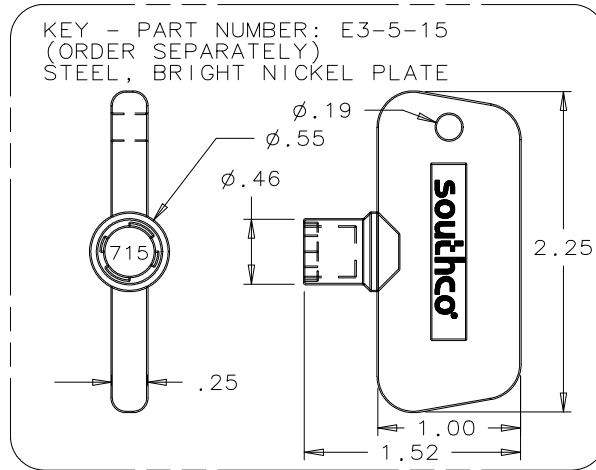

### X FINISH TABLE

- BRIGHT CHROMATE PLATE
- CARDINAL WHITE POWDER COAT
- BLACK POWDER COAT
- LIGHT GREY POWDER COAT
- SATIN SILVER POLYESTER POWDER COAT
- SILVER METALLIC URETHANE POWDER COAT

