

NOTES:

- A. OPERATION: 195° TURN OF KNOB CAUSES PAWL TO ROTATE 75° THEN UNLATCH.
 B. PAWL, NUTS, AND LOCKWASHERS SHIPPED UNASSEMBLED IN BAG WITH LATCH ASSEMBLY.
 C. INSTALLATION:
 1. INSERT LATCH INTO HOLE IN DOOR. CHECK FOR PROPER ORIENTATION AND OPERATION OF PAWL.
 2. INSTALL USING LOCKWASHER AND MOUNTING NUT (27mm ACROSS FLATS). RECOMMENDED TIGHTENING TORQUE 20 Nm.
 3. INSTALL JAM NUT, LOCKWASHER, PAWL, LOCKWASHER, AND JAM NUT ON SHAFT. ADJUST JAM NUTS TO POSITION PAWL AT CORRECT GRIP (WITH LATCH CLOSED). TIGHTEN JAM NUTS (18 Nm MAX. TORQUE) USING TWO 17mm WRENCHES.
 4. CAUTION:
 ADJUST PAWL SO THAT NO MORE THAN 7.9 Nm TORQUE ON KNOB IS REQUIRED TO CLOSE LATCH.
 D. CONTACT SOUTHCO FOR DETAILS ON ORDERING SEPARATE LOCK PLUGS.
 E. KEY CODE OPTION IS USED FOR ADDITIONAL KEY CODE LOCKS ABOVE THE FIRST KEY CODE. ADD THE THREE DIGIT KEY CODE TO THE END OF THE PART No. (FFF) WHEN THE KNOB STYLE = 52 OR 58.
 EXAMPLE: E3-158-15-002 IS FOR R002 KEY CODE. CONTACT SOUTHCO FOR DETAILS.

F. E3-VV59-XZ LOCK PLUG INSTALLATION:

1. THE LATCH MUST BE IN THE UNLATCHED AND UNLOCKED POSITION. IF THE LATCH WILL NOT ROTATE, SLIDE LOCK PAWL INSIDE KNOB TOWARDS DIMPLE ON KNOB, TO UNLOCKED POSITION. ROTATE LATCH TO UNLATCHED POSITION.
 2. TAKE NEW LOCK PLUG WITH THE RETAINING WAFER (LAST WAFER LOCATED AT BOTTOM OF THE LOCK) ORIENTED IN DIRECTION OF DIMPLE LOCATED ON SIDE OF KNOB (3 O'CLOCK POSITION FROM LOCK SYMBOL ON TOP OF KNOB).
 3. INSERT LOCK PLUG INTO KNOB AND REMOVE KEY.
 G. FOR LATCH SUBASSEMBLY AND HARDWARE PACKAGE PART NUMBERS, CONTACT SOUTHCO FOR DETAILS. REFER TO SUBASSEMBLY TRADE DRAWING J-E3-11-4.



PROPRIETARY ITEM - EXCEPT FOR USES EXPRESSLY GRANTED IN WRITING INFORMATION DISCLOSED HEREON IS CONFIDENTIAL AND ALL RIGHTS PATENT AND OTHERWISE ARE RESERVED BY SOUTHCO, INC.

WISE-ACTION™ LATCH - INTERNATIONAL SERIES
 KEY LOCKING AND NON-LOCKING WING KNOB ASSEMBLY

DATE	DRAWN/CHKD	SCALE	DRAWING NUMBER
19JUL2004	AAB	1:1	J-E3-11-2

X (PAWL TYPE)	GRIP RANGE	PAWL POSITION	PAWL OFFSET
1	11.4 - 27.2	FORWARD	27.4
2	25.4 - 41.1	FORWARD	13.7
3	38.9 - 54.6	STRAIGHT	NONE

REV	DATE	DRAWN/CHKD	DESCRIPTION
A	04OCT2004	AAB/AJH	PRN: P2004-1120
B	02NOV2004	AAB/RLR	PRN: P2004-1220
C	11MAR2005	MDY/RLR	PRN: P2005-0326
D	28JAN2015	CMS/MWD	PRN: P2015-0219
E	09APR2015	CMS/BGL	PRN: P2015-0641

MILLIMETERS
 ALL DIMENSIONS WITHOUT TOLERANCES ARE FOR REFERENCE ONLY.
 THIRD ANGLE PROJECTION
 B PAPER SIZE

- HOUSING STYLE**
 1 - TYPE A (TURN CLOCKWISE TO LATCH).
 22 - TYPE B (TURN COUNTERCLOCKWISE TO LATCH).

- FINISH TABLE**
- | |
|--|
| 4 - CARDINAL WHITE POWDER COAT |
| 5 - BLACK POWDER COAT |
| 6 - LIGHT GREY POWDER COAT |
| 7 - SATIN SILVER POLYESTER POWDER COAT |
| 8 - SILVER METALLIC URETHANE POWDER COAT |

KEY CODE OPTION (NOTE E)

- 002 - 2ND KEY CODE
 003 - 3RD KEY CODE
 004 - 4TH KEY CODE
 999 - 999TH KEY CODE

KEY OPTION (NOTE E)

- BLANK - (1) OVERMOLDED KEY
 A - (2) FLAT KEYS ON A RING
 B - KEY(S) NOT INCLUDED

KNOB STYLES (AND KEY CODES)

- 50 - NON LOCKING
 51 - LOCKING (CH751)
 52 - LOCKING (LS001)
 53 - LOCKING (LS001-125)
 54 - LOCKING (LS126-250)
 55 - LOCKING (LS251-375)
 56 - LOCKING (HL450)
 57 - LOCKING (14603)
 58 - SHUTTERED, REVERSIBLE (R001)
 59 - WITHOUT LOCK PLUG (NOTE D) (CUSTOMER INSTALLED)

ASSEMBLY PART No.
E3-VV WW-X Z-FFF K

HOUSING STYLE
 KNOB STYLE
 PAWL TYPE
 FINISH
 KEY CODE OPTION
 KEY OPTION

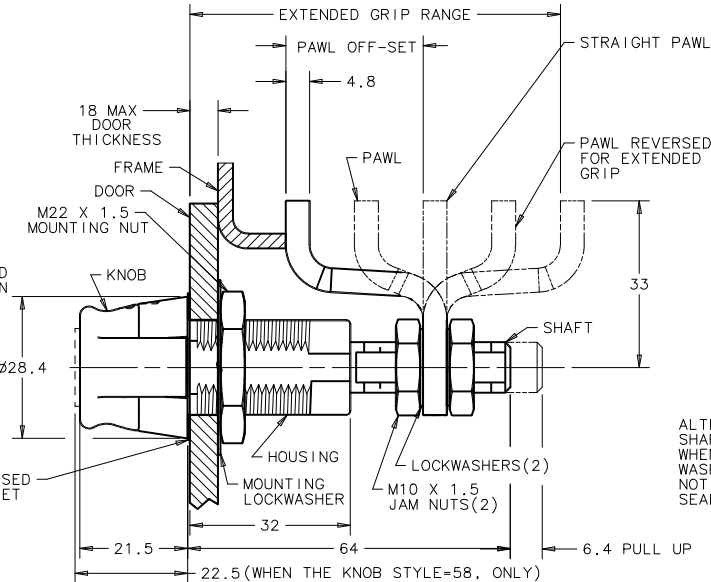
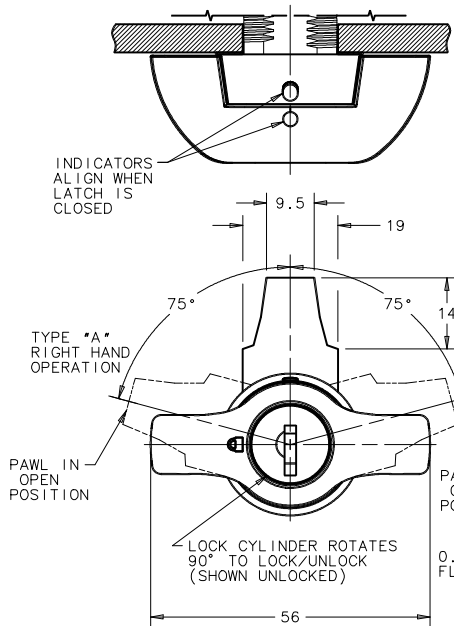

DOOR PREPARATION

METHOD A

METHOD B
 (NOT RECOMMENDED FOR GASKETED APPLICATIONS)

