

NOTES:

- A. OPERATION: 195° TURN OF KEY CAUSES PAWL TO ROTATE 75° THEN PULL UP.
 B. PAWL, NUTS, AND LOCKWASHERS SHIPPED UNASSEMBLED IN BAG WITH LATCH ASSEMBLY.
 C. INSTALLATION:
 1. INSERT LATCH INTO HOLE IN DOOR. CHECK FOR PROPER ORIENTATION AND OPERATION OF PAWL.
 2. INSTALL USING LOCKWASHER AND MOUNTING NUT (27mm ACROSS FLATS). MAX. TIGHTENING TORQUE 28 Nm.
 3. INSTALL JAM NUT, LOCKWASHER, PAWL, LOCKWASHER, AND JAM NUT ON SHAFT. ADJUST JAM NUTS TO POSITION PAWL AT CORRECT GRIP (WITH LATCH CLOSED). TIGHTEN JAM NUTS (20 Nm MAX. TORQUE) USING TWO 17mm WRENCHES.
 4. CAUTION:
 ADJUST PAWL SO THAT NO MORE THAN 7.9Nm TORQUE ON DRIVER IS REQUIRED TO CLOSE LATCH.

X - FINISH TABLE

- 1 - BRIGHT CHROME PLATE
- 4 - CARDINAL WHITE POWDER COAT
- 5 - BLACK POWDER COAT
- 6 - LIGHT GREY POWDER COAT
- 7 - SATIN SILVER POLYESTER POWDER COAT
- 8 - SILVER METALLIC URETHANE POWDER COAT

southco

PROPRIETARY ITEM - EXCEPT FOR USES EXPRESSLY GRANTED IN WRITING INFORMATION DISCLOSED HEREON IS CONFIDENTIAL AND ALL RIGHTS PATENT AND OTHERWISE ARE RESERVED BY SOUTHCO, INC.

**WISE-ACTION LATCH
 BELLCORE ELECTRONICS STYLE**

DATE	DRAWN	CHKD	SCALE	DRAWING NUMBER
10JUN99	SCK	JSS	1:1	J-E3-116

REV	DATE	DRAWN/CHKD	DESCRIPTION	ITEM	PART NUMBER	GRIP RANGE	EXTENDED GRIP RANGE	PAWL OFF-SET
A	14FEB2001	JRS/JSS	PRN: E3-847A	LATCH ASSEMBLY	E3-116-1X	11.4-27.2	66.3 - 76.2	27.4
B	21FEB2003	RLR/MJS	PRN: P2003-0112	LATCH ASSEMBLY	E3-116-2X	25.4-41.1	52.6 - 68.3	13.7
C	01MAY2007	BWR/RLR	PRN: P2007-0587	LATCH ASSEMBLY	E3-116-3X	38.9-54.6	NONE	NONE
D	29JAN2015	CMS/MWD	PRN: P2015-0226					
E	02NOV2017	CMS/CDW	PRN: P2017-2693					

MILLIMETERS
 ALL DIMENSIONS WITHOUT TOLERANCES ARE FOR REFERENCE ONLY.

THE ABOVE PART NUMBERS ARE TYPE "A" (TURN CLOCKWISE TO LATCH); FOR TYPE "B" ASSEMBLIES (TURN COUNTERCLOCKWISE TO LATCH), CHANGE THE THIRD DIGIT OF THE PART NUMBER FROM 1 TO 22. EXAMPLE: E3-2216-15

COMPONENT	MATERIAL	FINISH
HOUSING	DIE CAST ZINC	SEE FINISH TABLE
CAP	DIE CAST ZINC	SEE FINISH TABLE
RETAINER	302 STAINLESS STEEL	NATURAL
SPRING	302 STAINLESS STEEL	NATURAL
O-RING	BUNA-N	NATURAL
SLEEVE	1075 STEEL	ZINC IMMERSION COATING †
CAM	1075 STEEL	ZINC IMMERSION COATING †
SHAFT	LOW CARBON STEEL	ZINC PLATE, CHROMATE PLUS SEALER
PIN	1008 STEEL	ZINC PLATE PLUS CHROMATE DIP, YELLOW
PAWL	1010 STEEL	ZINC PLATE, CHROMATE PLUS SEALER
JAM NUTS (2)	LOW CARBON STEEL	ZINC PLATE, CHROMATE PLUS SEALER
LOCKWASHERS (2)	SPRING STEEL	ZINC ALLOY PLATE BRIGHT CHROMATE, PLUS SEALER
MOUNTING NUT	DIE CAST ZINC	ZINC PLATE, BRIGHT CHROMATE
MOUNTING LOCKWASHER	SPRING STEEL	ZINC ALLOY PLATE BRIGHT CHROMATE, PLUS SEALER

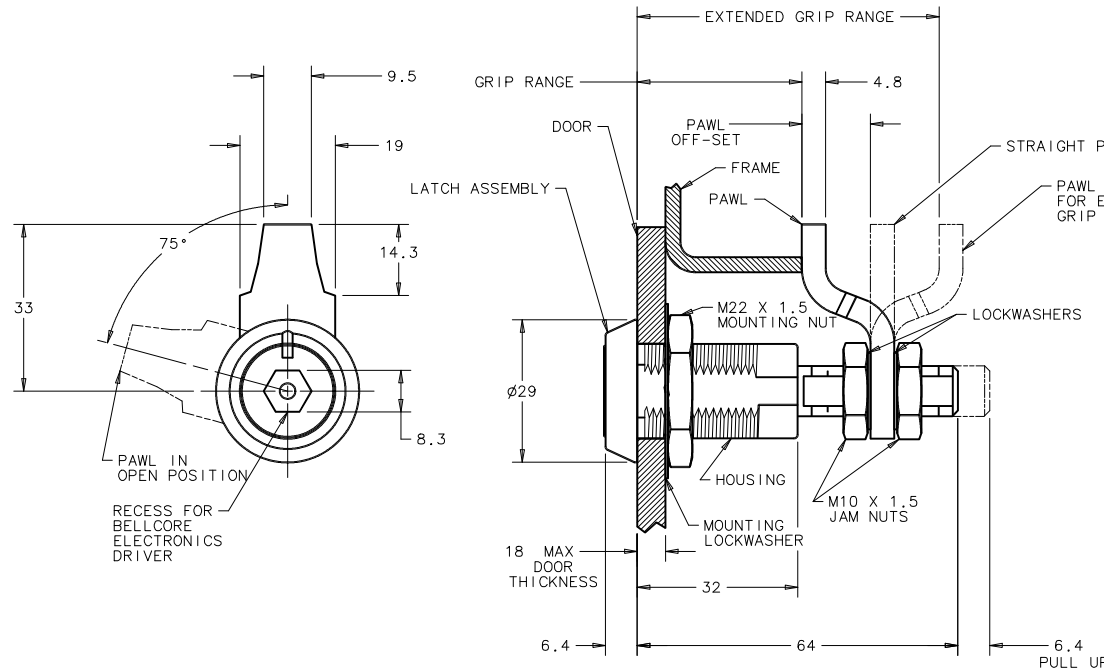

DOOR PREPARATION

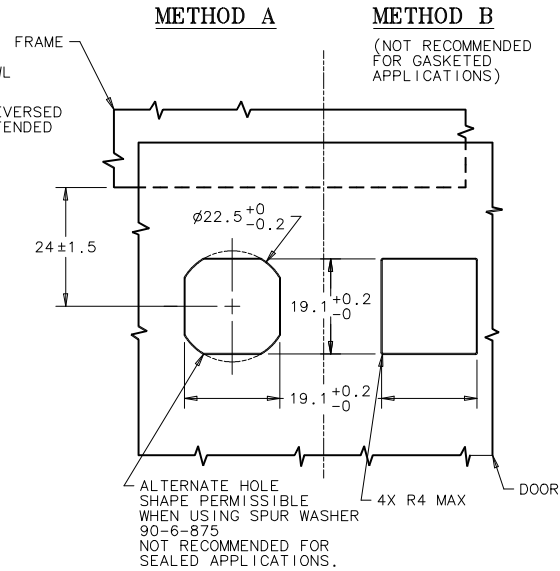

† TM - METAL COATINGS INTERNATIONAL, INC.