

NOTES:

- A. OPERATION: 195° TURN OF HANDLE CAUSES PAWL TO ROTATE 75° THEN PULL UP 0.25.
- B. PAWL, NUTS, AND LOCKWASHERS SHIPPED UNASSEMBLED IN BAG WITH LATCH ASSEMBLY.
- C. INSTALLATION:
  1. INSERT LATCH INTO HOLE IN DOOR. CHECK FOR PROPER ORIENTATION AND OPERATION OF PAWL.
  2. INSTALL USING LOCKWASHER AND MOUNTING NUT (27mm ACROSS FLATS), MAX. TIGHTENING TORQUE 250 in-lb.
  3. INSTALL JAM NUT, LOCKWASHER, PAWL, LOCKWASHER, AND JAM NUT ON SHAFT. ADJUST JAM NUTS TO POSITION PAWL AT CORRECT GRIP (WITH LATCH CLOSED). TIGHTEN JAM NUTS (180 in-lb MAX. TORQUE) USING TWO 17mm WRENCHES.
  4. CAUTION: ADJUST PAWL SO THAT NO MORE THAN 70 in-lb TORQUE ON HANDLE IS REQUIRED TO CLOSE LATCH.

**X FINISH TABLE**

- 1 - BRIGHT CHROME PLATE
- 4 - CARDINAL WHITE POWDER COAT
- 5 - BLACK POWDER COAT
- 6 - LIGHT GREY POWDER COAT
- 7 - SATIN SILVER POLYESTER POWDER COAT
- 8 - SILVER METALLIC URETHANE POWDER COAT

**southco**

PROPRIETARY ITEM - EXCEPT FOR USES EXPRESSLY GRANTED IN WRITING INFORMATION DISCLOSED HEREON IS CONFIDENTIAL AND ALL RIGHTS PATENT AND OTHERWISE ARE RESERVED BY SOUTHCO, INC.

**WISE-ACTION LATCH-INTERNATIONAL SERIES NON-LOCKING T-HANDLE**

DATE	DRAWN	CHKD	SCALE	DRAWING NUMBER
27FEB2003	RES		1:1	J-E3-11

REV	DATE	DRAWN/CHKD	DESCRIPTION	ITEM	PART NUMBER	GRIP RANGE	EXTENDED GRIP RANGE	PAWL OFF-SET
K	27FEB2003	RLR/MJS	PRN: P2003-0112	LATCH ASSEMBLY	E3-11-1X	0.45-1.07	2.61-3.00	1.08
L	01MAY2007	BWR/RLR	PRN: P2007-0587	LATCH ASSEMBLY	E3-11-2X	1.00-1.62	2.07-2.69	0.54
M	28JAN2015	CMS/MWD	PRN: P2015-0219	LATCH ASSEMBLY	E3-11-3X	1.53-2.15	NONE	NONE
				LATCH ASSEMBLY	E3-11-41X	0.13-0.75	2.93-3.50	1.40

**INCHES**

ALL DIMENSIONS WITHOUT TOLERANCES ARE FOR REFERENCE ONLY.



THE ABOVE PART NUMBERS ARE TYPE \*A\* (TURN CLOCKWISE TO LATCH). FOR TYPE \*B\* ASSEMBLIES (TURN COUNTER-CLOCKWISE TO LATCH), CHANGE THE THIRD DIGIT OF THE PART NUMBER FROM 1 TO 22. EXAMPLE: E3-221-15

COMPONENT	MATERIAL	FINISH
HOUSING	DIE CAST ZINC	SEE FINISH TABLE
HANDLE	DIE CAST ZINC	SEE FINISH TABLE
RETAINER	302 STAINLESS STEEL	NATURAL
SPRING	302 STAINLESS STEEL	NATURAL
O-RING	BUNA-N	NATURAL
SLEEVE	1075 STEEL	ZINC IMMERSION COATING †
CAM	1075 STEEL	ZINC IMMERSION COATING †
SHAFT	LOW CARBON STEEL	ZINC PLATE CHROMATE, PLUS SEALER
PIN	1008 STEEL	ZINC PLATE PLUS CHROMATE DIP, YELLOW
PAWL	1010 STEEL	ZINC PLATE CHROMATE, PLUS SEALER
JAM NUTS (2)	LOW CARBON STEEL	ZINC PLATE CHROMATE, PLUS SEALER
LOCKWASHERS (2)	SPRING STEEL	ZINC PLATE CHROMATE, PLUS SEALER
MOUNTING NUT	DIE CAST ZINC	ZINC PLATE, BRIGHT CHROMATE
MOUNTING LOCKWASHER	SPRING STEEL	ZINC PLATE CHROMATE, PLUS SEALER

**DOOR PREPARATION**

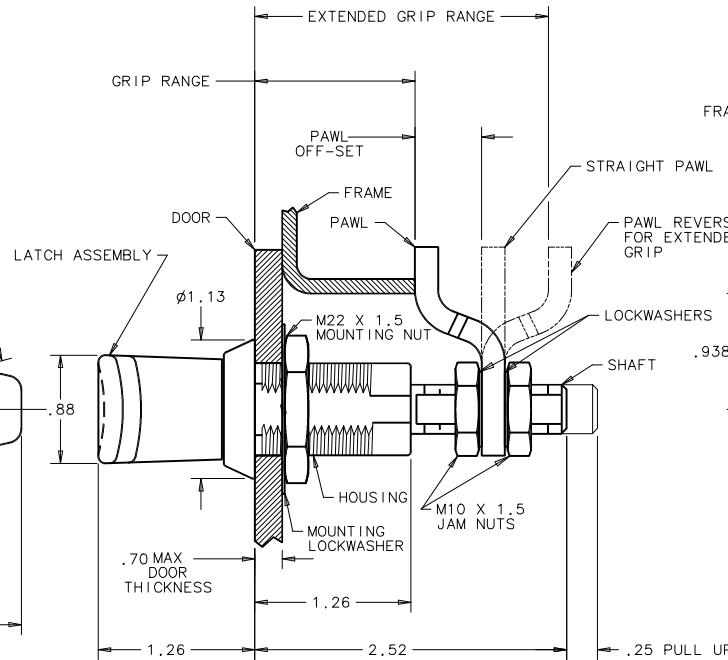
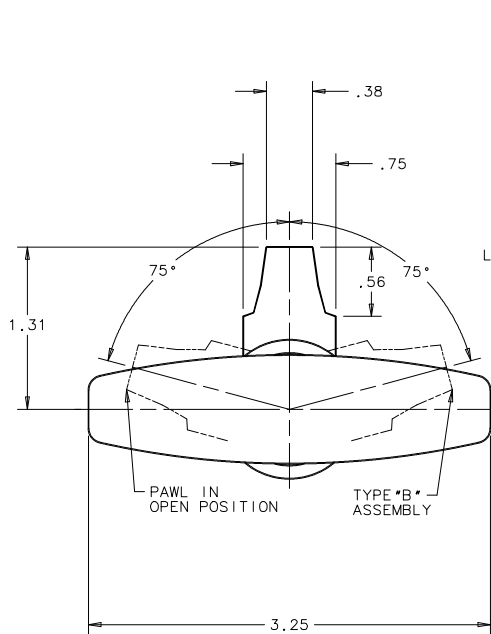

**METHOD A**

**METHOD B**

(NOT RECOMMENDED FOR GASKETED APPLICATIONS)

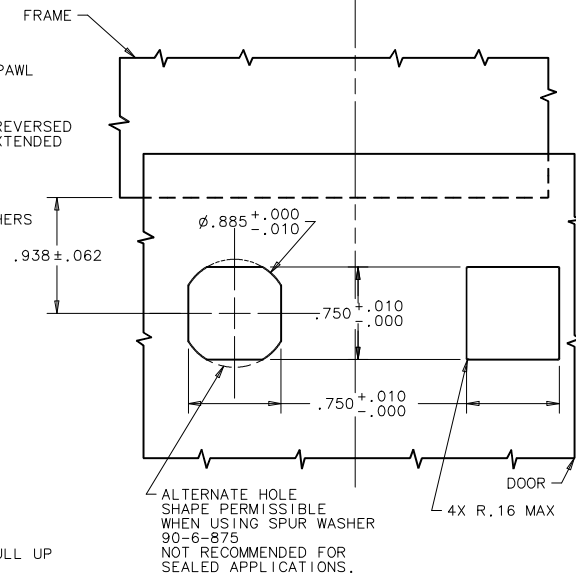

† TM - METAL COATINGS INTERNATIONAL, INC.