

# D8-314-H K-F

REVISION HISTORY			
REV	DATE	BY	DESCRIPTION
G	30MAR2018	SPD/VK	PRN: P2018-0792

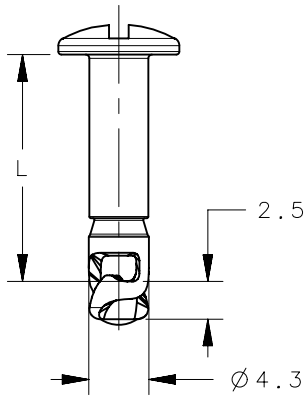

- H-HEAD STYLE OPTIONS
- 1-SLOTTED
  - 2-HEX RECESS
  - 3-WING
  - 30-LONG WING
  - 4-RING
  - 7-PHILLIPS RECESS

- F-FINISH OPTIONS
- 121-SILVER ORGANIC COATING PLUS SEALER
  - 130-SILVER POLYMER COATING PLUS SEALER
  - 131-BLACK POLYMER COATING PLUS SEALER
  - 142-BLACK ORGANIC COATING
  - 170-BRIGHT CHROME
  - 172-BRIGHT CHROME PLUS DOUBLE NICKEL LAYER
  - 190-ZINC PLATE PLUS CLEAR CHROMATE
  - 191-ZINC PLATE PLUS BLACK CHROMATE

K-STUD 'L' DIMENSIONS

K	'L' ±.15
08	8.0
09	9.0
10	10.0
11	11.0
12	12.0
13	13.0
14	14.0
15	15.0
16	16.0
17	17.0
18	18.0
19	19.0
20	20.0
21	21.0
22	22.0
23	23.0
24	24.0
25	25.0
26	26.0
27	27.0
28	28.0
29	29.0
30	30.0
31	31.0
32	32.0
33	33.0
34	34.0
35	35.0
36	36.0
37	37.0
38	38.0

SLOTTED	HEX RECESS	WING	LONG WING	RING HANDLE	NO.2 PHILLIPS RECESS
ORIENTED WITH CAM	NOT ORIENTED WITH CAM	ORIENTED WITH CAM	ORIENTED WITH CAM	ORIENTED WITH CAM	NOT ORIENTED WITH CAM

- NOTES:
1. MATERIAL: CASE HARDENED STEEL.
  2. PANEL PREPARATION  $\phi 5.2/5.0$
  3. SEE DRAWING J-D8-06 FOR ADDITIONAL FINISHES.

<p>THIRD ANGLE PROJECTION</p>	<p><b>southco</b><sup>®</sup></p> <p>CONNECT • CREATE • INNOVATE</p>				
			<p>DESCRIPTION</p> <p>PANEX QUARTER-TURN SIZE 4 STUD</p>		
	<p>TOLERANCES UNLESS OTHERWISE NOTED</p>		<p>SIZE</p> <p>A4</p>		
	<p>ALL DIMENSIONS WITHOUT TOLERANCES ARE FOR REFERENCE ONLY.</p>		<p>SYSTEM</p> <p>NX</p>		
<p>PROPRIETARY ITEM</p> <p>EXCEPT FOR USES EXPRESSLY GRANTED IN WRITING, INFORMATION DISCLOSED HEREON IS CONFIDENTIAL AND ALL RIGHTS, PATENT AND OTHERWISE, ARE RESERVED BY SOUTHCO, INC.</p>	<p>DWG NO.</p> <p>J-D8-314</p>	<p>DATE</p> <p>10DEC2008</p>	<p>SCALE</p> <p>2:1</p>	<p>SHEET</p> <p>1 OF 1</p>	
<p>PER ASME Y14.5M-1994</p>		<p>DRAWN BY</p> <p>MJW</p>	<p>DATE</p> <p>10DEC2008</p>	<p>SCALE</p> <p>2:1</p>	<p>SHEET</p> <p>1 OF 1</p>