

REVISION HISTORY			
REV	DATE	BY	DESCRIPTION
B	23OCT2013	MWC/YGC	PRN: P2013-2095

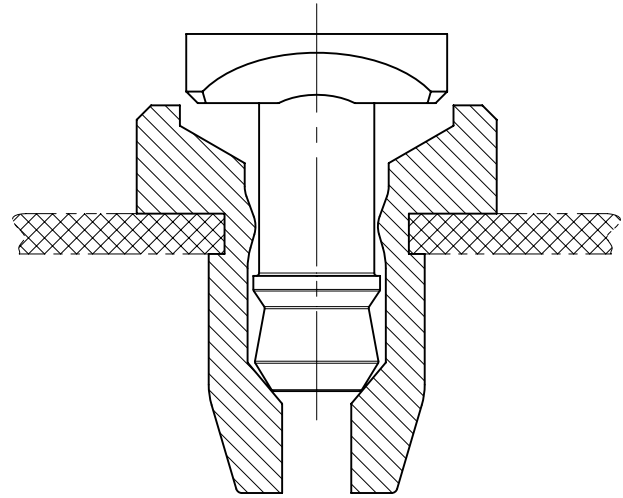
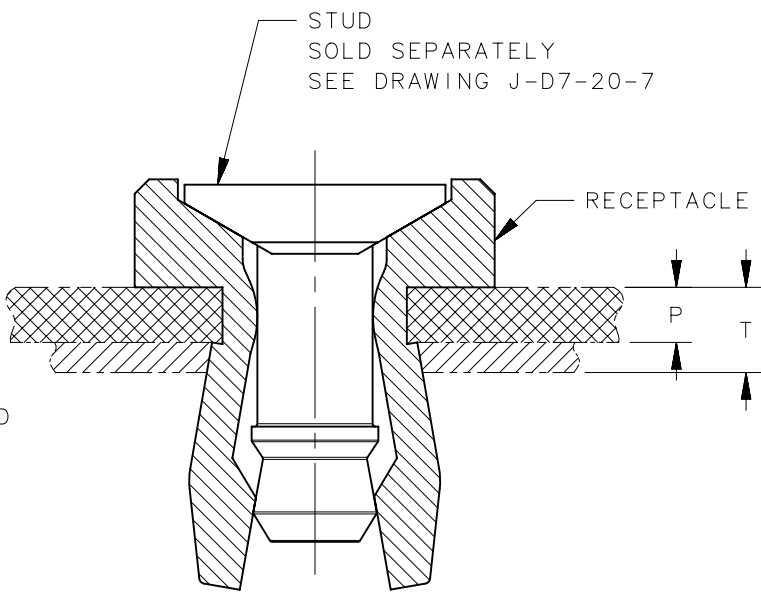
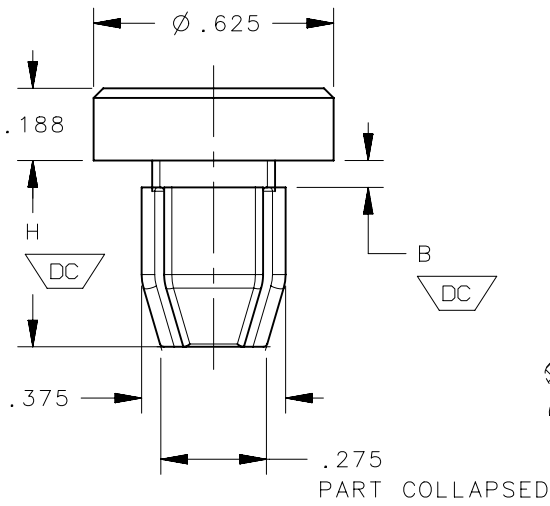

LOCKED

RELEASED

PANEL PREPARATION  
 TOP PANEL : .360 SQ.+.005  
 BOTTOM PANEL : .375 SQ.+.005

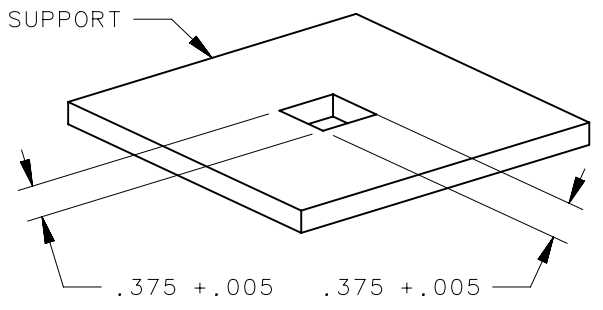
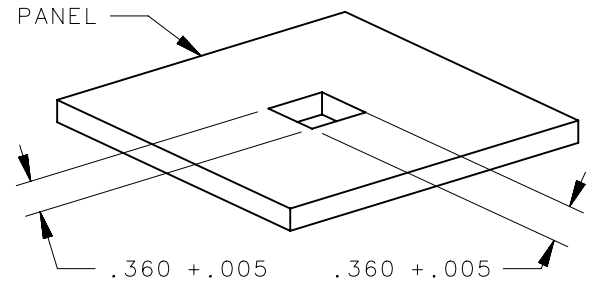

NOTES:  
 1) FOR UV RESISTANT MATERIAL CHANGE SUFFIX -010 TO -030.  
 EXAMPLE PART NUMBER:- D7-200-802-030

D7-201-802-010	ACETAL	BLACK	.070-.124	.135-.250	.125	.54
D7-200-802-010	ACETAL	BLACK	.020-.069	.080-.200	.070	.48
PART NUMBER	MATERIAL	COLOR	P PANEL THICKNESS	T PANEL PLUS SUPPORT	B RECEPTACLE UNDERCUT	H LENGTH UNDER HEAD

THIRD ANGLE PROJECTION	
INCHES [MM]	
TOLERANCES UNLESS OTHERWISE NOTED	
ALL DIMENSIONS WITHOUT TOLERANCES ARE FOR REFERENCE ONLY.	
PER ASME Y14.5M-1994	

**southco**<sup>®</sup>  
 CONNECT • CREATE • INNOVATE

DESCRIPTION  
 ARROW QUARTER  
 TURN RECEPTACLE

SIZE A SYSTEM NX DWG NO. J-D7-20-802

DRAWN BY ALI DATE 12AUG2006 SCALE NTS SHEET 1 OF 1

PROPRIETARY ITEM  
 EXCEPT FOR USES EXPRESSLY GRANTED  
 IN WRITING, INFORMATION DISCLOSED  
 HEREON IS CONFIDENTIAL AND ALL  
 RIGHTS, PATENT AND OTHERWISE,  
 ARE RESERVED BY SOUTHCO, INC.