



D7 DZUS® Pilot Quarter-Turn Fasteners Studs

Material and Finish

Studs: Steel, zinc plated plus chromate

Washer: Neoprene, black

Notes

Select stud and washer part number from table based on your panel thickness **P**

Part Number

See table

Order stud and washer separately

Studs

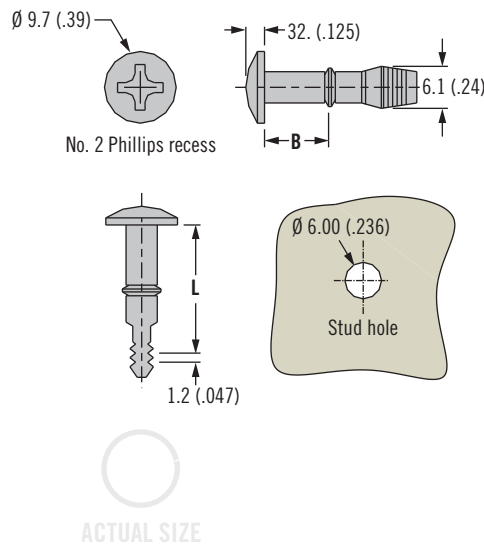

Washer

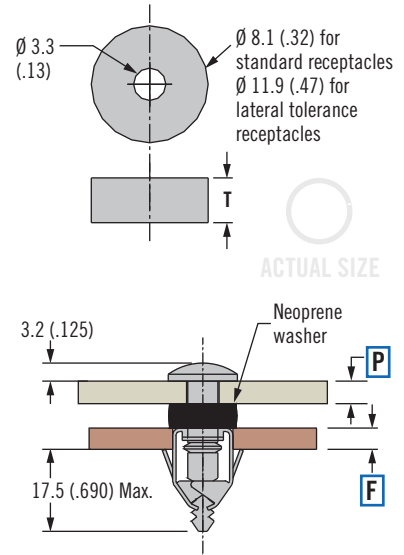

Panel Thickness P	Stud L	Stud B	T Washer Thickness	Part Number			
				Stud		Neoprene Washer	
				Black chromate	Bright chromate	For standard receptacle	For lateral tolerance receptacle
1.3 (.05) to 1.7 (.07)	16 (.63)	7.1 (.28)	4.1 (.16)	D7-265-716-191	D7-265-716-190	D7-275-040-400	D7-275-140-400
1.8 (.07) to 2.2 (.09)	16 (.63)	7.1 (.28)	3.6 (.14)	D7-265-716-191	D7-265-716-190	D7-275-035-400	D7-275-135-400
2.3 (.09) to 2.7 (.11)	17.8 (.70)	8.9 (.35)	5.1 (.20)	D7-265-718-191	D7-265-718-190	D7-275-050-400	D7-275-150-400
2.8 (.11) to 3.2 (.12)	17.8 (.70)	8.9 (.35)	4.6 (.18)	D7-265-718-191	D7-265-718-190	D7-275-045-400	D7-275-145-400
3.3 (.13) to 3.7 (.15)	17.8 (.70)	8.9 (.35)	4.1 (.16)	D7-265-718-191	D7-265-718-190	D7-275-040-400	D7-275-140-400
3.8 (.15) to 4.2 (.17)	17.8 (.70)	8.9 (.35)	3.6 (.14)	D7-265-718-191	D7-265-718-190	D7-275-035-400	D7-275-135-400
4.3 (.17) to 4.8 (.19)	20.0 (.79)	10.9 (.43)	5.1 (.20)	D7-265-720-191	D7-265-720-190	D7-275-050-400	D7-275-150-400

Material and Finish

Steel, zinc plated and thermoplastic black

Notes

Select stud and washer part number from table based on your panel thickness **P**

Part Number

See table

Stud, cup and spring shipped pre-assembled

Order retainer separately

Self-Ejecting Studs

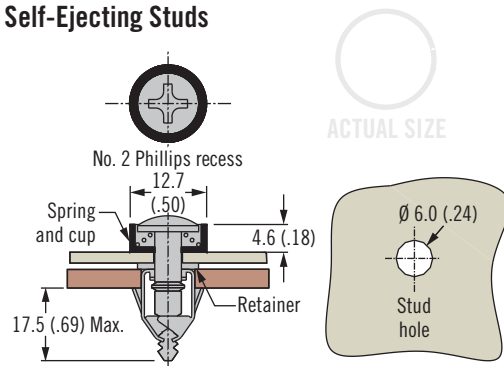

Panel Thickness P	Part Number	
	Black	Bright
0.5 - 3.0 (.02 - .12)	D7-290-718-191	D7-290-718-190
2.5 - 5.1 (.10 - .20)	D7-290-720-191	D7-290-720-190

Retainer, Plastic

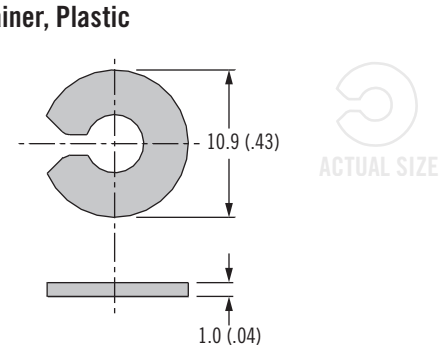

Part Number
D7-275-203-040

D7 DZUS® Pilot Quarter-Turn Fasteners Receptacles

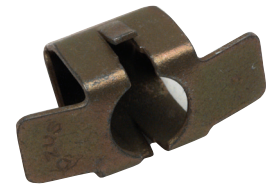

Standard

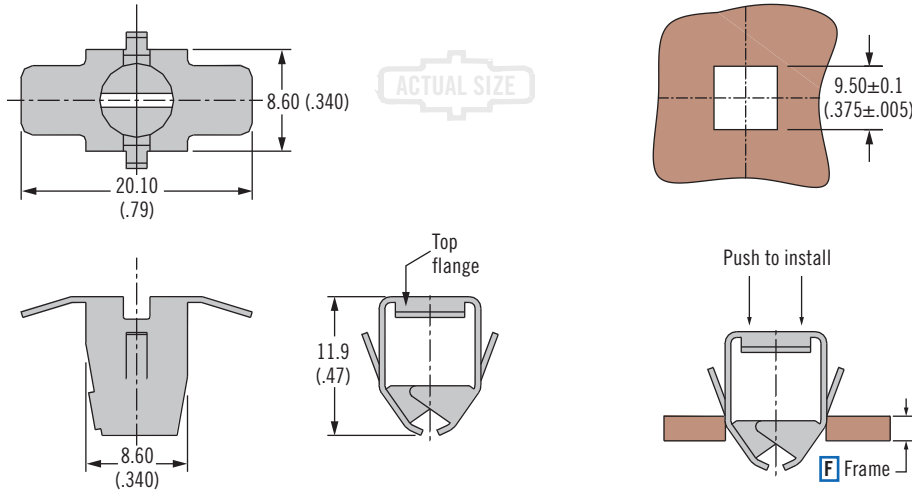

F Frame Thickness		Part Number
Min.	Max.	
0.63 (.025)	1.24 (.049)	D7-285-101-161
1.27 (.050)	1.75 (.069)	D7-285-102-161
1.78 (.070)	2.26 (.089)	D7-285-103-161

Material and Finish

Spring steel, zinc phosphate

Notes

Select receptacle based on frame thickness **F**

82

85

D8

D9

D1

D4

D5

D7

NY



Part Number

See table

Lateral Tolerance

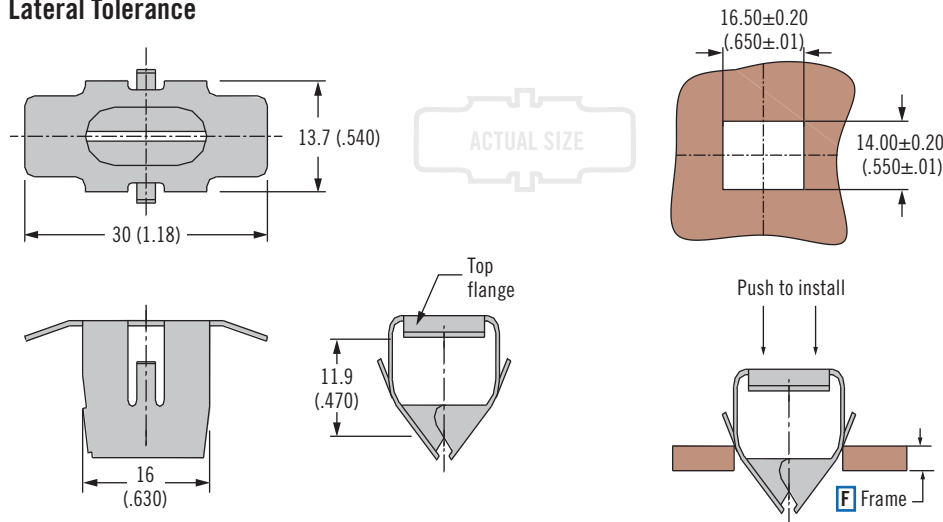

F Frame Thickness		Part Number
Min.	Max.	
0.63 (.025)	1.24 (.049)	D7-285-201-161
1.27 (.050)	1.75 (.069)	D7-285-202-161
1.78 (.070)	2.26 (.089)	D7-285-203-161
2.29 (.090)	2.77 (.109)	D7-285-204-161
2.79 (.110)	3.28 (.129)	D7-285-205-161

Material and Finish

Spring steel, zinc phosphate

Notes

Select receptacle based on frame thickness **F**

Part Number

See table



D7 DZUS® Arrow Quarter-Turn Fasteners Assembly

- Surface install
- Panel mounted assembly

Material and Finish

Acetal, black

Performance Details

Flammability rating: UL94-HB

ASTM E-162 Flame spread Index:

130

D7 Arrow Installation notes

200 series:

1. Press receptacle into outer panel.
2. Press stud into receptacle.
3. Press and turn stud to latch.
4. Turn stud 90 degree to unlatch.

2001 series:

1. Separate Stud and receptacle from runner.
2. Press receptacle into outer panel.
3. Press stud into receptacle.
4. Press and turn stud to latch.
5. Turn stud 90 degree to unlatch.

Part Number

See table

200 Series: Order one receptacle and stud from the same size separately

2001 Series: Complete assembly supplied with runner attached as shown

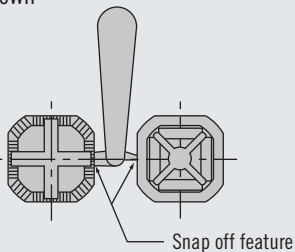

200 Series (order stud and receptacle separately)

Locked

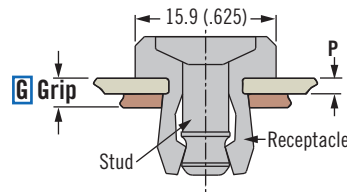

Released

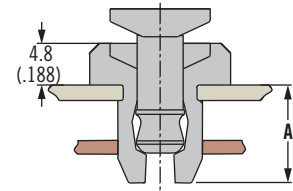

Hex Recess

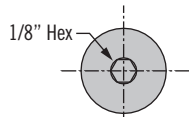

Slotted

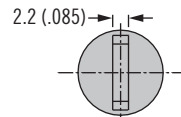

Knob

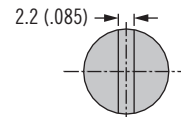

2001 Series

Latched

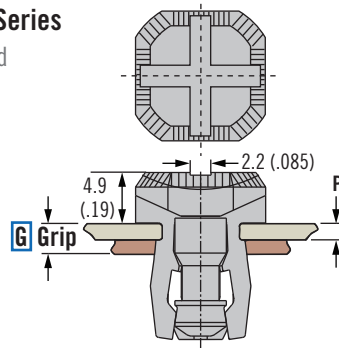

Unlatched

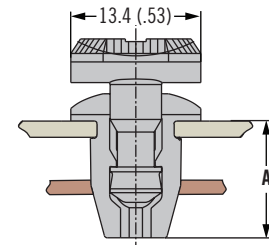

Installation

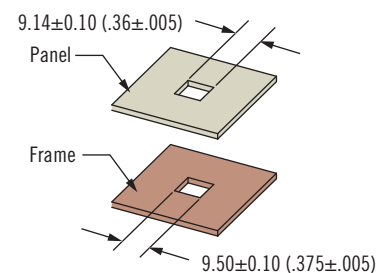
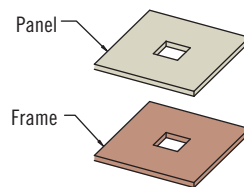

Series	A	Receptacle			Stud				
		Panel Thickness		Part Number	Grip Range		Part Number		
		Min.	Max.		Min.	Max.	Hex recess	Slotted recess	Knob
200	12.3 (.48)	0.50 (.020)	1.78 (.070)	D7-200-802-010	2.03 (.080)	5.08 (.200)	D7-200-701-010	D7-200-711-010	D7-200-721-010
	13.7 (.54)	1.80 (.071)	3.10 (.125)	D7-201-802-010	3.43 (.135)	6.35 (.250)	D7-201-701-010	D7-201-711-010	D7-201-721-010
2001	12.0 (.47)	Complete Assembly			2.5 (.098)	6.7 (.263)	D7-2001-010		

Dimensions in millimeters (inch) unless otherwise stated

Installation Guidelines

for *SOUTHCO*® Self-Clinching products

Self-clinching product installation is offered on these *SOUTHCO*® products, making them easy-to-use captive panel fasteners:

- Captive Screws
- Receptacles for Quarter-turn Fasteners
- Receptacles for Fast-lead Thread Screws

When pressed into a properly prepared hole, self-clinching captive fasteners cold-flow (move) the panel material into the retaining groove of the fastener. This material then retains the fastener in the panel.

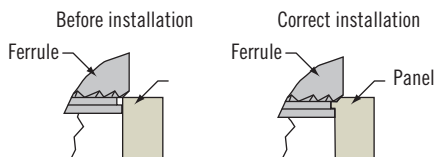

Successful press-in installations depend on:

Material:

The hardness of the panel material must not exceed *SOUTHCO*® recommendations. If the panel is too hard, the fastener will not install correctly.

Installation Holes:

Mounting holes may be drilled, punched, or cast.

- Hole edge: the top hole edge must be sharp but with no broken edges.

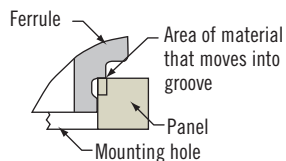

Do not chamfer or debur edge.

- Punched holes: use a punch and die with a small clearance to minimize the rollover and fracture angle.
- Hole diameter: measure the hole diameter at the panel surface on the side on which the fastener will be installed. The diameter must be within *SOUTHCO*® specifications for that product.

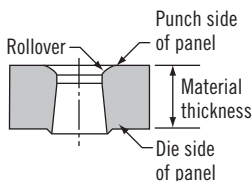

- If the hole is too large, not enough material will flow into the

retaining groove and the fastener may not be retained adequately.

- If the hole is too small, the fastener will not fit and installation may become difficult and unsafe.
- Hole distance from the edge of panel: the minimum recommended distance is 1.5 x the diameter of the mounting hole, unless otherwise indicated.

- Spring-loaded Plungers
- Captive Nuts
- Threaded Inserts

- Installing too close to the edge will cause the material to flow in the opposite direction, deforming the edge of the panel. To install closer to the edge, you may need to restrain the panel edge.

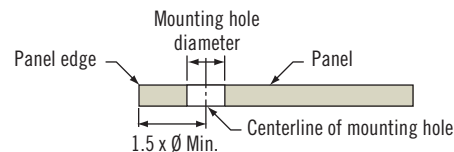

Panel Thickness:

The thickness of the panel at the mounting hole location must meet or exceed Southco's stated minimum recommendations.

If the material is too thin, panel deformation and/or damage to the fastener may result.

Installation is fast and easy if you follow these tips:

How to install: Use the recommended force where noted and a proper back-up tool.

- use any parallel-acting press
- use a punch whose diameter is larger than the head of the fastener

Installation Force: Proper installation requires an even distribution of adequate force. It does not depend on the distance the fastener is pressed into the panel.

- Southco does not recommend using a hammer. The impact force does not provide an even distribution of force to allow the panel material to completely flow into the fastener's retaining groove.
- Installation force varies from application to application, depending on the criteria noted above.
- On parts without a collar to provide a hard stop, press-in until the edge of the knurl is just barely visible.

When to Install:

Installation is recommended after plating or finishing has been applied to the panel.

The hole diameter must meet specifications before finish or plating is applied.

- Do not over-install parts. This interrupts the material and will reduce the retention strength.

