

REVISION HISTORY			
REV	DATE	BY	DESCRIPTION
B	27MAR2017	CMS/JW	PRN: P2017-0679

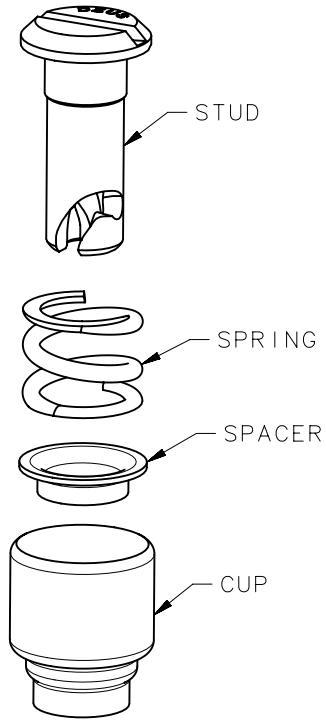

SCALE 2:1

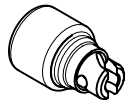
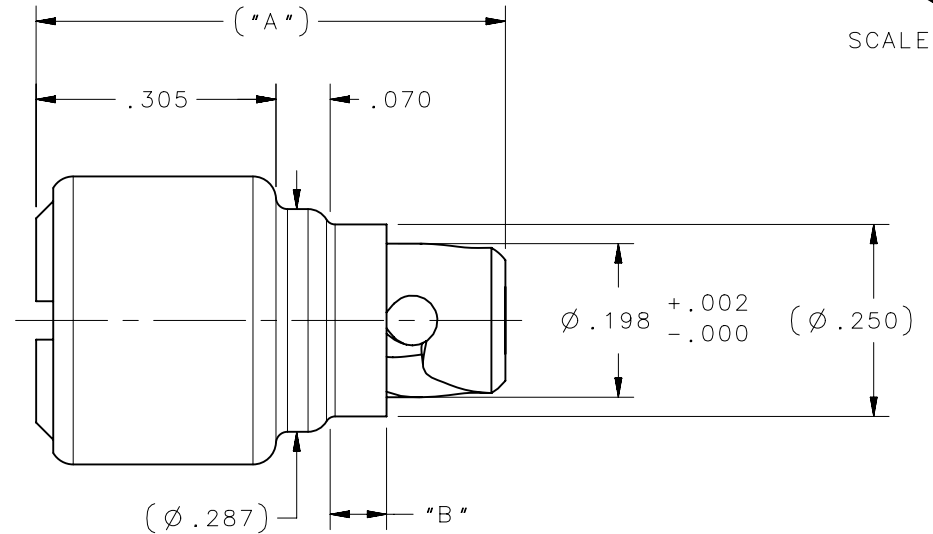
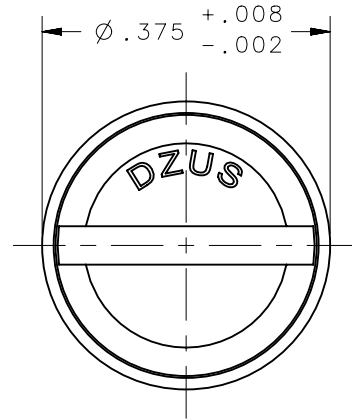

SCALE 1:1

NOTES:

- A. REMOVE ALL BURRS AND BREAK SHARP EDGES.
- B. ALL CORNERS AND FILLETS R.005 MAX.
- C. MATERIAL
 STUD: 4037 OR 8620 STEEL, HEAT TREAT ROCKWELL C31-38
 CUP: 6061 ALUMINUM
 SPRING: MUSIC WIRE PER ASTM-A228
 SPACER: 1095 STEEL, HEAT TREAT ROCKWELL C45-50.
- D. FINISH:
 PLEASE REFER TO J-D5-0-3 FOR FINISH INFORMATION AND SPECIFICATIONS.

3500-325-45-Z3B	D5-P325-45ZBBNA	0.61	0.078
3500-325-45-AS1B	D5-P325-45ASBNA	0.61	0.078
3500-325-45-EEB	D5-P325-45SEBNA	0.61	0.078
3500-325-45-EEG	D5-P325-45SEGNA	0.61	0.078
3500-325-45-EEMB	D5-P325-45SEMBNA	0.61	0.078
3500-325-45-EEMBT	D5-P325-45BTNA	0.61	0.078
3500-325-51-AS1B	D5-P325-51ASBNA	0.67	0.136
3500-325-51-EEG	D5-P325-51SEGNA	0.67	0.136
DFCI PART NUMBER	SOUTHCO PART NUMBER	DIMENSION "A"	DIMENSION "B"

THIRD ANGLE PROJECTION		 CONNECT • CREATE • INNOVATE	
INCHES [MM]			
TOLERANCES UNLESS OTHERWISE NOTED		DESCRIPTION PANEL LINE FASTENER	
ALL DIMENSIONS WITHOUT TOLERANCES ARE FOR REFERENCE ONLY.		SIZE A	SYSTEM NX
PROPRIETARY ITEM <small>EXCEPT FOR USES EXPRESSLY GRANTED IN WRITING, INFORMATION DISCLOSED HEREON IS CONFIDENTIAL AND ALL RIGHTS, PATENT AND OTHERWISE, ARE RESERVED BY SOUTHCO, INC.</small>		DWG NO. J-D5-P325NA	
PER ASME Y14.5M-1994		DRAWN BY CMS/NJF	DATE 09JUL2015
		SCALE 4:1	SHEET 1 OF 1