

REVISION HISTORY			
REV	DATE	BY	DESCRIPTION
B	04SEP2013	JAJ/YGC	PRN: P2013-1775

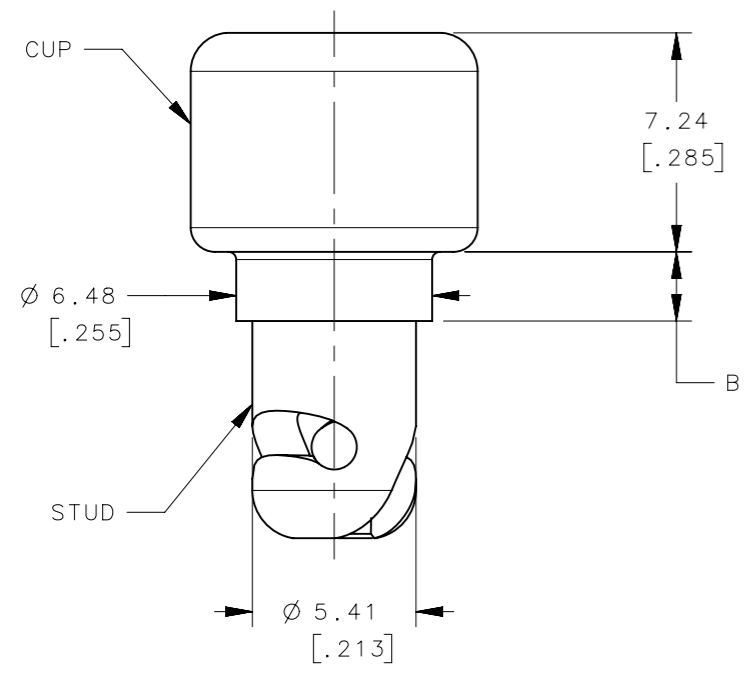

PART No. D5-PFSC35-43A-190 SHOWN

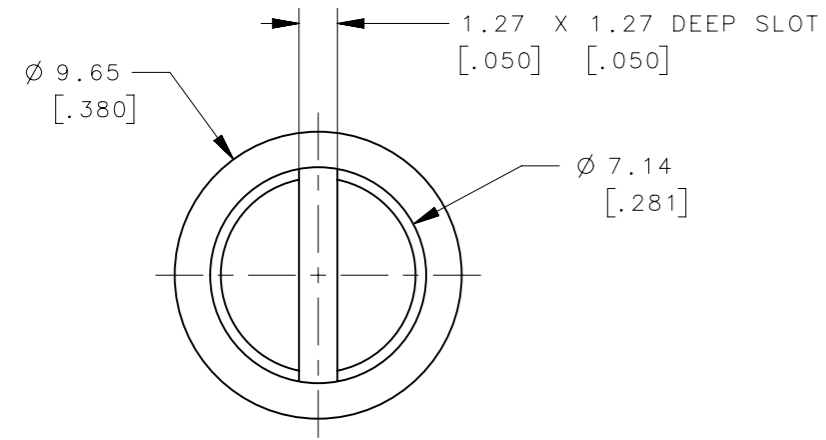
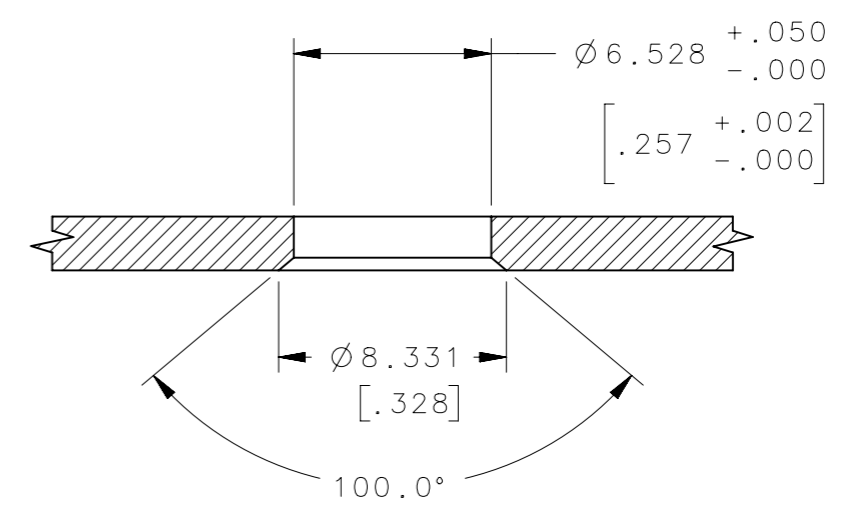
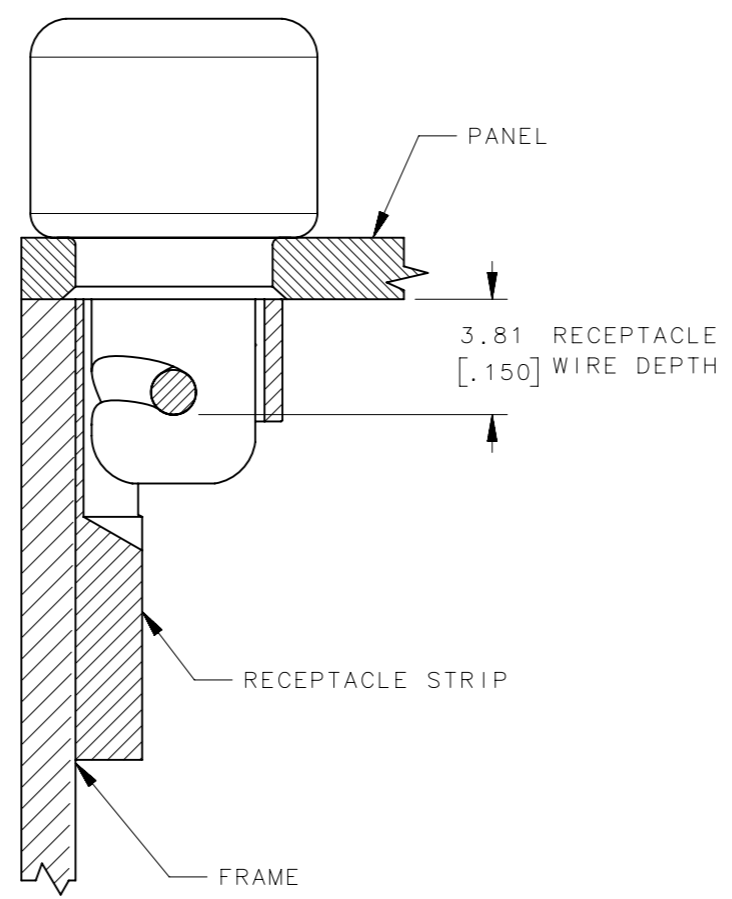

PANEL PREPARATION

INSTALLATION:

1. FLARE THE END OF THE CUP NECK INTO A COUNTERSUNK PANEL HOLE AS SHOWN
2. TURN STUD TO LOCK INTO RECEPTACLE

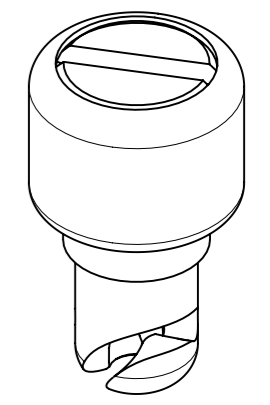

“YYY” FINISH (EXAMPLE PART NUMBER: D5-PFSC35-37A-190)
190 - BRIGHT ZINC PLATE

D5-PFSC35-37A-YYY	1.27(.050)-1.50(.059)	1.78 (.070)
D5-PFSC35-38A-YYY	1.52(.060)-1.75(.069)	2.03 (.080)
D5-PFSC35-39A-YYY	1.78(.070)-2.00(.079)	2.29 (.090)
D5-PFSC35-40A-YYY	2.03(.080)-2.26(.089)	2.54 (.100)
D5-PFSC35-41A-YYY	2.29(.090)-2.51(.099)	2.80 (.110)
D5-PFSC35-42A-YYY	2.54(.100)-2.77(.109)	3.05 (.120)
D5-PFSC35-43A-YYY	2.79(.110)-3.02(.119)	3.30 (.130)
D5-PFSC35-44A-YYY	3.05(.120)-3.28(.129)	3.56 (.140)
PART NUMBER	PANEL THICKNESS	B

NOTES

1. MATERIAL:
STUD: HEAT TREATED CARBON STEEL
CUP: STEEL
SPRING: SPRING TEMPER MUSIC WIRE

THIRD ANGLE PROJECTION						
MILLIMETERS [IN]	DESCRIPTION			D5 STUD ASSEMBLY		
TOLERANCES UNLESS OTHERWISE NOTED	SIZE	SYSTEM	DWG NO.	J-D5-PFSC35-YYY		
ALL DIMENSIONS WITHOUT TOLERANCES ARE FOR REFERENCE ONLY.	A3	NX	DATE	SCALE	SHEET	
PER ASME Y14.5M-1994	MWC/YGC	18JUNE2013	4:1	1 OF 1		
<small>PROPRIETARY ITEM EXCEPT FOR USES EXPRESSLY GRANTED IN WRITING, INFORMATION DISCLOSED HEREON IS CONFIDENTIAL AND ALL RIGHTS, PATENT AND OTHERWISE, ARE RESERVED BY SOUTHCO, INC.</small>						