



D8 DZUS® PANEX Quarter-Turn Fasteners

Studs · Size 4

Material and Finish

Studs: Steel, zinc plated plus chromate or chrome plated
Bail cover: ABS, black

82

85

D8

D9

D1

D4

D5

D7

NY



Installation Notes

Bail cover:

A Retainer must be fitted under the stud head to fit flush with surface

Retainer part number

D8-324-100-040 (see page 397)

H Head Styles - Tool Actuated

Oval Slot

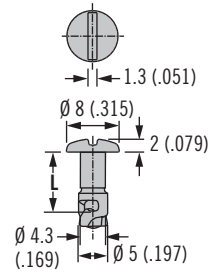

ACTUAL SIZE

Hex Recess

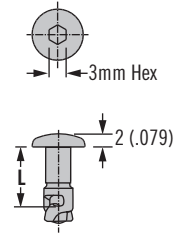

Phillips Recess

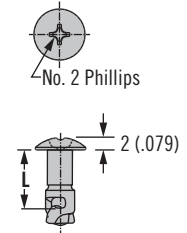

H Head Styles - Hand Actuated

Wing

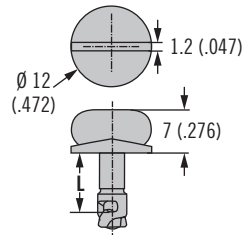

ACTUAL SIZE

Bail

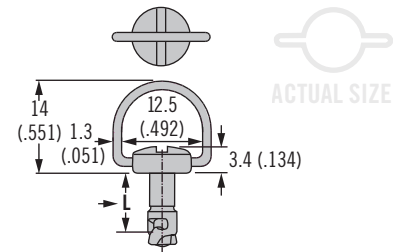

ACTUAL SIZE

Optional Bail Cover

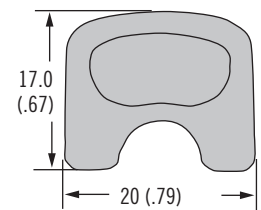
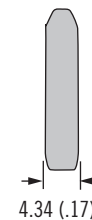
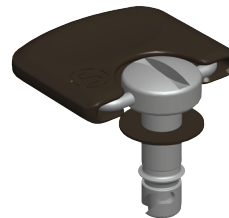

Bail Cover Part Number

D8-4-B-000

Stud Panel Preparation

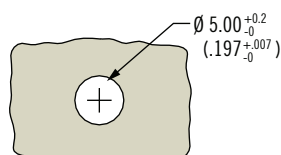

Dimensions in millimeters (inch) unless otherwise stated



www.southco.com/D8

DZUS®

southco®
CONNECT · CREATE · INNOVATE

D8 DZUS® PANEX Quarter-Turn Fasteners

Stud selection · Size 4



Part Number Selection

H Head style

- 1 Slot recess
- 2 Hex recess
- 3 Wing
- 4 Bail
- 7 Phillips recess

K Length

Enter number from selection table below

D8 - 314 - H K - F

F Finish

- 170 Chrome plated
- 190 Zinc plated
- 191 Zinc plated, black

Stud Length Table

A		B		C		D		E		K	L ±.15 ±(.006)
TMT Range For: D8-334-400-121 D8-334-500-121		TMT Range For: D8-334-300-121 D8-334-310-121		TMT Range For: D8-334-200-190		TMT Range For: D8-334-100-300		TMT Range For: D8-334-110-190			
Min.	Max.	Min.	Max.	Min.	Max.	Min.	Max.	Min.	Max.		
1.0 (.04)	1.9 (.07)	1.5 (.06)	2.4 (.09)	~	~	~	~	~	~	08	8 (.315)
2.0 (.08)	2.9 (.11)	2.5 (.10)	3.4 (.13)	~	~	~	~	~	~	09	9 (.354)
3.0 (.12)	3.9 (.15)	3.5 (.14)	4.4 (.17)	~	~	0.7 (.03)	1.6 (.06)	1.7 (.07)	2.6 (.10)	10	10 (.394)
4.0 (.16)	4.9 (.19)	4.5 (.18)	5.4 (.21)	~	~	1.7 (.07)	2.6 (.10)	2.7 (.11)	3.6 (.14)	11	11 (.433)
5.0 (.20)	5.9 (.23)	5.5 (.22)	6.4 (.25)	1.5 (.06)	2.4 (.09)	2.7 (.11)	3.6 (.14)	3.7 (.15)	4.6 (.18)	12	12 (.472)
6.0 (.24)	6.9 (.27)	6.5 (.26)	7.4 (.29)	2.5 (.10)	3.4 (.13)	3.7 (.15)	4.6 (.18)	4.7 (.19)	5.6 (.22)	13	13 (.512)
7.0 (.28)	7.9 (.31)	7.5 (.30)	8.4 (.33)	3.5 (.14)	4.4 (.17)	4.7 (.19)	5.6 (.22)	5.7 (.22)	6.6 (.26)	14	14 (.551)
8.0 (.31)	8.9 (.35)	8.5 (.33)	9.4 (.37)	4.5 (.18)	5.4 (.21)	5.7 (.22)	6.6 (.26)	6.7 (.26)	7.6 (.30)	15	15 (.591)
9.0 (.35)	9.9 (.39)	9.5 (.37)	10.4 (.41)	5.5 (.22)	6.4 (.25)	6.7 (.26)	7.6 (.30)	7.7 (.30)	8.6 (.34)	16	16 (.630)
10.0 (.39)	10.9 (.43)	10.5 (.41)	11.4 (.45)	6.5 (.26)	7.4 (.29)	7.7 (.30)	8.6 (.34)	8.7 (.34)	9.6 (.38)	17	17 (.669)
11.0 (.43)	11.9 (.47)	11.5 (.45)	12.4 (.49)	7.5 (.30)	8.4 (.33)	8.7 (.34)	9.6 (.38)	9.7 (.38)	10.6 (.42)	18	18 (.709)
12.0 (.47)	12.9 (.51)	12.5 (.49)	13.4 (.53)	8.5 (.33)	9.4 (.37)	9.7 (.38)	10.6 (.42)	10.7 (.42)	11.6 (.46)	19	19 (.748)
13.0 (.51)	13.9 (.55)	13.5 (.53)	14.4 (.57)	9.5 (.37)	10.4 (.41)	10.7 (.42)	11.6 (.46)	11.7 (.46)	12.6 (.50)	20	20 (.787)
14.0 (.55)	14.9 (.59)	14.5 (.57)	15.4 (.61)	10.5 (.41)	11.4 (.45)	11.7 (.46)	12.6 (.50)	12.7 (.50)	13.6 (.54)	21	21 (.827)
15.0 (.59)	15.9 (.63)	15.5 (.61)	16.4 (.65)	11.5 (.45)	12.4 (.49)	12.7 (.50)	13.6 (.54)	13.7 (.54)	14.6 (.57)	22	22 (.866)
16.0 (.63)	16.9 (.67)	16.5 (.65)	17.4 (.69)	12.5 (.49)	13.4 (.53)	13.7 (.54)	14.6 (.57)	14.7 (.58)	15.6 (.61)	23	23 (.906)
17.0 (.67)	17.9 (.70)	17.5 (.69)	18.4 (.72)	13.5 (.53)	14.4 (.57)	14.7 (.58)	15.6 (.61)	15.7 (.62)	16.6 (.65)	24	24 (.945)
18.0 (.71)	18.9 (.74)	18.5 (.73)	19.4 (.76)	14.5 (.57)	15.4 (.61)	15.7 (.62)	16.6 (.65)	16.7 (.66)	17.6 (.69)	25	25 (.984)
19.0 (.75)	19.9 (.78)	19.5 (.77)	20.4 (.80)	15.5 (.61)	16.4 (.65)	16.7 (.66)	17.6 (.69)	17.7 (.70)	18.6 (.73)	26	26 (1.02)
20.0 (.79)	20.9 (.82)	20.5 (.81)	21.4 (.84)	16.5 (.65)	17.4 (.69)	17.7 (.70)	18.6 (.73)	18.7 (.74)	19.6 (.77)	27	27 (1.06)
21.0 (.83)	21.9 (.86)	21.5 (.85)	22.4 (.88)	17.5 (.69)	18.4 (.72)	18.7 (.74)	19.6 (.77)	19.7 (.78)	20.6 (.81)	28	28 (1.10)
22.0 (.87)	22.9 (.90)	22.5 (.89)	23.4 (.92)	18.5 (.73)	19.4 (.76)	19.7 (.78)	20.6 (.81)	20.7 (.81)	21.6 (.85)	29	29 (1.14)
23.0 (.91)	23.9 (.94)	23.5 (.93)	24.4 (.96)	19.5 (.77)	20.4 (.80)	20.7 (.81)	21.6 (.85)	21.7 (.85)	22.6 (.89)	30	30 (1.18)

To select correct fastener:

1. Select receptacle

Choose a receptacle from pages 394-396

2. Select retainer and accessories

from page 397 and note any adjustment values

3. Specify stud length

Calculate the total material thickness (TMT) using the formula given for the receptacle selected. Find the range of TMT using the length selection table (left) using the column (A, B, C, D or E) given for the receptacle selected.

4. Complete the stud part number

by specifying the head style **H**, stud length **K**, and material **M**

Example:

For rivet-on

D8-334-400-121 use column A
For TMT value calculated as 5.2 (.206), K = 12

For slotted head style in steel, zinc plated material, completed part number: D8-314-112-190

A complete example can be found on page 377.



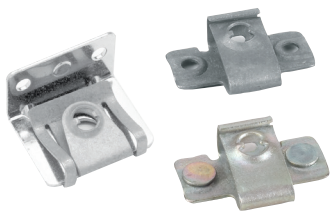

D8 DZUS® PANEX Quarter-Turn Fasteners

Receptacles · Size 4

Material and Finish

Steel, zinc immersion coating

Installation Notes

Install with $\varnothing 3$ (.125) rivets

Part Number

See table

Notes

Utilize stud selection column indicated when choosing a stud length from the stud length table on page 393

Rivet-On

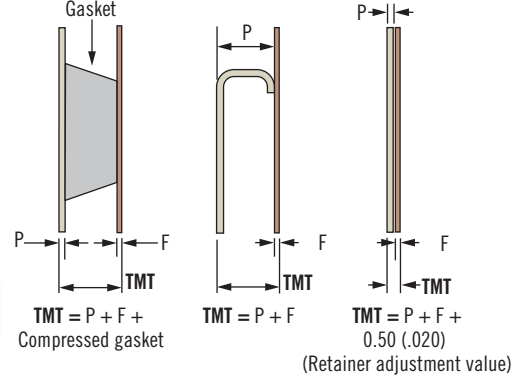
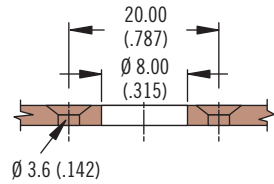
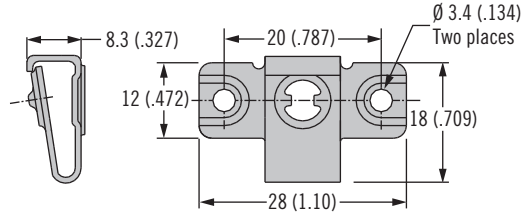

Part Number	Stud Selection Column
D8-334-400-121	A

Material and Finish

Steel, zinc immersion coating

Part Number

See table

Notes

Utilize stud selection column indicated when choosing a stud length from the stud length table on page 393

Weld-On

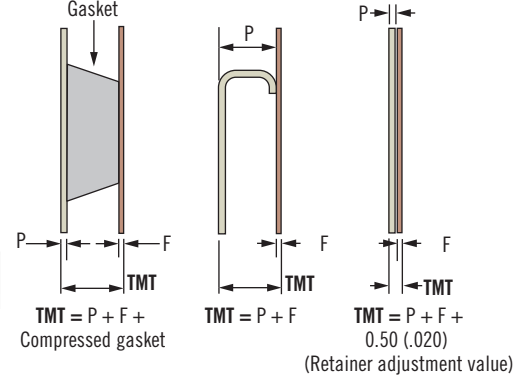
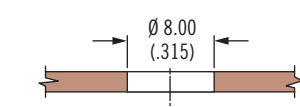
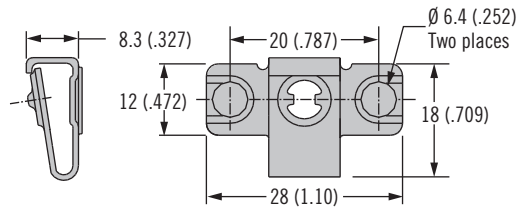

Part Number	Stud Selection Column
D8-334-500-121	A

Material and Finish

Steel, zinc immersion coating

Part Number

See table

Notes

Utilize stud selection column indicated when choosing a stud length from the stud length table on page 393

Side Mount

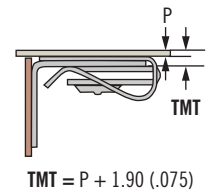
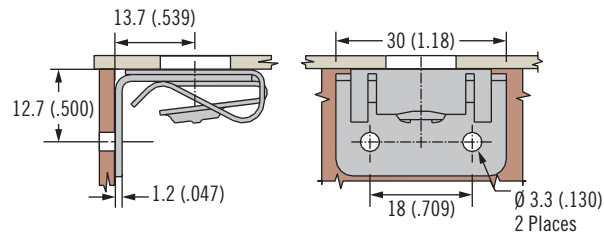

Part Number	Stud Selection Column
D8-334-310-121	B



D8 DZUS® PANEX Quarter-Turn Fasteners

Receptacles · Size 4

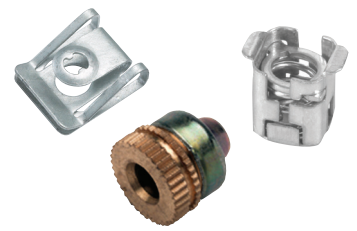

395

Clip-On

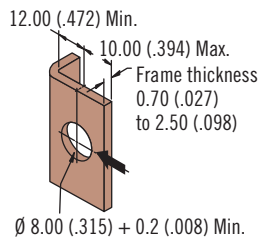
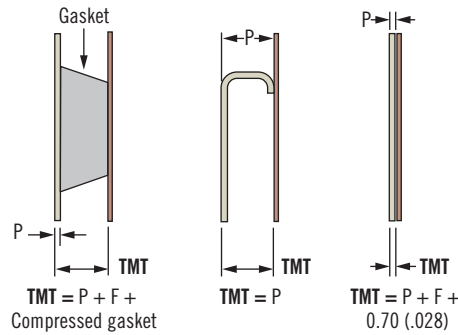
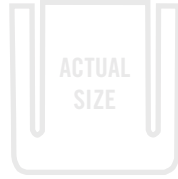
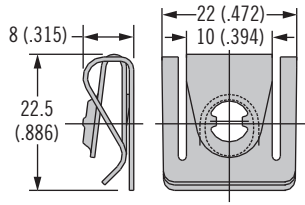

Material and Finish

Steel, zinc immersion coating

Part Number

See table

Notes

Utilize stud selection column indicated when choosing a stud length from the stud length table on page 393

Part Number	Stud Selection Column
D8-334-300-121	B

Front Mount

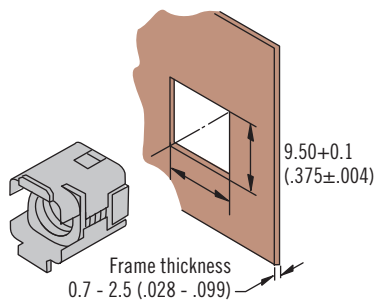
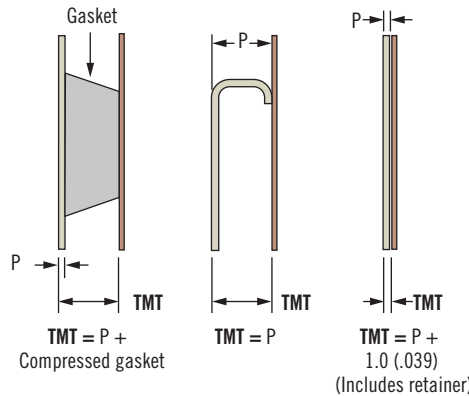
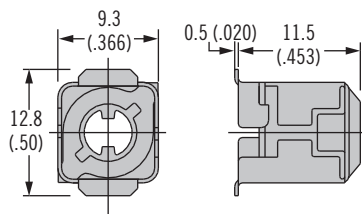

Material and Finish

Steel, zinc plated and stainless steel

Part Number

See table

Notes

Utilize stud selection column indicated when choosing a stud length from the stud length table on page 393

Installation

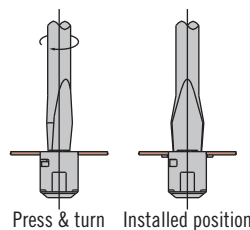

Part Number	Stud Selection Column
D8-334-200-190	C



D8 DZUS® PANEX Quarter-Turn Fasteners

Receptacles · Size 4

Material and Finish

Brass and steel, zinc plated

Installation Notes

Press receptacle flush to frame

Notes

Receptacle shown installed flush to the frame. To eliminate the gap between the frame and outer panel, install to a depth \geq the thickness of the selected retainer. This depth should be added to the TMT.

Press-In - Front Mount

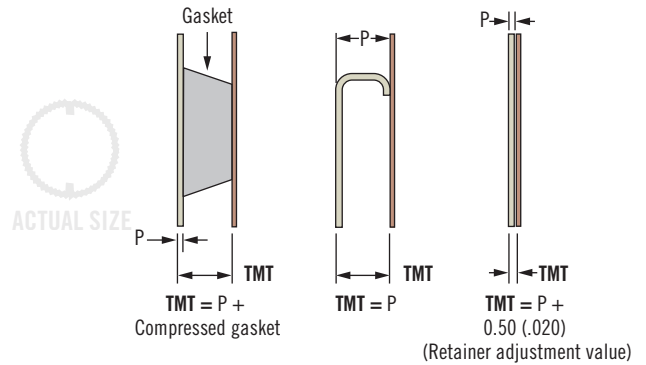
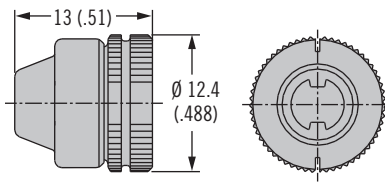

Solid Install

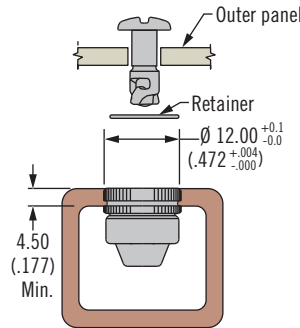

Blind Install

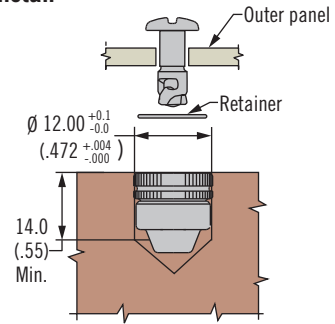

Part Number	Stud Selection Column
D8-334-100-300	D

Part Number

See table

Notes

Utilize stud selection column indicated when choosing a stud length from the stud length table on page 393

Material and Finish

Steel, zinc plated

Notes

For use in low carbon steels, aluminum and stainless steels in the annealed condition that are RB85 or softer

See page 543 for installation guidelines

Press-In - Self-Clinching

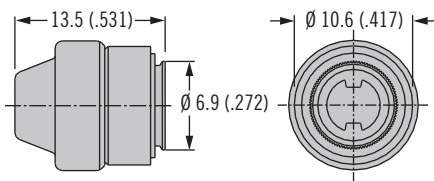

ACTUAL SIZE

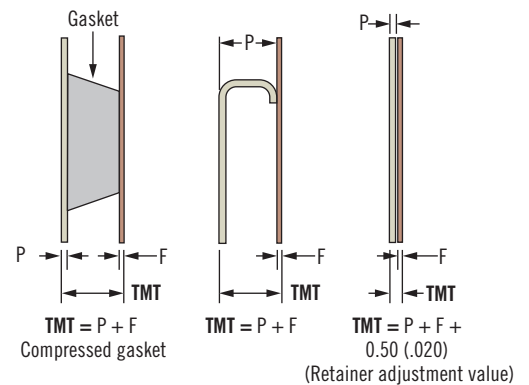
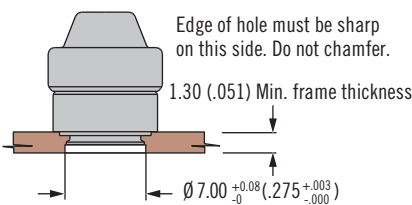

Part Number	Stud Selection Column
D8-334-110-190	E

Part Number

See table

Notes

Utilize stud selection column indicated when choosing a stud length from the stud length table on page 393



D8 DZUS® PANEX Quarter-Turn Fasteners

Retainers · Accessories · Size 4



Retainer Push-On

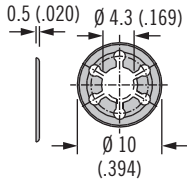

Retainer Push-On Plastic

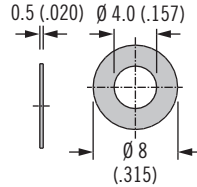

Type	Part Number	Material	Adjustment Value
Push-on plastic	D8-324-100-040	High density polyethylene, black	Included in TMT calculation
Push-on	D8-324-101-200	Stainless steel	

Material and Finish

See table

Part Number

See table

82

85

D8

D9

D1

D4

D5

D7

NY



Retainer Spring (Must be secured with steel retainer)

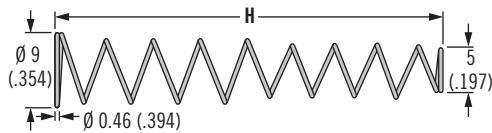

With Retaining Spring

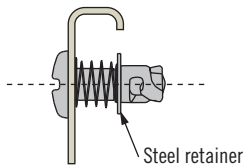

Without Retaining Spring

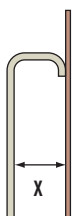
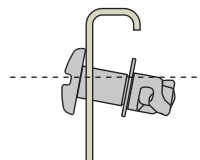

Part Number	H	X Min.	X Max.
D8-324-200-200	48 (1.89)	14 (.551)	44 (1.73)
D8-324-201-200	20 (.787)	5 (.197)	16 (.630)



D8 DZUS® PANEX Quarter-Turn Fasteners

Studs · Size 6

Material and Finish

Studs: Steel, zinc plated and chromate or chrome plated or stainless steel

Key: Steel with zinc plate and chromate

Bail cover: ABS, black

Accessories

Tamper resistant stud key:
Part number: D8-316-007-969

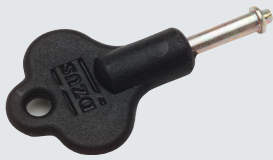

82

85

D8

D9

D1

D4

D5

D7

NY



Installation Notes

Bail cover: A Retainer must be fitted under the stud head to fit flush with surface

Retainer part number D8-326-100-040 (see page 403)

H Head Styles - Tool Actuated

Oval Slot

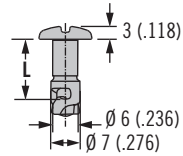
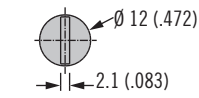

Hex Recess

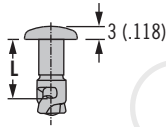
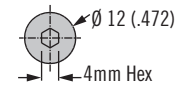

Phillips Recess

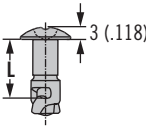
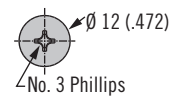

Tamper Resistant

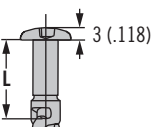
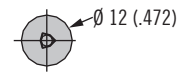

H Head Styles - Hand Actuated

Wing

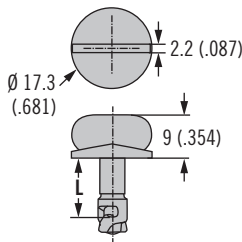

Bail

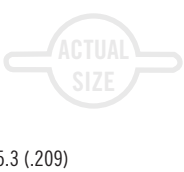
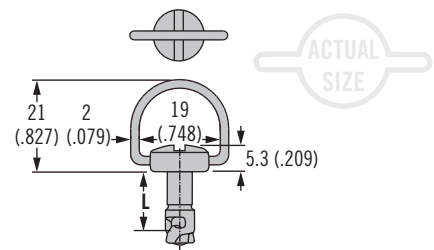

Optional Bail Cover

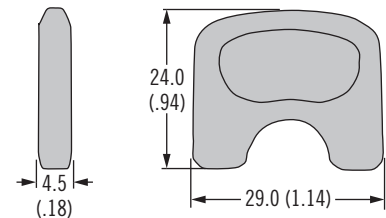
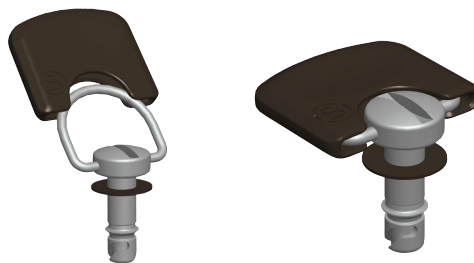

Bail Cover Part Number
D8-6-B-000

Stud Panel Preparation

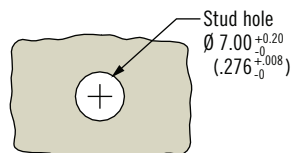

D8 DZUS® PANEX Quarter-Turn Fasteners

Stud selection · Size 6



Part Number Selection

H Head style

- 1 Slot recess
- 2 Hex recess
- 3 Wing
- 4 Bail (standard stud only)
- 6 Tamper resistant
- 7 Phillips recess

F Finish

- 170 Chrome plated
- 190 Zinc plated
- 191 Zinc plated, black
- 200 Stainless Steel (Slot recess, Hex recess, Phillips recess)

D8 - 316 - H K - F

K Length

Enter number from selection table below

Stud Length Table											
A		B		C		D		E		K	L ±.15 ±(.006)
Min.	Max.	Min.	Max.	Min.	Max.	Min.	Max.	Min.	Max.		
TMT Range For: D8-336-400-121 D8-336-500-121		TMT Range For: D8-336-300-121 D8-336-310-121 D8-336-330-121		TMT Range For: D8-336-200-190		TMT Range For: D8-336-100-300		TMT Range For: D8-336-110-190			
~	~	1.5 (.06)	2.4 (.09)	~	~	~	~	~	~	09	9 (.354)
2.5 (.10)	3.4 (.13)	2.5 (.10)	3.4 (.13)	~	~	~	~	~	~	10	10 (.394)
3.5 (.14)	4.4 (.17)	3.5 (.14)	4.4 (.17)	~	~	~	~	~	~	11	11 (.433)
4.5 (.18)	5.4 (.21)	4.5 (.18)	5.4 (.21)	~	~	0.7 (.03)	1.6 (.06)	1.7 (.07)	2.6 (.10)	12	12 (.472)
5.5 (.22)	6.4 (.25)	5.5 (.22)	6.4 (.25)	~	~	1.7 (.07)	2.6 (.10)	2.7 (.11)	3.6 (.14)	13	13 (.512)
6.5 (.26)	7.4 (.29)	6.5 (.26)	7.4 (.29)	~	~	2.7 (.11)	3.6 (.14)	3.7 (.15)	4.6 (.18)	14	14 (.551)
7.5 (.30)	8.4 (.33)	7.5 (.30)	8.4 (.33)	~	~	3.7 (.15)	4.6 (.18)	4.7 (.19)	5.6 (.22)	15	15 (.591)
8.5 (.33)	9.4 (.37)	8.5 (.33)	9.4 (.37)	0.8 (.03)	1.7 (.07)	4.7 (.19)	5.6 (.22)	5.7 (.22)	6.6 (.26)	16	16 (.630)
9.5 (.37)	10.4 (.41)	9.5 (.37)	10.4 (.41)	1.8 (.07)	2.7 (.11)	5.7 (.22)	6.6 (.26)	6.7 (.26)	7.6 (.30)	17	17 (.669)
10.5 (.41)	11.4 (.45)	10.5 (.41)	11.4 (.45)	2.8 (.11)	3.7 (.15)	6.7 (.26)	7.6 (.30)	7.7 (.30)	8.6 (.34)	18	18 (.709)
11.5 (.45)	12.4 (.49)	11.5 (.45)	12.4 (.49)	3.8 (.15)	4.7 (.19)	7.7 (.30)	8.6 (.34)	8.7 (.34)	9.6 (.38)	19	19 (.748)
12.5 (.49)	13.4 (.53)	12.5 (.49)	13.4 (.53)	4.8 (.19)	5.7 (.22)	8.7 (.34)	9.6 (.38)	9.7 (.38)	10.6 (.42)	20	20 (.787)
13.5 (.53)	14.4 (.57)	13.5 (.53)	14.4 (.57)	5.8 (.23)	6.7 (.26)	9.7 (.38)	10.6 (.42)	10.7 (.42)	11.6 (.46)	21	21 (.827)
14.5 (.57)	15.4 (.61)	14.5 (.57)	15.4 (.61)	6.8 (.27)	7.7 (.30)	10.7 (.42)	11.6 (.46)	11.7 (.46)	12.6 (.50)	22	22 (.866)
15.5 (.61)	16.4 (.65)	15.5 (.61)	16.4 (.65)	7.8 (.31)	8.7 (.34)	11.7 (.46)	12.6 (.50)	12.7 (.50)	13.6 (.54)	23	23 (.906)
16.5 (.65)	17.4 (.69)	16.5 (.65)	17.4 (.69)	8.8 (.35)	9.7 (.38)	12.7 (.50)	13.6 (.54)	13.7 (.54)	14.6 (.57)	24	24 (.945)
17.5 (.69)	18.4 (.72)	17.5 (.69)	18.4 (.72)	9.8 (.39)	10.7 (.42)	13.7 (.54)	14.6 (.57)	14.7 (.58)	15.6 (.61)	25	25 (.984)
18.5 (.73)	19.4 (.76)	18.5 (.73)	19.4 (.76)	10.8 (.43)	11.7 (.46)	14.7 (.58)	15.6 (.61)	15.7 (.62)	16.6 (.65)	26	26 (1.02)
19.5 (.77)	20.4 (.80)	19.5 (.77)	20.4 (.80)	11.8 (.46)	12.7 (.50)	15.7 (.62)	16.6 (.65)	16.7 (.66)	17.6 (.69)	27	27 (1.06)
20.5 (.81)	21.4 (.84)	20.5 (.81)	21.4 (.84)	12.8 (.50)	13.7 (.54)	16.7 (.66)	17.6 (.69)	17.7 (.70)	18.6 (.73)	28	28 (1.10)
21.5 (.85)	22.4 (.88)	21.5 (.85)	22.4 (.88)	13.8 (.54)	14.7 (.58)	17.7 (.70)	18.6 (.73)	18.7 (.74)	19.6 (.77)	29	29 (1.14)
22.5 (.89)	23.4 (.92)	22.5 (.89)	23.4 (.92)	14.8 (.58)	15.7 (.62)	18.7 (.74)	19.6 (.77)	19.7 (.78)	20.6 (.81)	30	30 (1.18)

To select correct fastener:

1. Select receptacle

Choose a receptacle from pages 400-402

2. Select retainer and accessories

from page 403 and note any adjustment values

3. Specify stud length

Calculate the total material thickness (TMT) using the formula given for the receptacle selected. Find the range of TMT using the stud length selection table (left) using the column (A, B, C, D or E) given for the receptacle selected.

4. Complete the stud part number

by specifying the head style **H**, stud length **K**, and material **M**

Example:

For rivet-on

D8-336-400-121 use column A
For TMT value calculated as 5.2 (.206), K = 12

For slotted head style in steel material, completed part number: D8-316-112-190

A complete example can be found on page 377.

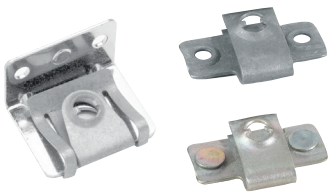

D8 DZUS® PANEX Quarter-Turn Fasteners

Receptacles · Size 6

Material and Finish

Steel, zinc immersion coating or stainless steel

Installation Notes

Install with $\varnothing 3$ (.125) rivets

Part Number

See table

Notes

Utilize stud selection column indicated when choosing a stud length from the stud length table on page 399

Rivet-On

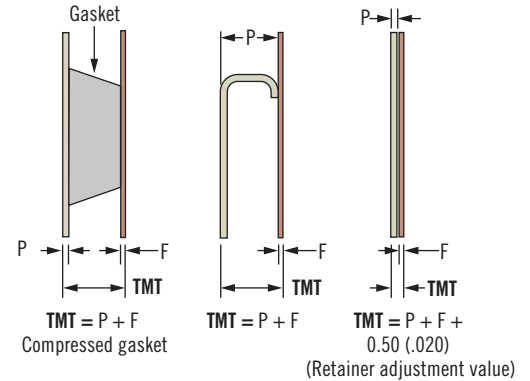
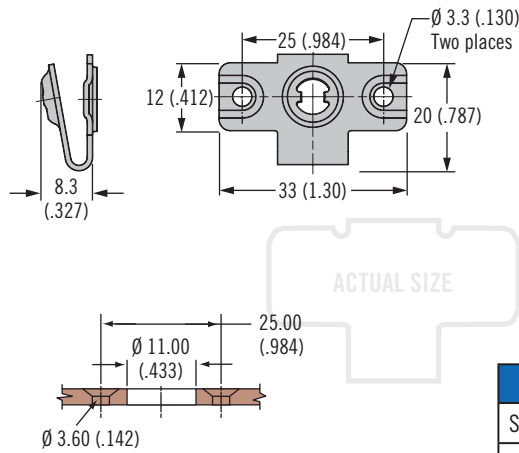

Part Number		Stud Selection Column
Steel	D8-336-400-121	A
Stainless steel	D8-336-400-200	

Material and Finish

Steel, zinc immersion coating

Part Number

See table

Notes

Utilize stud selection column indicated when choosing a stud length from the stud length table on page 399

Weld-On

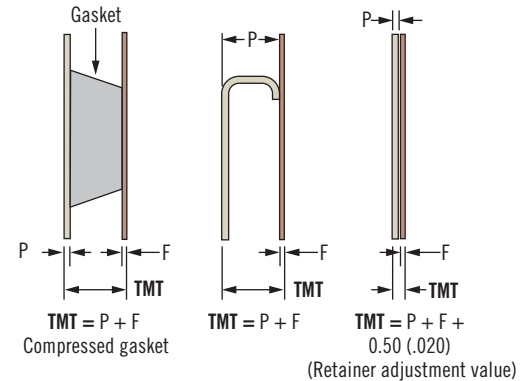
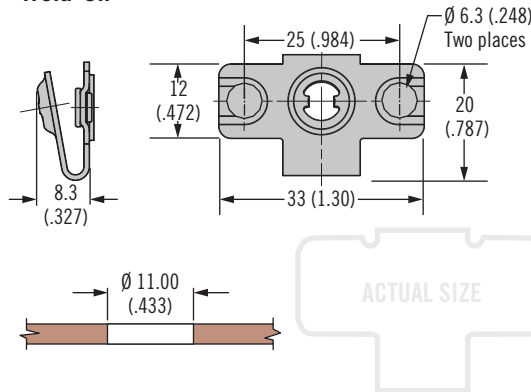

Part Number	Stud Selection Column
D8-336-500-121	A

Material and Finish

Steel, zinc immersion coating

Part Number

See table

Notes

Utilize stud selection column indicated when choosing a stud length from the stud length table on page 399

Side Mount

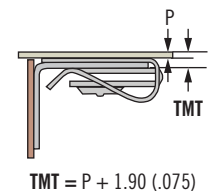
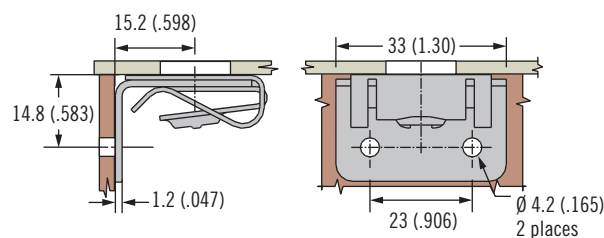

Part Number	Stud Selection Column
D8-336-310-121	B

D8 DZUS® PANEX Quarter-Turn Fasteners

Receptacles · Size 6

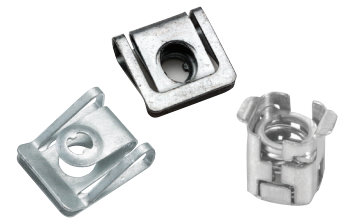

Clip-On

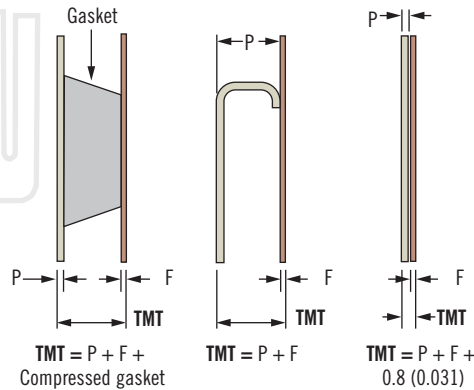
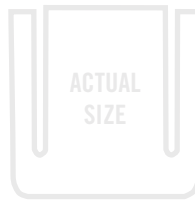
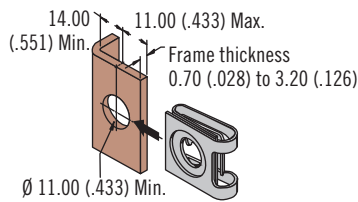
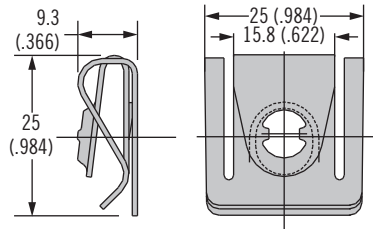

Part Number	Stud Selection Column
D8-336-300-121	B

Material and Finish

Steel, zinc immersion coating

Part Number

See table

Notes

Utilize stud selection column indicated when choosing a stud length from the stud length table on page 399

82

85

D8

D9

D1

D4

D5

D7

Clip-On - Mini

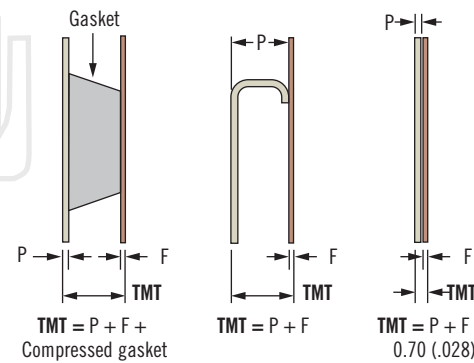
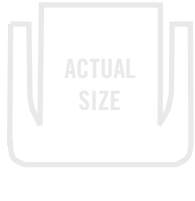
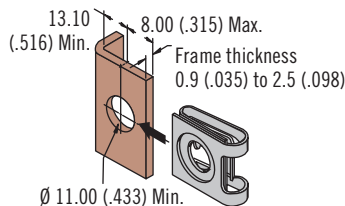
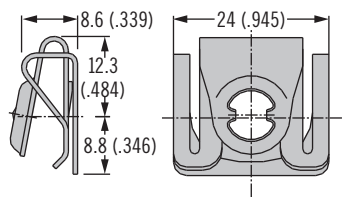

Part Number	Stud Selection Column
Steel D8-336-330-121	B
Stainless steel D8-336-330-200	

Material and Finish

Steel, zinc immersion coating or stainless steel

Part Number

See table

Notes

Utilize stud selection column indicated when choosing a stud length from the stud length table on page 399

NY



Front Mount

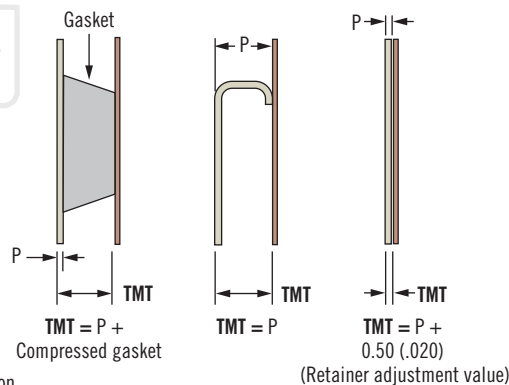
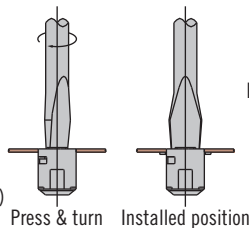
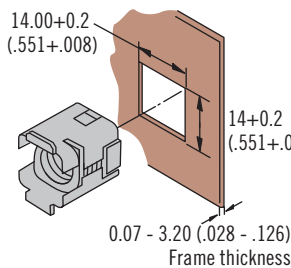
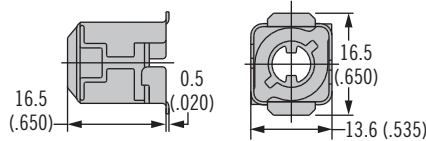

Part Number	Stud Selection Column
D8-336-200-190	C

Material and Finish

Steel, zinc plated and stainless steel

Part Number

See table

Notes

Utilize stud selection column indicated when choosing a stud length from the stud length table on page 399



D8 DZUS® PANEX Quarter-Turn Fasteners

Receptacles · Size 6

Material and Finish

Brass and steel, zinc plated

Installation Notes

Press receptacle flush to frame

Notes

Receptacle shown installed flush to the frame. To eliminate the gap between the frame and outer panel, install to a depth \geq the thickness of the selected retainer. This depth should be added to the TMT.

Part Number

See table

Notes

Utilize stud selection column indicated when choosing a stud length from the stud length table on page 399

Press-In - Front Mount

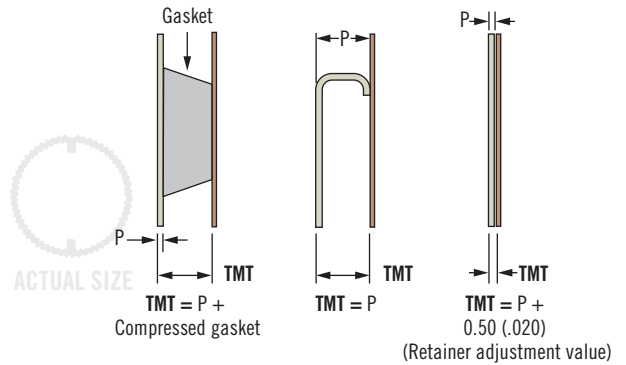
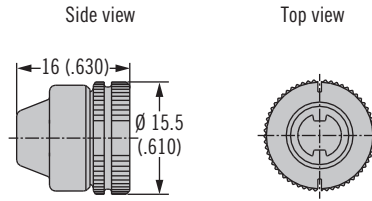

Solid Install

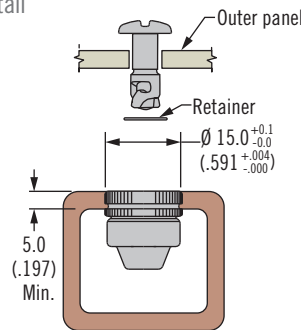

Blind Install

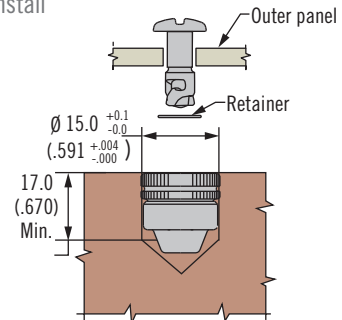

Part Number	Stud Selection Column
D8-336-100-300	D

Material and Finish

Steel, zinc plated

Installation Notes

See page 543 for installation guidelines

Press-In - Self-Clinching

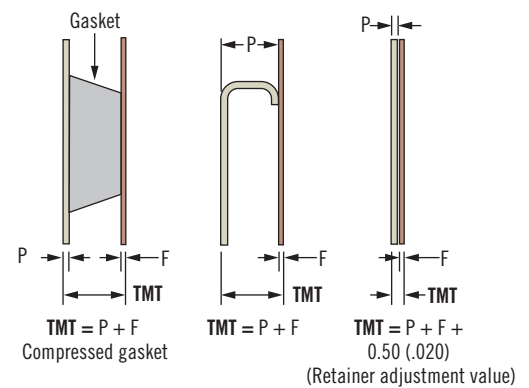
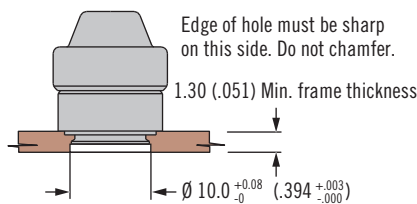
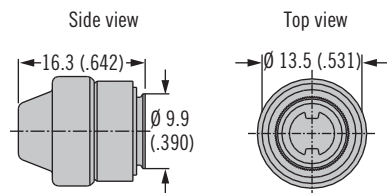

Part Number

See table

Notes

Utilize stud selection column indicated when choosing a stud length from the stud length table on page 399

Part Number	Stud Selection Column
D8-336-110-190	E



D8 DZUS® PANEX Quarter-Turn Fasteners

Retainers and Accessories · Size 6



403

Retainer Push-On, Stainless Steel

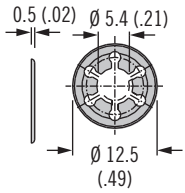

Retainer Push-On, Plastic

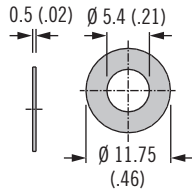

Cupped Washer

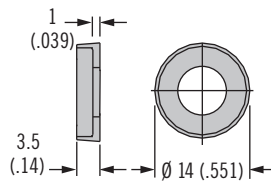

Ejector Spring

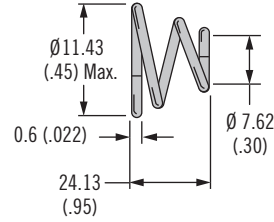

Ejector Spring and Cup Assembly

(Must be secured with stainless steel retainer)

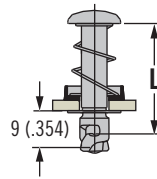

Type	Part Number	Material	Adjustment Value
Push-on plastic	D8-326-100-040	High density polyethylene, black	Included in TMT calculation
Push-on	D8-326-101-200	Stainless steel	
Cupped washer	D8-376-001-049	Thermoplastic, black	Add 1.00 (.039)
Ejector spring	D4-EHF5-3-950QA	Stainless steel	Add 1.00 (.039)

Material and Finish

See table

Accessories

When using the ejecting version add 2 (.079) to your TMT

Notes

Cupped washer only available for tool recess head styles (slot, Phillips, hex, tamper resistant)

Assembly consists of spring, cup and stud ordered separately, shipped bulk

Part Number

See table

Retainer Spring (Must be secured with steel retainer)

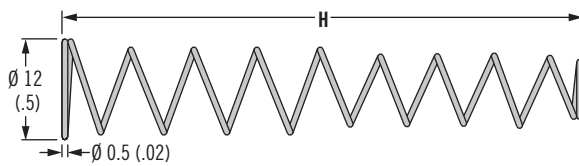

With Retaining Spring

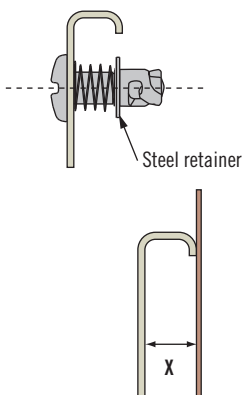

Without Retaining Spring

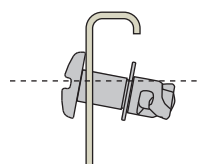

Part Number	H	X Min.	X Max.
D8-326-200-200	48 (1.89)	19 (.75)	44 (1.73)
D8-326-201-200	25 (.98)	5 (.197)	21 (.83)



D8 DZUS® PANEX Quarter-Turn Fasteners

Studs · Size 9

Material and Finish

Studs: Steel, zinc plated and chromate or chrome plated

82

85

D8

D9

D1

D4

D5

D7

NY

H Head Styles - Tool Actuated

Oval Slot

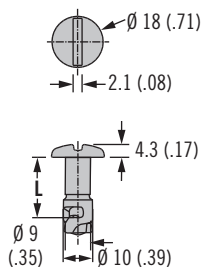

Hex Recess

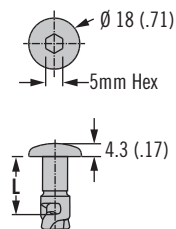

Phillips Recess

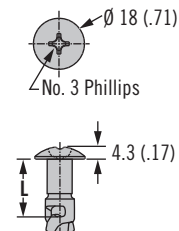

H Head Styles - Hand Actuated

Wing

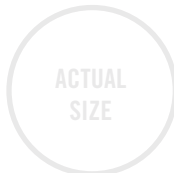
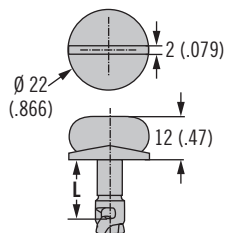

Bail

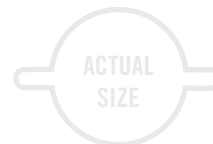
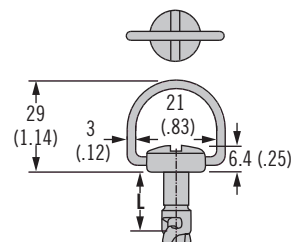

Stud Panel Preparation

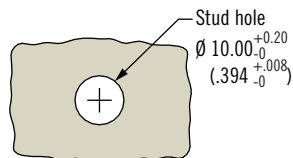

Dimensions in millimeters (inch) unless otherwise stated



www.southco.com/D8

DZUS®

southco®
CONNECT · CREATE · INNOVATE

D8 DZUS® PANEX Quarter-Turn Fasteners

Stud selection · Size 9

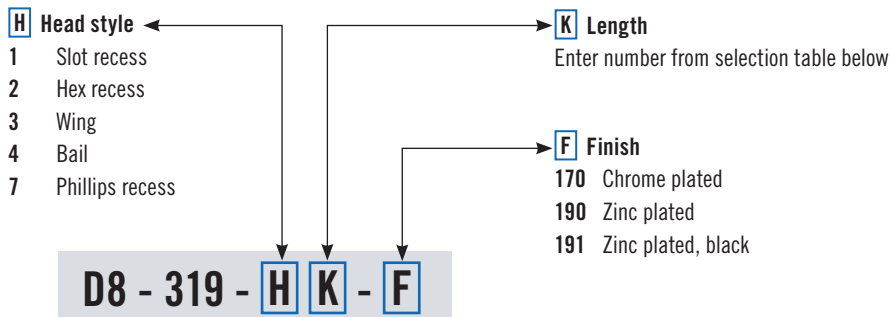

Part Number Selection

- 82
- 85
- D8**
- D9
- D1
- D4
- D5
- D7
- NY

To select correct fastener:

1. Select receptacle

Choose a receptacle from pages 406-408

2. Select retainer and accessories

from page 409 and note any adjustment values

3. Specify stud length

Calculate the total material thickness (TMT) using the formula given for the receptacle selected. Find the range of TMT using the stud length selection table (left) using the column (A, or B) given for the receptacle selected.

4. Complete the stud part number

by specifying the head style **H**, stud length **K**, and material **M**

Example:

For rivet-on

D8-339-400-121 use column A
For TMT value calculated as 5.2 (.206), K = 13

For slotted head style in steel, zinc plated material, completed part number: D8-319-113-190

A complete example can be found on page 377.

Notes

Stainless steel material may require a higher minimum order quantity. Contact Southco for details.

Stud Length Table					
A		B		K	L ±.15 (.006)
TMT Range For: D8-339-400-121 D8-339-500-121 D8-339-300-121 D8-339-301-121 D8-339-305-121		TMT Range For: D8-339-200-190			
Min.	Max.	Min.	Max.		
3.0 (.12)	3.9 (.15)	~	~	11	11 (.433)
4.0 (.16)	4.9 (.19)	~	~	12	12 (.472)
5.0 (.20)	5.9 (.23)	~	~	13	13 (.512)
6.0 (.24)	6.9 (.27)	~	~	14	14 (.551)
7.0 (.28)	7.9 (.31)	~	~	15	15 (.591)
8.0 (.31)	8.9 (.35)	~	~	16	16 (.630)
9.0 (.35)	9.9 (.39)	~	~	17	17 (.669)
10.0 (.39)	10.9 (.43)	~	~	18	18 (.709)
11.0 (.43)	11.9 (.47)	~	~	19	19 (.748)
12.0 (.47)	12.9 (.51)	~	~	20	20 (.787)
13.0 (.51)	13.9 (.55)	~	~	21	21 (.827)
14.0 (.55)	14.9 (.59)	2.5 (.10)	3.4 (.13)	22	22 (.866)
15.0 (.59)	15.9 (.63)	3.5 (.14)	4.4 (.17)	23	23 (.906)
16.0 (.63)	16.9 (.67)	4.5 (.18)	5.4 (.21)	24	24 (.945)
17.0 (.67)	17.9 (.70)	5.5 (.22)	6.4 (.25)	25	25 (.984)
18.0 (.71)	18.9 (.74)	6.5 (.26)	7.4 (.29)	26	26 (1.02)
19.0 (.75)	19.9 (.78)	7.5 (.30)	8.4 (.33)	27	27 (1.06)
20.0 (.79)	20.9 (.82)	8.5 (.33)	9.4 (.37)	28	28 (1.10)
21.0 (.83)	21.9 (.86)	9.5 (.37)	10.4 (.41)	29	29 (1.14)
22.0 (.87)	22.9 (.90)	10.5 (.41)	11.4 (.45)	30	30 (1.18)



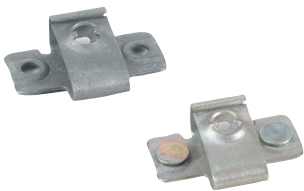

D8 DZUS® PANEX Quarter-Turn Fasteners

Receptacles · Size 9

Material and Finish

Steel, zinc immersion coating

Installation Notes

Install with Ø 3 (.125) rivets

Rivet-On

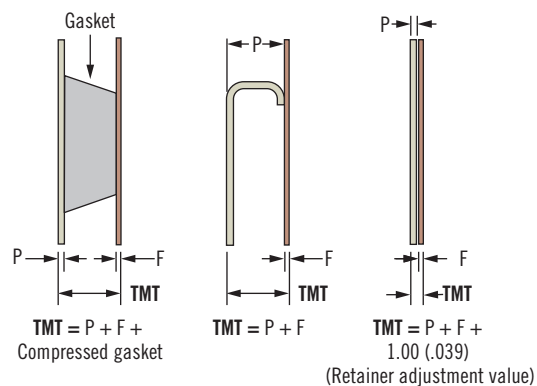
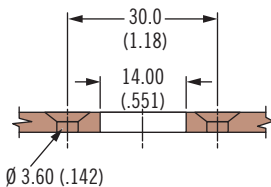
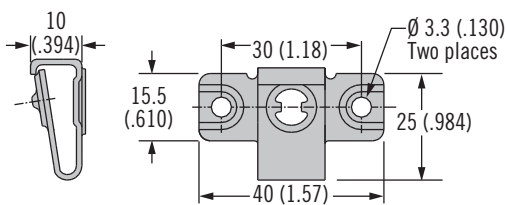

Part Number	Stud Selection Column
D8-339-400-121	A

Part Number

See table

Notes

Utilize stud selection column indicated when choosing a stud length from the stud length table on page 405

Material and Finish

Steel, zinc immersion coating

Weld-On

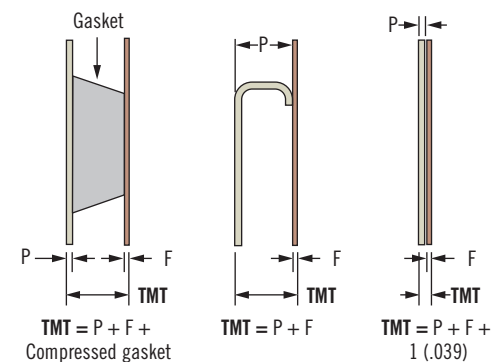
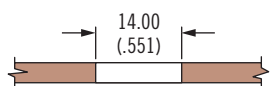
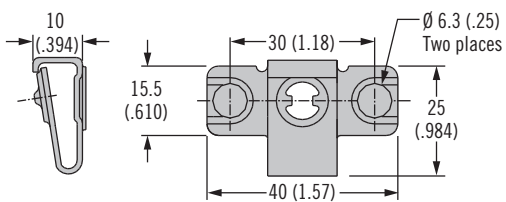

Part Number	Stud Selection Column
D8-339-500-121	A

Part Number

See table

Notes

Utilize stud selection column indicated when choosing a stud length from the stud length table on page 405



D8 DZUS® PANEX Quarter-Turn Fasteners

Receptacles · Size 9

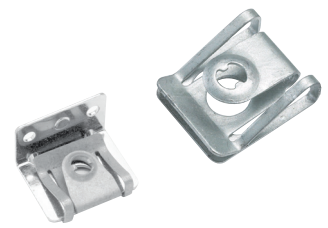

407

Side Mount

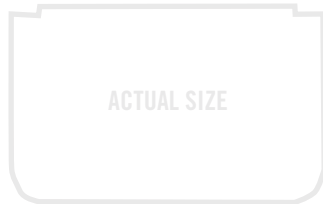
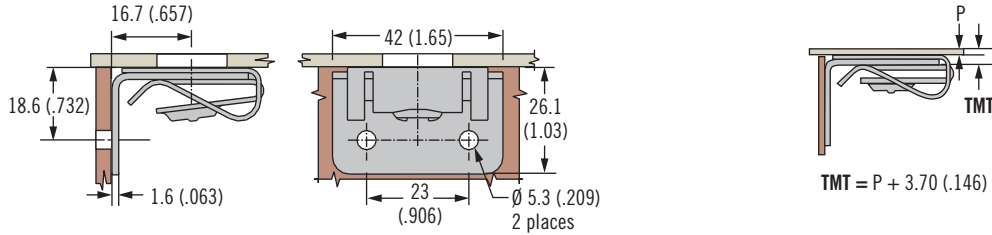

Material and Finish

Steel, zinc immersion coating

82

85

D8

D9

D1

D4

D5

D7

NY



Part Number

See table

Notes

Utilize stud selection column indicated when choosing a stud length from the stud length table on page 405

Part Number	Stud Selection Column
D8-339-305-121	A

Clip-On

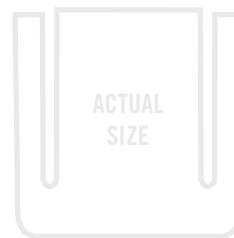
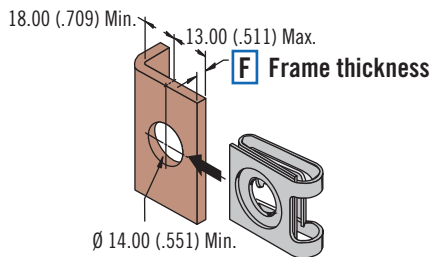
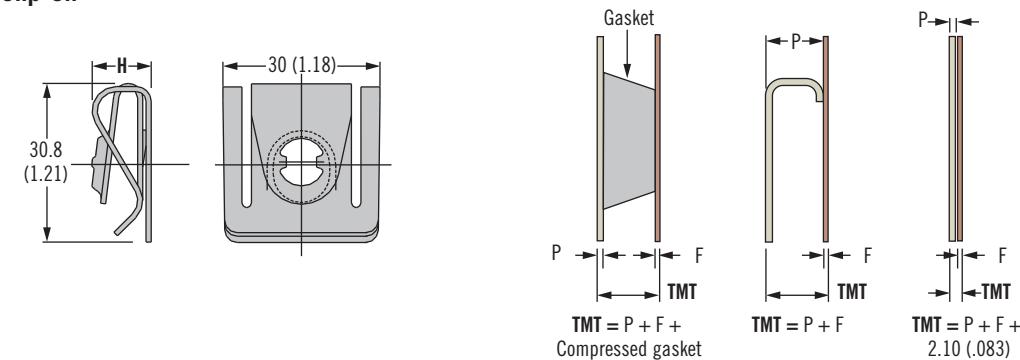

Material and Finish

Steel, zinc immersion coating

Part Number

See table

Notes

Utilize stud selection column indicated when choosing a stud length from the stud length table on page 405

F Frame Thickness Range	Part Number	H	Stud Selection Column
0.7 - 3.2 (.028 - .126)	D8-339-300-121	10.7 (.421)	A
3.2 - 5.5 (.126 - .217)	D8-339-301-121	11.3 (.445)	



D8 DZUS® PANEX Quarter-Turn Fasteners

Receptacles · Size 9

Material and Finish

Steel, zinc plated

82

85

D8

D9

D1

D4

D5

D7

NY

Front Mount

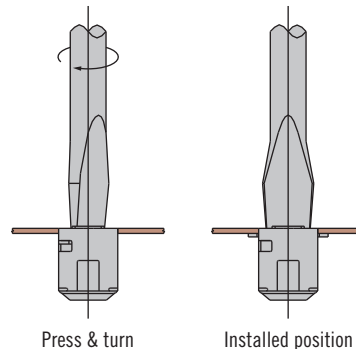
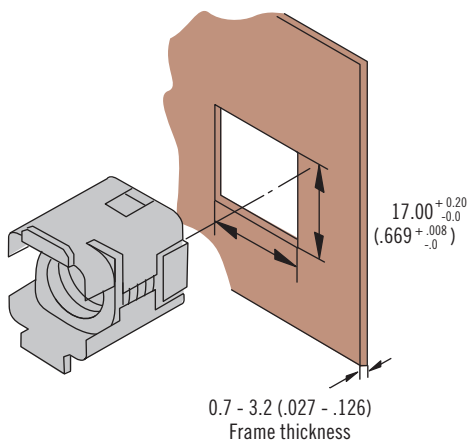
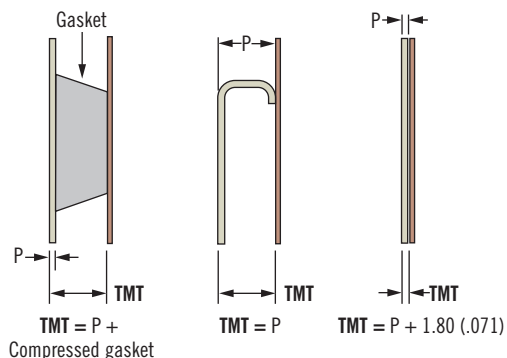
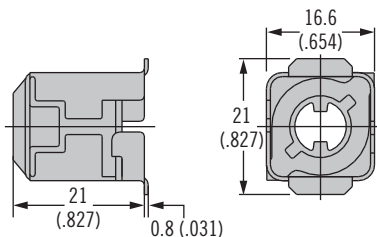

Part Number

See table

Notes

Utilize stud selection column indicated when choosing a stud length from the stud length table on page 405

Type	Part Number	Stud Selection Column
Front mount	D8-339-200-190	B



D8 DZUS® PANEX Quarter-Turn Fasteners

Retainers and accessories · Size 9



Retainer Push-On, Plastic

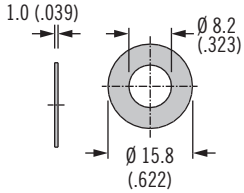

Retainer Push-On, Steel

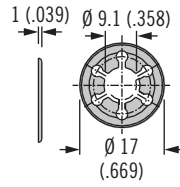

Type	Part Number	Material	Adjustment Value
Push-on Plastic	D8-329-101-040	Nylon 6/6 Black	Included in TMT calculation
Push-on	D8-329-101-200	Stainless steel	

Material and Finish

See table

82

85

D8

D9

D1

D4

D5

D7

NY



Retainer Spring (Must be secured with steel retainer)

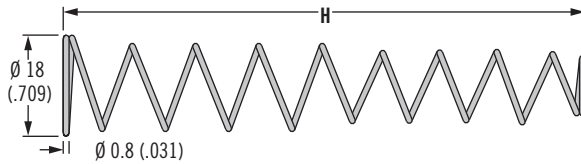

With Retaining Spring

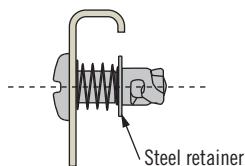

Without Retaining Spring

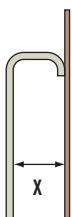
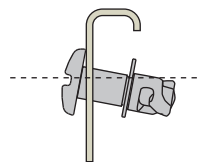

Part Number	H	X Min.	X Max.
D8-329-200-200	48 (1.89)	7 (.276)	43 (1.69)

Installation Guidelines

for *SOUTHCO*® Self-Clinching products

Self-clinching product installation is offered on these *SOUTHCO*® products, making them easy-to-use captive panel fasteners:

- Captive Screws
- Receptacles for Quarter-turn Fasteners
- Receptacles for Fast-lead Thread Screws

When pressed into a properly prepared hole, self-clinching captive fasteners cold-flow (move) the panel material into the retaining groove of the fastener. This material then retains the fastener in the panel.

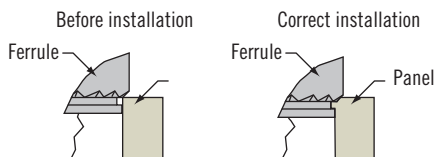

Successful press-in installations depend on:

Material:

The hardness of the panel material must not exceed *SOUTHCO*® recommendations. If the panel is too hard, the fastener will not install correctly.

Installation Holes:

Mounting holes may be drilled, punched, or cast.

- Hole edge: the top hole edge must be sharp but with no broken edges.

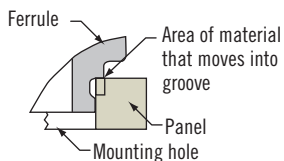

Do not chamfer or debur edge.

- Punched holes: use a punch and die with a small clearance to minimize the rollover and fracture angle.
- Hole diameter: measure the hole diameter at the panel surface on the side on which the fastener will be installed. The diameter must be within *SOUTHCO*® specifications for that product.

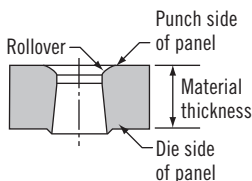

- If the hole is too large, not enough material will flow into the

retaining groove and the fastener may not be retained adequately.

- If the hole is too small, the fastener will not fit and installation may become difficult and unsafe.
- Hole distance from the edge of panel: the minimum recommended distance is 1.5 x the diameter of the mounting hole, unless otherwise indicated.

- Spring-loaded Plungers
- Captive Nuts
- Threaded Inserts

- Installing too close to the edge will cause the material to flow in the opposite direction, deforming the edge of the panel. To install closer to the edge, you may need to restrain the panel edge.

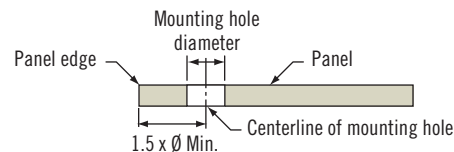

Panel Thickness:

The thickness of the panel at the mounting hole location must meet or exceed Southco's stated minimum recommendations.

If the material is too thin, panel deformation and/or damage to the fastener may result.

Installation is fast and easy if you follow these tips:

How to install: Use the recommended force where noted and a proper back-up tool.

- use any parallel-acting press
- use a punch whose diameter is larger than the head of the fastener

Installation Force: Proper installation requires an even distribution of adequate force. It does not depend on the distance the fastener is pressed into the panel.

- Southco does not recommend using a hammer. The impact force does not provide an even distribution of force to allow the panel material to completely flow into the fastener's retaining groove.
- Installation force varies from application to application, depending on the criteria noted above.
- On parts without a collar to provide a hard stop, press-in until the edge of the knurl is just barely visible.

When to Install:

Installation is recommended after plating or finishing has been applied to the panel.

The hole diameter must meet specifications before finish or plating is applied.

- Do not over-install parts. This interrupts the material and will reduce the retention strength.

