

REVISION HISTORY			
REV	DATE	BY	DESCRIPTION
C	25AUG2015	MJS/JJT	PRN: P2015-1734

ASSEMBLY NO.	POSITION TORQUE N-m (in-lbf)	DETENT OPEN ANGLE	SUB-ASSEMBLY NO.	COVER NO.
C6-221	0.7 (6)	80° DETENT	C6-251	C6-602
C6-222	1.1 (10)		C6-252	C6-602
C6-223	1.7 (15)		C6-253	C6-602
C6-224	0.7 (6)	115° DETENT	C6-254	C6-602
C6-225	1.1 (10)		C6-255	C6-602
C6-226	1.7 (15)		C6-256	C6-602
C6-227	0.7 (6)	150° DETENT	C6-257	C6-602
C6-228	1.1 (10)		C6-258	C6-602
C6-229	1.7 (15)		C6-259	C6-602
C6-220	-	NO DETENTS	C6-250	C6-602

ASSEMBLY PART NUMBERS SHOWN CONSIST OF 1 SUB-ASSEMBLY AND 2 COVERS, SHIPPED SEPARATELY, BULK.

### ADDITIONAL ASSEMBLY PART NUMBERS

FOR 1 SUBASSEMBLY AND 2 COVERS PACKAGED IN A POLY BAG, ADD -P TO THE PART NUMBER. EXAMPLE: C6-221-P

SUB-ASSEMBLIES AND COVERS ARE DESIGNED TO ACCOMODATE MOUNTING HARDWARE WITH A MAXIMUM HEAD DIAMETER OF 10.2 AND A MAXIMUM HEIGHT OF 3.0

### INSTALLATION INSTRUCTIONS:

1. PREPARE INSTALLATION HOLES AS SHOWN.
2. MOUNT HINGE SUB-ASSEMBLY WITH APPROPRIATE FASTENING HARDWARE (NOT SUPPLIED).
3. PRESS COVERS IN PLACE IF DESIRED TO HIDE THE MOUNTING HARDWARE. ALLOW 3mm OF CLEARANCE AROUND PROFILE OF HINGE FOR COVER INSTALLATION AND REMOVAL.

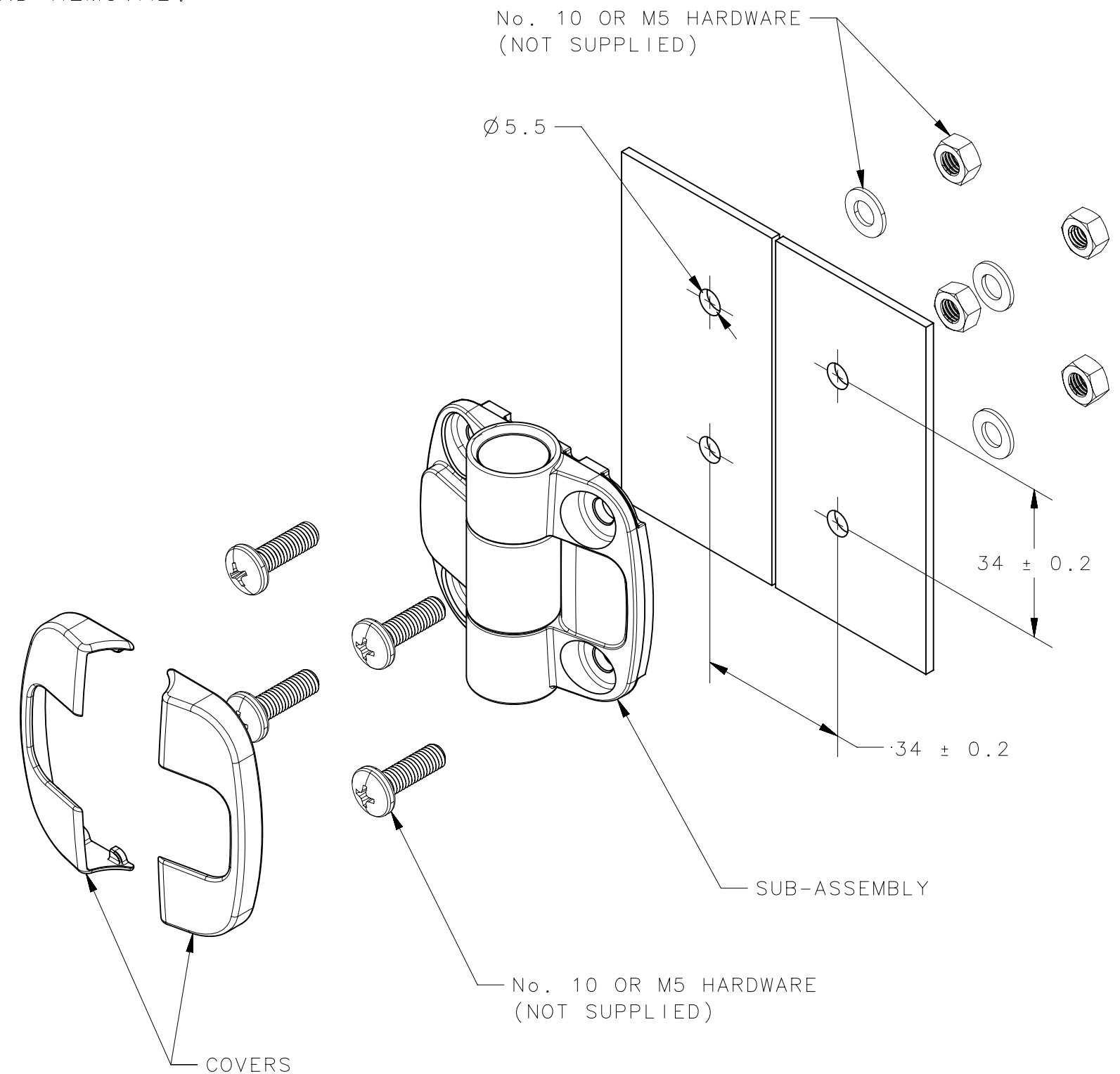
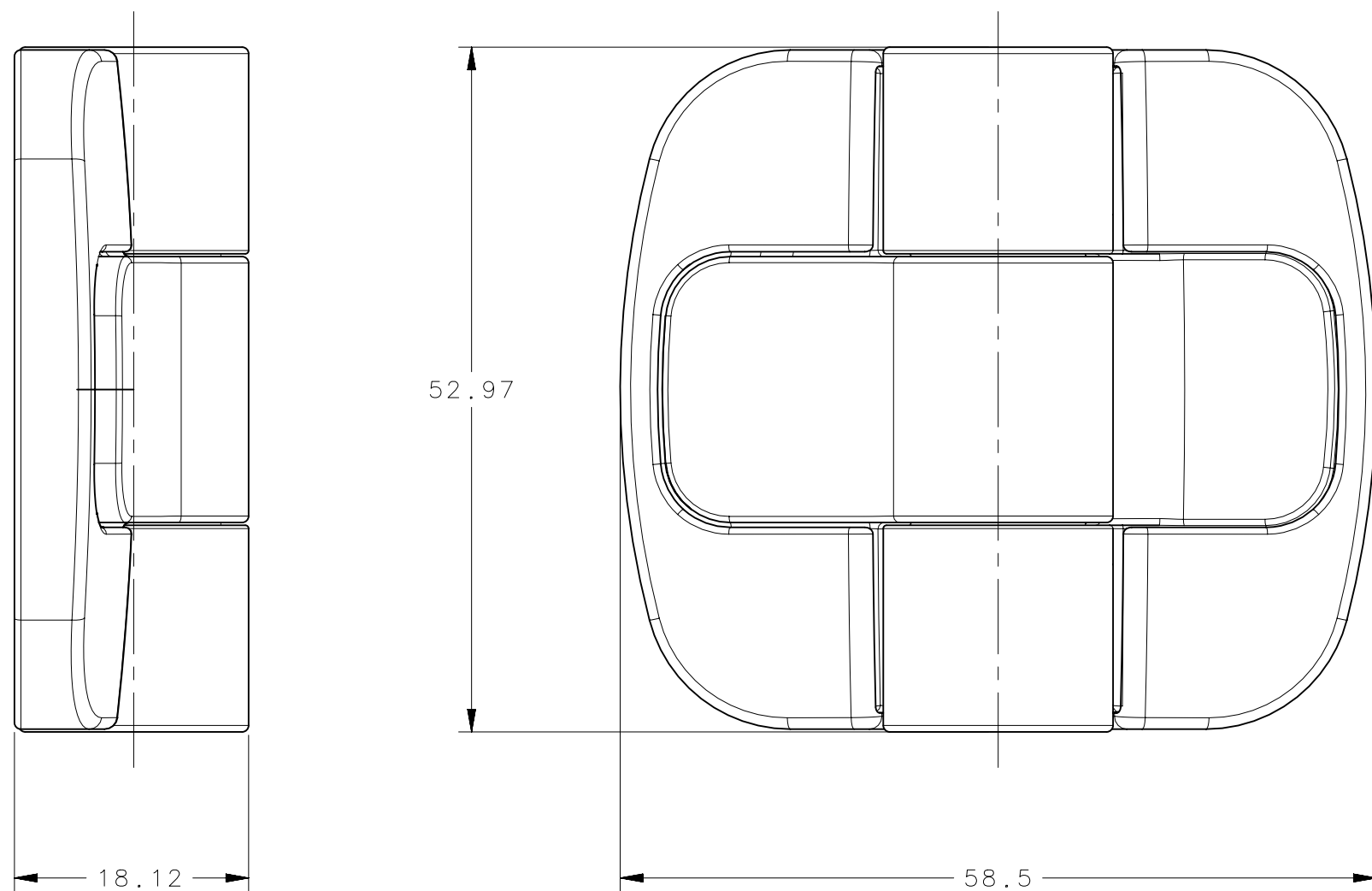

### MATERIAL AND FINISH:

#### EXTERNAL COMPONENTS

- HINGE LEAVES, COVERS, END PLUGS, SPRING COVER: ACETAL, BLACK.

#### INTERNAL COMPONENTS:

- BALLS AND SPRINGS: STAINLESS STEEL
- DETENT TUBE: STAINLESS STEEL, PASSIVATED

THIRD ANGLE PROJECTION			
MILLIMETERS [IN]			
SURFACE AREA mm <sup>2</sup>		DESCRIPTION C6 DOOR POSITIONING HINGE	
VOLUME mm <sup>3</sup>		SIZE SYSTEM DWG NO. C NX J-C6-200	
<small>PROPRIETARY ITEM EXCEPT FOR USES EXPRESSLY GRANTED IN WRITING, INFORMATION DISCLOSED HEREON IS CONFIDENTIAL AND ALL RIGHTS, PATENT AND OTHERWISE, ARE RESERVED BY SOUTHCO, INC.</small>		<small>TOLERANCES UNLESS OTHERWISE NOTED</small> ALL DIMENSIONS WITHOUT TOLERANCES ARE FOR REFERENCE ONLY. PER ASME Y14.5M-1994	
DRAWN BY		SCALE	
JJT		2:1	
DATE		SHEET	
25JUL2014		1 OF 1	