

REVISION HISTORY			
REV	DATE	BY	DESCRIPTION
B	20APR2015	JQ/LC	PRN: P2015-0766

PART NUMBER C2-43-21 SHOWN

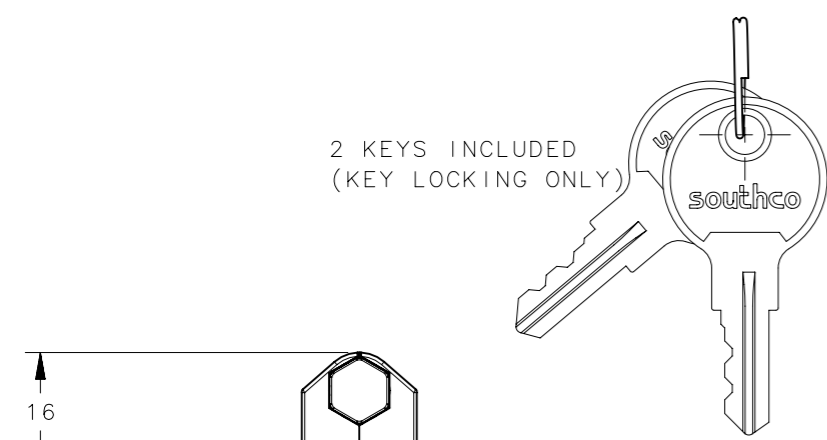

23 THRU 43 GRIP RANGE AS SHOWN
46 MAX GRIP WITH NUT
ON OTHER SIDE OF THE LEVER

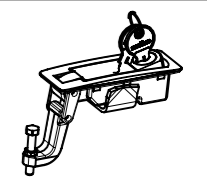
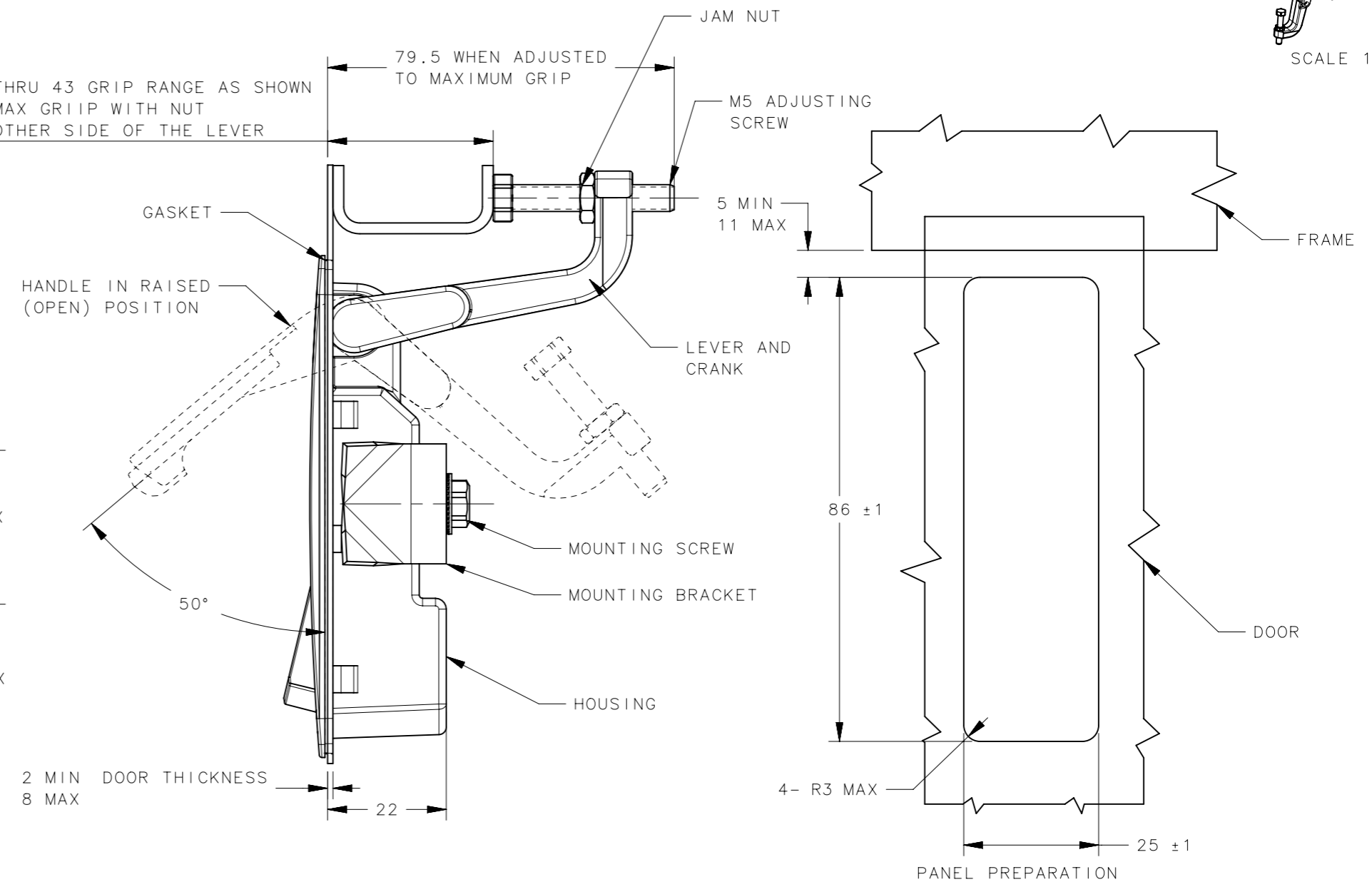
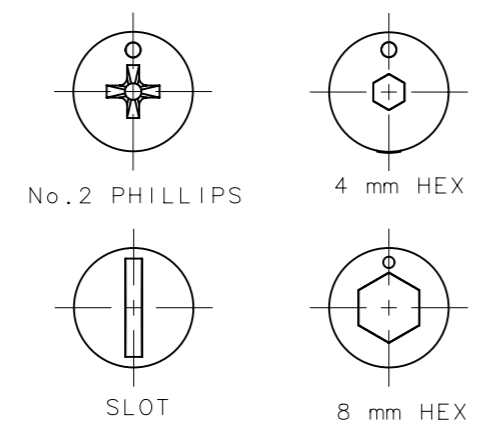
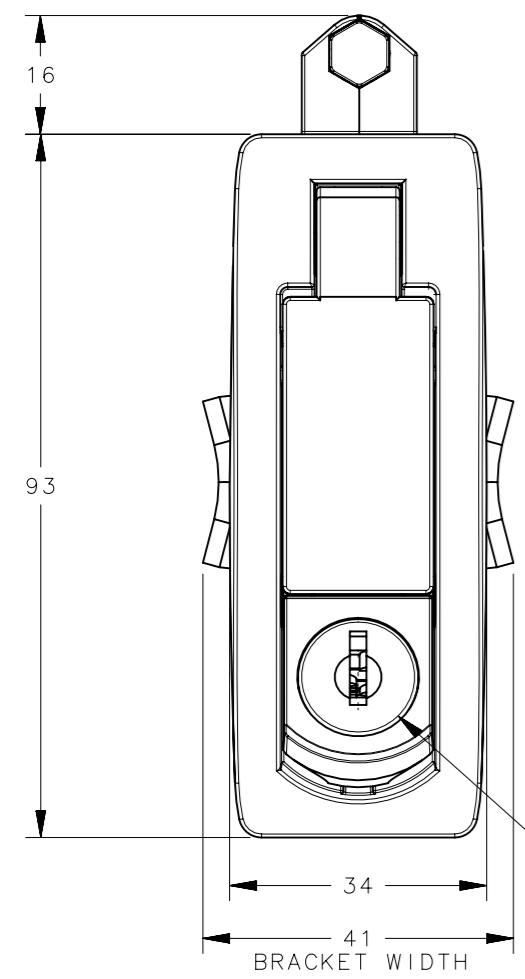

NOTES:

- A. MATERIAL AND FINISH
- HOUSING, HANDLE, LOCK PLUG AND TRIGGER: DIE CAST ZINC, SEE ASSEMBLY PART NUMBER TABLE.
 - LEVER AND CRANK: DIE CAST ZINC, ZINC PLATE.
 - ADJUSTING SCREW, MOUNTING BRACKET, MOUNTING SCREW AND JAM NUT: STEEL, ZINC PLATE.
 - GASKET: NEOPRENE, NATURAL.
 - O-RING: RUBBER, NATURAL.
 - TORSION SPRING: STAINLESS STEEL, NATURAL.
 - U-SPRING: STAINLESS STEEL, PASSIVATED.
 - KEY: BRASS, NICKEL PLATED.
- B. LATCH INSTALLATION:
- PLACE GASKET UNDER LIP OF HOUSING AND PLACE LATCH INTO PANEL PREP.
 - INSERT MOUNTING SCREW INTO MOUNTING BRACKET AND SCREW INTO HOUSING. MOUNTING SCREW IS AN M5 SCREW. USE LONGER SCREWS (NOT SUPPLIED) FOR THICKER DOORS. MAXIMUM MOUNTING BOLT TORQUE 4.5 N.m (30 lbf.in).
 - ADJUST ADJUSTING SCREW TO REQUIRED GRIP AND TIGHTEN JAM NUT. MAXIMUM JAM NUT TORQUE 4 N.m (35.4 lbf.in).
- C. LOCK PLUG INSTALLATION:
- POSITION LOCK PLUG AND ORIENT RETAINING WAFER (LAST WAFER LOCATED AT THE BOTTOM OF LOCK) AT THE 9 O'CLOCK POSITION AND INSERT INTO THE TRIGGER.
 - BE SURE THE LOCK PLUG IS FULLY SEATED AGAINST THE TRIGGER.

TRIGGER OPTION	ASSEMBLY PART NUMBER		TRIGGER OPTION	ASSEMBLY PART NUMBER	
	BLACK POWDER COATED	TEXTURED CHROME FINISH		BLACK POWDER COATED	TEXTURED CHROME FINISH
NON LOCKING (RAISED)	C2-43-15	C2-43-11	KEY LOCKING	C2-43-25	C2-43-21
			4 mm HEX	C2-43-45	C2-43-41
NON LOCKING (FLUSH)	C2-43-35	C2-43-31	8 mm HEX	C2-43-155	C2-43-151
			SLOT HEAD	C2-43-165	C2-43-161
RAILWAY STANDARD	C2-43-145	C2-43-141	No.2 PHILLIPS	C2-43-105	C2-43-101
			WITHOUT LOCK PLUG	C2-43-135	C2-43-131

THIRD ANGLE PROJECTION

MILLIMETERS [IN]

TOLERANCES UNLESS OTHERWISE NOTED

ALL DIMENSIONS WITHOUT TOLERANCES ARE FOR REFERENCE ONLY.

PER ASME Y14.5M-1994

southco[®]
CONNECT • CREATE • INNOVATE

DESCRIPTION: SEALED C2 LEVER LATCH ASSEMBLY LOCKING TRIGGER

SIZE: A3 SYSTEM: NX DWG NO.: J-C2-43

DRAWN BY: JQ DATE: 07MAY2014 SCALE: 1:1 SHEET: 1 OF 1