

DRAWING NUMBER		SCALE		CHKD		DATE		DRAWN		SOUTHCO PART N°		LION PART N°		"U"		"L"		"F"		"T"	
J-85-17-16-1		N.P.S.		AK		7-1-58		ESK		85-15-060-16		5-RA-60		.165		.320		.505		.729	
										85-15-080-16		5-RA-80		.185		.340		.525		.749	
										85-15-100-16		5-RA-100		.205		.360		.545		.769	
										85-15-120-16		5-RA-120		.225		.380		.565		.789	
										85-15-140-16		5-RA-140		.245		.400		.585		.809	
										85-15-160-16		5-RA-160		.265		.420		.605		.829	
										85-15-180-16		5-RA-180		.285		.440		.625		.849	
										85-15-200-16		5-RA-200		.305		.460		.645		.869	
										85-15-220-16		5-RA-220		.325		.480		.665		.889	
										85-15-240-16		5-RA-240		.345		.500		.685		.909	
										85-15-260-16		5-RA-260		.365		.520		.705		.929	
										85-15-280-16		5-RA-280		.385		.540		.725		.949	
										85-15-300-16		5-RA-300		.405		.560		.745		.969	
										85-15-320-16		5-RA-320		.425		.580		.765		.989	
										85-15-340-16		5-RA-340		.445		.600		.785		1.009	
										85-15-360-16		5-RA-360		.465		.620		.805		1.029	
										85-15-380-16		5-RA-380		.485		.640		.825		1.049	
										85-15-400-16		5-RA-400		.505		.660		.845		1.069	
										85-15-420-16		5-RA-420		.525		.680		.865		1.089	
										85-15-440-16		5-RA-440		.545		.700		.885		1.109	
										85-15-460-16		5-RA-460		.565		.720		.905		1.129	
										85-15-480-16		5-RA-480		.585		.740		.925		1.149	
										85-15-500-16		5-RA-500		.605		.760		.945		1.169	
										85-15-520-16		5-RA-520		.625		.780		.965		1.189	
										85-15-540-16		5-RA-540		.645		.800		.985		1.209	
										85-15-560-16		5-RA-560		.665		.820		1.005		1.229	
										85-15-580-16		5-RA-580		.685		.840		1.025		1.249	
										85-15-600-16		5-RA-600		.705		.860		1.045		1.269	
										85-15-620-16		5-RA-620		.725		.880		1.065		1.289	
										85-15-640-16		5-RA-640		.745		.900		1.085		1.309	
										85-15-660-16		5-RA-660		.765		.920		1.105		1.329	
										85-15-680-16		5-RA-680		.785		.940		1.125		1.349	
										85-15-700-16		5-RA-700		.805		.960		1.145		1.369	
										85-15-720-16		5-RA-720		.825		.980		1.165		1.389	
										85-15-740-16		5-RA-740		.845		1.000		1.185		1.409	
										85-15-760-16		5-RA-760		.865		1.020		1.205		1.429	
										85-15-780-16		5-RA-780		.885		1.040		1.225		1.449	
										85-15-800-16		5-RA-800		.905		1.060		1.245		1.469	
										85-15-820-16		5-RA-820		.925		1.080		1.265		1.489	
										85-15-840-16		5-RA-840		.945		1.100		1.285		1.509	
										85-15-860-16		5-RA-860		.965		1.120		1.305		1.529	
										85-15-880-16		5-RA-880		.985		1.140		1.325		1.549	
										85-15-900-16		5-RA-900		1.005		1.160		1.345		1.569	
										85-15-920-16		5-RA-920		1.025		1.180		1.365		1.589	
										85-15-940-16		5-RA-940		1.045		1.200		1.385		1.609	
										85-15-960-16		5-RA-960		1.065		1.220		1.405		1.629	
										85-15-980-16		5-RA-980		1.085		1.240		1.425		1.649	
										85-15-1000-16		5-RA-1000		1.105		1.260		1.445		1.669	

REV. M-06AUG93 MFE PRN: S-99-I-N-1
 REV. N 25NOV96 SWD PRN: S-1-06A

SOUTHCO No. 85 BAIL HEAD STUD

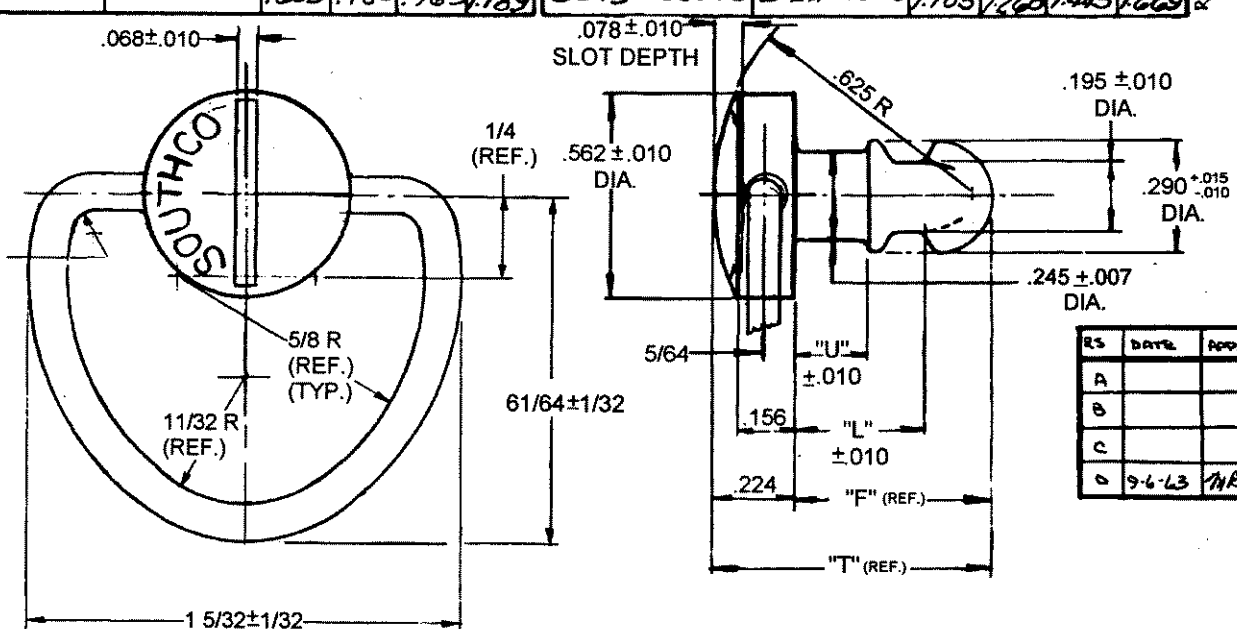

RS	DATE	APP.
A		
B		
C		
D	9-6-83	TRD

MATERIAL-STEEL, CASE HARDENED
 FINISH- ZINC PLATE, CHROMATE PLUS SEALER.

TOLERANCE UNLESS OTHERWISE NOTED IS $\pm .020$.

PROPRIETARY ITEM - EXCEPT FOR USES EXPRESSLY GRANTED IN WRITING, INFORMATION DISCLOSED HEREON IS CONFIDENTIAL AND ALL RIGHTS, PATENT AND OTHERWISE, ARE RESERVED BY SOUTHCO, INC.