

southco

PROPRIETARY ITEM - EXCEPT FOR USES EXPRESSLY GRANTED IN WRITING INFORMATION DISCLOSED HEREON IS CONFIDENTIAL AND ALL RIGHTS PATENT AND OTHERWISE ARE RESERVED BY SOUTHCO, INC.

SOUTHCO No.82 STUD FASTENER, OVAL HEAD

DATE	DRAWN	CHKD	SCALE
11JUN99	MDM	CHW	2 : 1

DRAWING NUMBER
J-82-11-1

REV.	DATE	DRAWN	REVISION	PART No.	MATERIAL	FINISH
A	20JUL99	MDM/MLG	PRN: 82-456A	SEE TABLE	SEE NOTE A	SEE NOTE B
B	19MAR07	DAW/RLR	PRN: P2007-0398			

INCH DIMENSIONS
DIMENSIONS WITHOUT TOLERANCES ARE FOR REFERENCE ONLY.



NOTES

A- MATERIAL: XX = -16, -52, -31, -17: 1008 STEEL, CASE HARDENED
= -20, -43 STAINLESS STEEL

B- FINISH: XX = -16: ZINC PLATE, CHROMATE, PLUS SEALER
= -17: ZINC PLATE, YELLOW CHROMATE
= -20: PASSIVATED
= -31: BLACK OXIDE
= -43: NATURAL
= -52: BLACK ORGANIC COATING

PART No.	U	L	F
82-11-040-XX	.067	.185	.335
82-060-	.087	.205	.355
82-080-	.107	.225	.375
82-100-	.127	.245	.395
82-120-	.147	.265	.415
82-140-	.167	.285	.435
82-160-	.187	.305	.455
82-180-	.207	.325	.475
82-200-	.227	.345	.495
82-220-	.247	.365	.515
82-240-	.267	.385	.535
82-260-	.287	.405	.555
82-280-	.307	.425	.575
82-300-	.327	.445	.595
82-320-	.347	.465	.615
82-340-	.367	.485	.635
82-360-	.387	.505	.655
82-380-	.407	.525	.675
82-400-	.427	.545	.695
82-420-	.447	.565	.715
82-440-	.467	.585	.735
82-460-	.487	.605	.755
82-480-	.507	.625	.775
82-500-	.527	.645	.795
82-11-520-XX	.547	.665	.815

PART No.	U	L	F
82-11-540-XX	.567	.685	.835
82-560-	.587	.705	.855
82-580-	.607	.725	.875
82-600-	.627	.745	.895
82-620-	.647	.765	.915
82-640-	.667	.785	.935
82-660-	.687	.805	.955
82-680-	.707	.825	.975
82-700-	.727	.845	.995
82-720-	.747	.865	1.015
82-740-	.767	.885	1.035
82-760-	.787	.905	1.055
82-780-	.807	.925	1.075
82-800-	.827	.945	1.095
82-820-	.847	.965	1.115
82-840-	.867	.985	1.135
82-860-	.887	1.005	1.155
82-880-	.907	1.025	1.175
82-900-	.927	1.045	1.195
82-920-	.947	1.065	1.215
82-940-	.967	1.085	1.235
82-960-	.987	1.105	1.255
82-980-	1.007	1.125	1.275
82-11-1000-XX	1.027	1.145	1.295

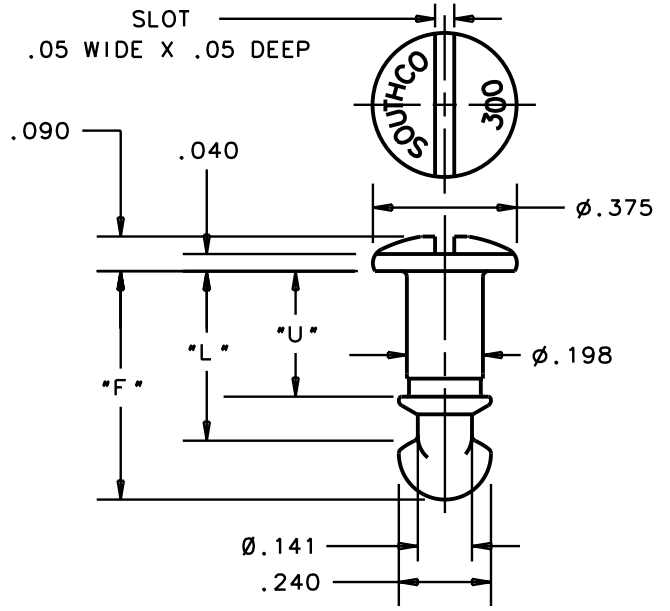

(PART No. 82-11-300-XX SHOWN)

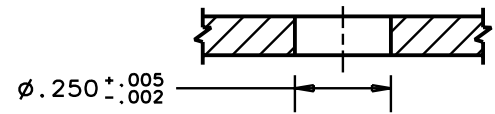

SUGGESTED PANEL PREPARATION