



SOUTHCO No. 82 - FLUSH HEAD STUD

| DATE | DRAWN | CHKD | SCALE | DRAWING NUMBER |
|----------|-------|------|--------|----------------|
| 11-30-88 | ESK | | N.T.S. | J-82-54-20-1 |

| SOUTHCO PART No. | U | L | F | SOUTHCO PART No. | U | L | F |
|------------------|------|------|------|------------------|-------|-------|-------|
| 82-14-080-20 | .107 | .225 | .375 | 82-14-520-20 | .547 | .665 | .815 |
| ↖ 100 ↗ | .127 | .245 | .395 | ↖ 540 ↗ | .567 | .685 | .835 |
| 120 | .147 | .265 | .415 | 560 | .587 | .705 | .855 |
| 140 | .167 | .285 | .435 | 580 | .607 | .725 | .875 |
| 160 | .187 | .305 | .455 | 600 | .627 | .745 | .895 |
| 180 | .207 | .325 | .475 | 620 | .647 | .765 | .915 |
| 200 | .227 | .345 | .495 | 640 | .667 | .785 | .935 |
| 220 | .247 | .365 | .515 | 660 | .687 | .805 | .955 |
| 240 | .267 | .385 | .535 | 680 | .707 | .825 | .975 |
| 260 | .287 | .405 | .555 | 700 | .727 | .845 | .995 |
| 280 | .307 | .425 | .575 | 720 | .747 | .865 | 1.015 |
| 300 | .327 | .445 | .595 | 740 | .767 | .885 | 1.035 |
| 320 | .347 | .465 | .615 | 760 | .787 | .905 | 1.055 |
| 340 | .367 | .485 | .635 | 780 | .807 | .925 | 1.075 |
| 360 | .387 | .505 | .655 | 800 | .827 | .945 | 1.095 |
| 380 | .407 | .525 | .675 | 820 | .847 | .965 | 1.115 |
| 400 | .427 | .545 | .695 | 840 | .867 | .985 | 1.135 |
| 420 | .447 | .565 | .715 | 860 | .887 | 1.005 | 1.155 |
| 440 | .467 | .585 | .735 | 880 | .907 | 1.025 | 1.175 |
| 460 | .487 | .605 | .755 | 900 | .927 | 1.045 | 1.195 |
| ↖ 480 ↗ | .507 | .625 | .775 | 920 | .947 | 1.065 | 1.215 |
| 82-14-500-20 | .527 | .645 | .795 | 940 | .967 | 1.085 | 1.235 |
| | | | | 960 | .987 | 1.105 | 1.255 |
| | | | | ↖ 980 ↗ | 1.007 | 1.125 | 1.275 |
| | | | | 82-14-1000-20 | 1.027 | 1.145 | 1.295 |

DRAWING NUMBER
J-82-54-20-1

MATERIAL ~ STAINLESS STEEL
FINISH ~ PASSIVATE

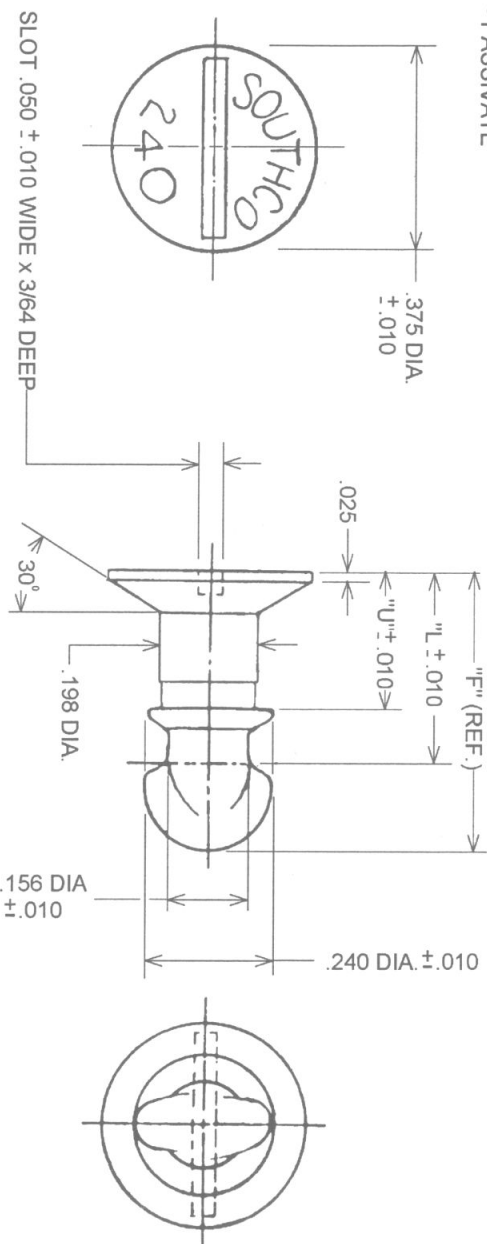

PROPRIETARY ITEM ~ EXCEPT FOR USE EXPRESSLY
GRANTED IN WRITING. INFORMATION DISCLOSED
HEREON IS CONFIDENTIAL AND ALL RIGHTS, PATENT
AND OTHERWISE, ARE RESERVED BY SOUTHCO, INC.

| REV. | DATE | DRAWN | REVISION |
|------|-----------|-------|-------------|
| B | 14JUL2000 | JCK | PRN: 82-472 |
| A | 05MAR93 | JC | PRN: S-1-03 |