

6

5

4

3

2

1

REVISION HISTORY			
REV	DATE	BY	DESCRIPTION
D	09SEP2015	CMS/NJF	PRN: P2015-1255

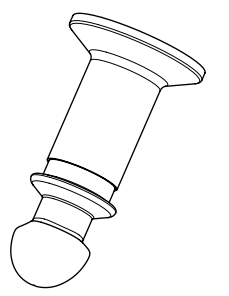
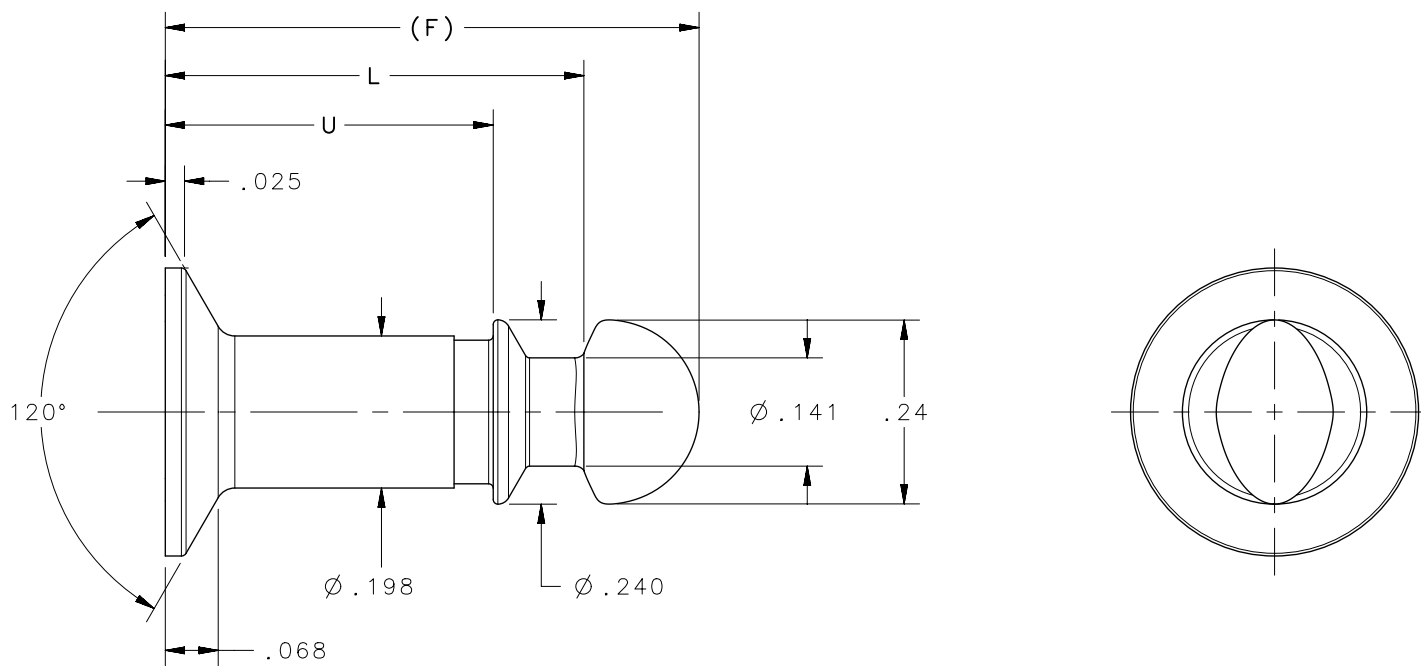
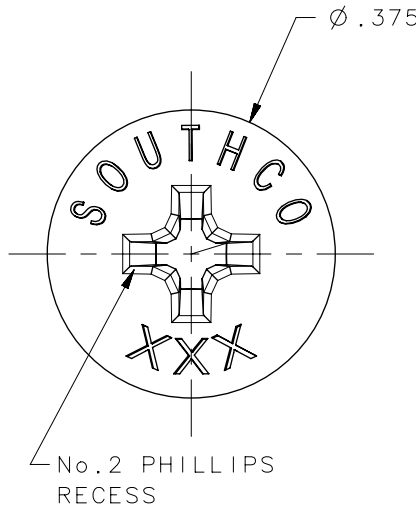

SCALE 2:1

82-28-540-XX	.567	.685	.835	-	-	-	-
82-28-520-XX	.547	.665	.815	82-28-1000-XX	1.027	1.145	1.295
82-28-500-XX	.527	.645	.795	82-28-980-XX	1.007	1.125	1.275
82-28-480-XX	.507	.625	.775	82-28-960-XX	.987	1.105	1.255
82-28-460-XX	.487	.605	.755	82-28-940-XX	.967	1.085	1.235
82-28-440-XX	.467	.585	.735	82-28-920-XX	.947	1.065	1.215
82-28-420-XX	.447	.565	.715	82-28-900-XX	.927	1.045	1.195
82-28-400-XX	.427	.545	.695	82-28-880-XX	.907	1.025	1.175
82-28-380-XX	.407	.525	.675	82-28-860-XX	.887	1.005	1.155
82-28-360-XX	.387	.505	.655	82-28-840-XX	.867	.985	1.135
82-28-340-XX	.367	.485	.635	82-28-820-XX	.847	.965	1.115
82-28-320-XX	.347	.465	.615	82-28-800-XX	.827	.945	1.095
82-28-300-XX	.327	.445	.595	82-28-780-XX	.807	.925	1.075
82-28-280-XX	.307	.425	.575	82-28-760-XX	.787	.905	1.055
82-28-260-XX	.287	.405	.555	82-28-740-XX	.767	.885	1.035
82-28-240-XX	.267	.385	.535	82-28-720-XX	.747	.865	1.015
82-28-220-XX	.247	.365	.515	82-28-700-XX	.727	.845	.995
82-28-200-XX	.227	.345	.495	82-28-680-XX	.707	.825	.975
82-28-180-XX	.207	.325	.475	82-28-660-XX	.687	.805	.955
82-28-160-XX	.187	.305	.455	82-28-640-XX	.667	.785	.935
82-28-140-XX	.167	.285	.435	82-28-620-XX	.647	.765	.915
82-28-120-XX	.147	.265	.415	82-28-600-XX	.627	.745	.895
82-28-100-XX	.127	.245	.395	82-28-580-XX	.607	.725	.875
82-28-080-XX	.107	.225	.375	82-28-560-XX	.587	.705	.855
SOUTHCO PART NUMBER	*U*	*L*	*F*	SOUTHCO PART NUMBER	*U*	*L*	*F*

NOTES:-

- 1. MATERIAL: XX = -13, -16, -17, -31, -52: STEEL, CASE HARDENED
= -20, -44: STAINLESS STEEL
- 2. FINISH: XX = -13: NATURAL
= -16: ZINC PLATE, CHROMATE, PLUS SEALER
= -17: ZINC PLATE, YELLOW CHROMATE
= -20: PASSIVATED
= -31: BLACK OXIDE
= -44: BLACK OXIDE, SEMI-GLOSS
= -52: PLATED, ZINC-NICKEL BLACK

THIRD ANGLE PROJECTION				
	INCHES [MM]		DESCRIPTION	
TOLERANCES UNLESS OTHERWISE NOTED		No.82 - FLUSH HEAD STUD		
X° ±2°		PHILLIPS RECESS		
X/X ±1/32		SIZE	DWG NO.	
.XX ±.015		B	NX	
.XXX ±.010		DATE	J-82-28-52	
PER ASME Y14.5M-1994		DRAWN BY	SCALE 4:1	
		RLR/MDY	SHEET 1 OF 1	
		DATE 07SEP2004		

6

5

4

3

2

1