

**southco**

PROPRIETARY ITEM - EXCEPT FOR USES EXPRESSLY GRANTED IN WRITING, INFORMATION DISCLOSED HEREON IS CONFIDENTIAL AND ALL RIGHTS, PATENT AND OTHERWISE ARE RESERVED BY SOUTHCO, INC.

No. 62 43-SERIES  
TOOL SECURED LATCH ASSEMBLY

DATE  
08JUN94

DRAWN  
BMC

CHKD  
1:1

SCALE  
1:1

DRAWING NUMBER  
J-62-47

REV. DATE  
1 17SEP2012

DRAWN  
MJS/MSR

PRN: P2012-1251

REVISION

ALL DIMENSIONS ARE IN MILLIMETERS. ALL DIMENSIONS WITHOUT TOLERANCES ARE REFERENCE.

A3 PAPER SIZE  
THIRD ANGLE PROJECTION

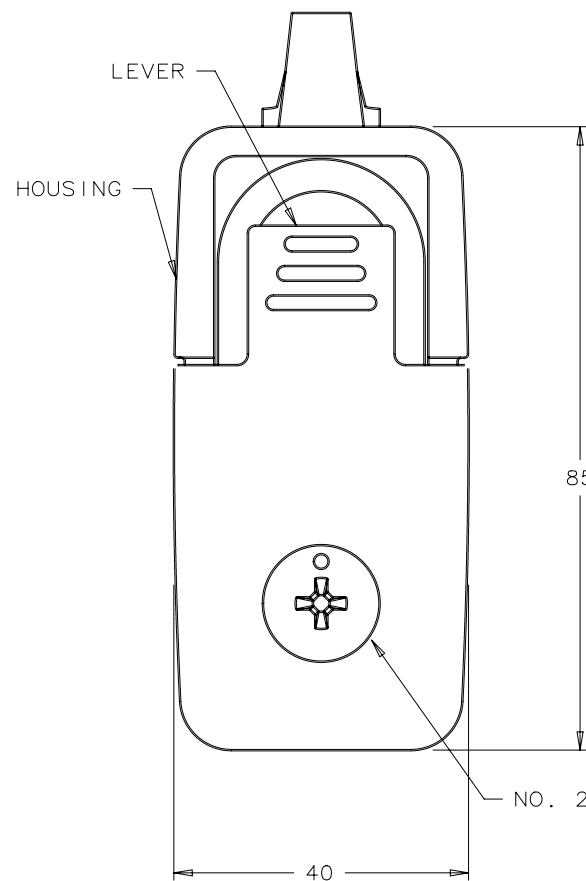

GRIP RANGE		INDIVIDUALLY PACKAGED ASSEMBLY PART NUMBER					SILVER METALLIC POLYESTER URETHANE POWDER COATED
MIN-MAX	MIN-MAX	TEXTURED CHROME	POLISHED CHROME	WHITE POWDER COATED	BLACK POWDER COATED		
6 - 16	56 - 66	62-43-101-2	62-43-111-2	62-43-141-2	62-43-151-2	62-43-161-2	
16 - 26	46 - 56	62-43-201-2	62-43-211-2	62-43-241-2	62-43-251-2	62-43-261-2	
26 - 36	36 - 46	62-43-301-2	62-43-311-2	62-43-341-2	62-43-351-2	62-43-361-2	

GRIP RANGE		BULK LAYER PACKED ASSEMBLY PART NUMBER					SILVER METALLIC POLYESTER URETHANE POWDER COATED
MIN-MAX	MIN-MAX	TEXTURED CHROME	POLISHED CHROME	WHITE POWDER COATED	BLACK POWDER COATED		
6 - 16	56 - 66	62-43-101-3	62-43-111-3	62-43-141-3	62-43-151-3	62-43-161-3	
16 - 26	46 - 56	62-43-201-3	62-43-211-3	62-43-241-3	62-43-251-3	62-43-261-3	
26 - 36	36 - 46	62-43-301-3	62-43-311-3	62-43-341-3	62-43-351-3	62-43-361-3	

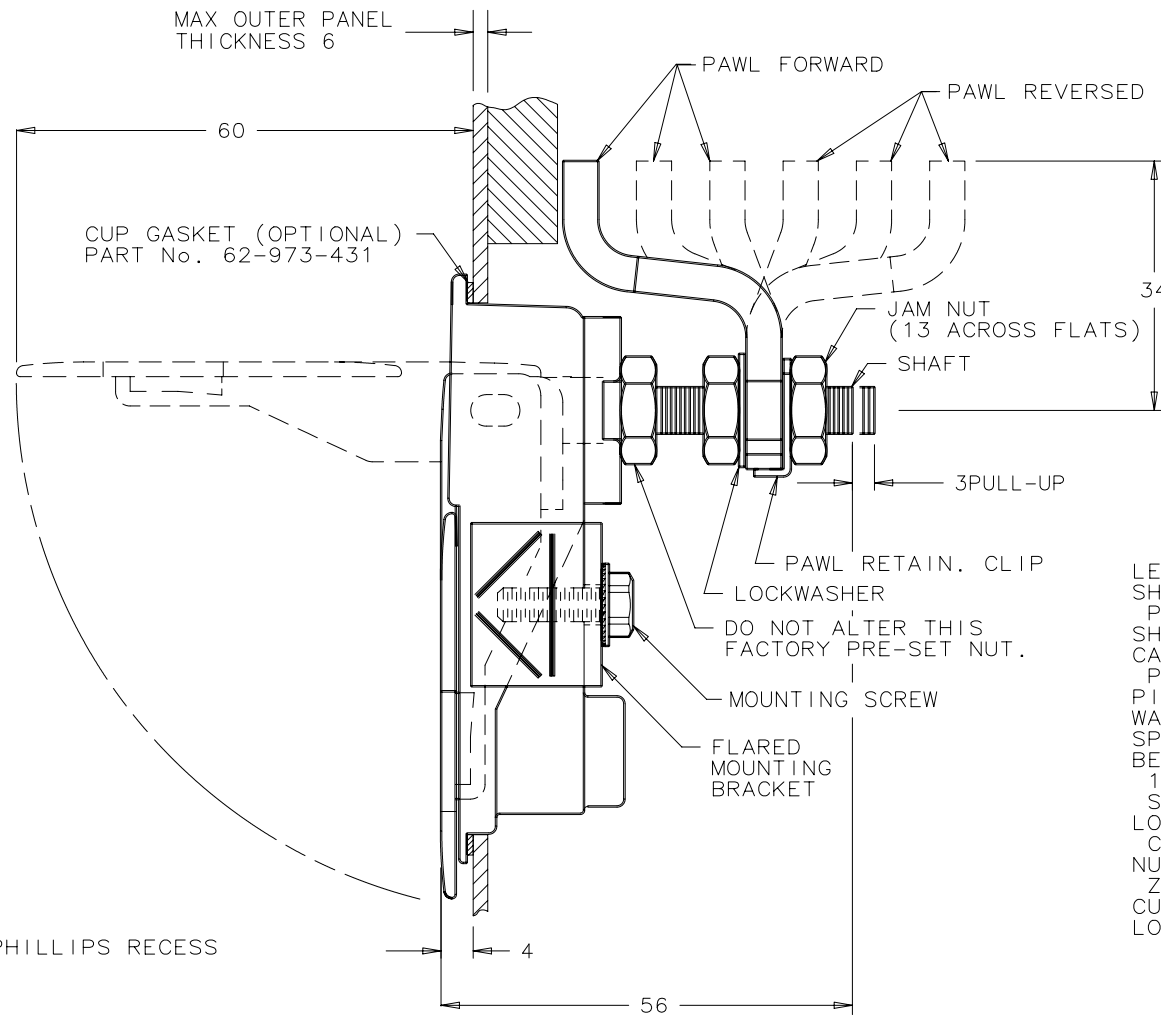

- NOTES**
1. THREAD SIZE OF SHAFT IS M8 AND THE MOUNTING SCREW IS M5.
  2. THICKER PANELS REQUIRE A LONGER MOUNTING SCREW (NOT SUPPLIED).
  3. ASSEMBLE AS SHOWN AND ROTATE PAWL TO THE DESIRED LATCHING POSITION.
  4. PAWL SHOULD BE ADJUSTED TO GRIP MEASUREMENT WITH THE DOOR OPEN AND THE LEVER IN THE LATCHED POSITION. USE TWO WRENCHES TO TIGHTEN JAM NUTS.
  5. FOR MOST EFFECTIVE ENVIRONMENTAL SEALING, USE A CUP GASKET AND SEAL THE MOUNTING SCREW THREADS.

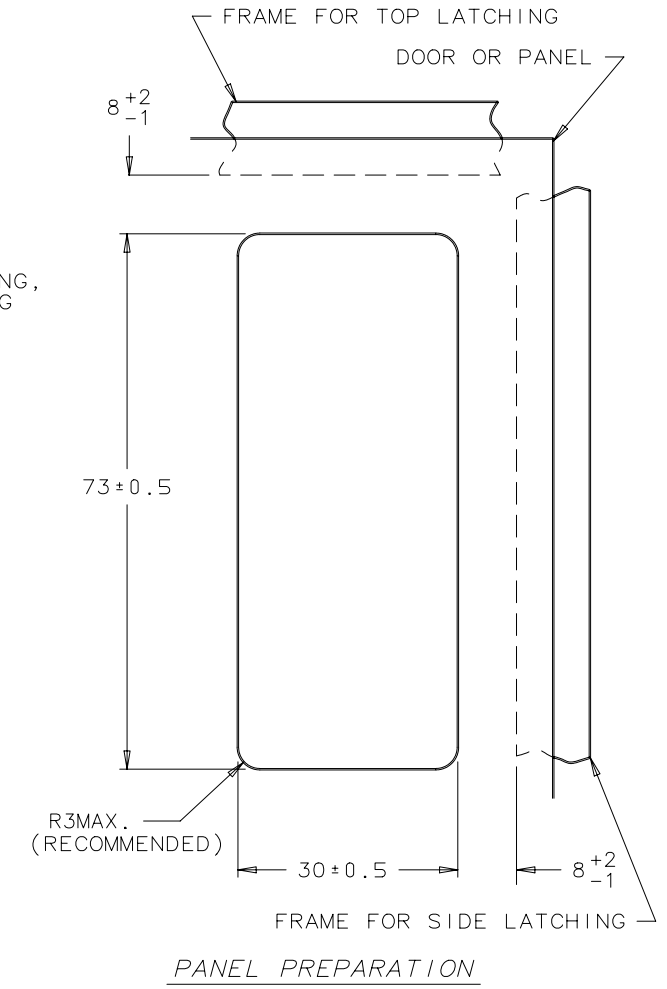

**MATERIAL AND FINISH**

LEVER, HOUSING AND LOCK PLUG: DIE CAST ZINC, SEE TABLE.  
 SHAFT: STEEL, ZINC ALLOY PLATE BRIGHT CHROMATE, PLUS SEALER OR WITH BLACK ORGANIC COATING.  
 SHAFT O-RING: SYNTHETIC RUBBER, NATURAL.  
 CAM: 1010 STEEL, ZINC ALLOY PLATE BRIGHT CHROMATE, PLUS SEALER OR WITH BLACK ORGANIC COATING.  
 PIN: 303 STAINLESS STEEL, PASSIVATED.  
 WASHER: 1010 STEEL, ZINC PLATED BRIGHT OR BLACK OXIDE.  
 SPRINGS: 302 STAINLESS STEEL, PASSIVATED.  
 BEARING WASHER, PAWL, PAWL RETAINING CLIP & BRACKET: 1010 STEEL, ZINC ALLOY PLATE BRIGHT CHROMATE, PLUS SEALER.  
 LOCKWASHER: SPRING STEEL, ZINC ALLOY PLATE BRIGHT CHROMATE, PLUS SEALER.  
 NUTS & MOUNTING SCREW: LOW CARBON STEEL, ZINC ALLOY PLATE BRIGHT CHROMATE, PLUS SEALER.  
 CUP GASKET: SYNTHETIC RUBBER, NATURAL.  
 LOCK PLATE: STAINLESS STEEL, PASSIVATED OR BLACK OXIDE.