

NOTES:

- A- THREAD SIZE OF SLEEVE IS 5/8-24 AND THE SHAFT IS AN M8.
- B- ASSEMBLE AS SHOWN AND ROTATE PAWL TO THE DESIRED LATCHING POSITION.
- C- PAWL SHOULD BE ADJUSTED TO GRIP MEASUREMENT WITH THE DOOR OPEN AND THE HANDLE IN THE LATCHED POSITION. USE TWO WRENCHES TO TIGHTEN.
- D- MATERIAL AND FINISH:  
 HANDLE AND SLEEVE: DIE CAST ZINC, SEE TABLE.  
 WASHER AND SPRING: 302 STAINLESS STEEL, PASSIVATED.  
 O-RING: BUNA-N RUBBER, NATURAL.  
 SHAFT AND LONG PIN: 303 STAINLESS STEEL, PASSIVATED OR PASSIVATED WITH BLACK ORGANIC COATING.  
 BUSHING: 303 STAINLESS STEEL, BLACK OXIDE  
  
 PAWL POSITIONING PIN: 303 STAINLESS STEEL, NATURAL OR BLACK ORGANIC COATING.  
 PAWL AND PAWL RETAINING CLIP: 1010 STEEL, ZINC PLATE PLUS SEALER.  
 GASKET: FIBRE, NATURAL.  
 LOCKWASHERS: SPRING STEEL, ZINC PLATE PLUS SEALER.  
 JAM NUTS: LOW CARBON STEEL, ZINC PLATE, CHROMATE PLUS SEALER.  
 MOUNTING NUT: DIE CAST ZINC, ZINC PLATE, CHROMATE PLUS SEALER.

GRIP		ASSEMBLY PART NUMBER TABLE			
MIN	MAX	POLISHED CHROME	BRUSHED CHROME	BLACK POWDER COATED	SATIN SILVER POLYESTER POWDER COATED
0	5	62-30-11	62-30-12	62-30-15	62-30-17
5	15	62-30-21	62-30-22	62-30-25	62-30-27
15	25	62-30-31	62-30-32	62-30-35	62-30-37
25	35	62-30-31	62-30-32	62-30-35	62-30-37
35	45	62-30-21	62-30-22	62-30-25	62-30-27
45	55	62-30-11	62-30-12	62-30-15	62-30-17

NOTE: FOR HANDLES WITHOUT LETTERING, ADD -1 TO THE END OF THE PART NUMBER. (EXAMPLE: 62-30-21-1)

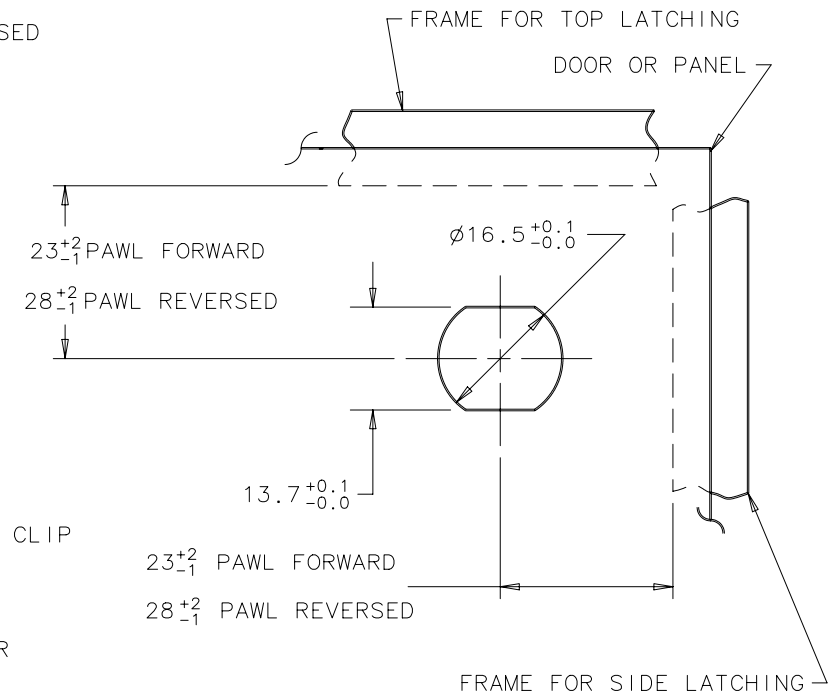
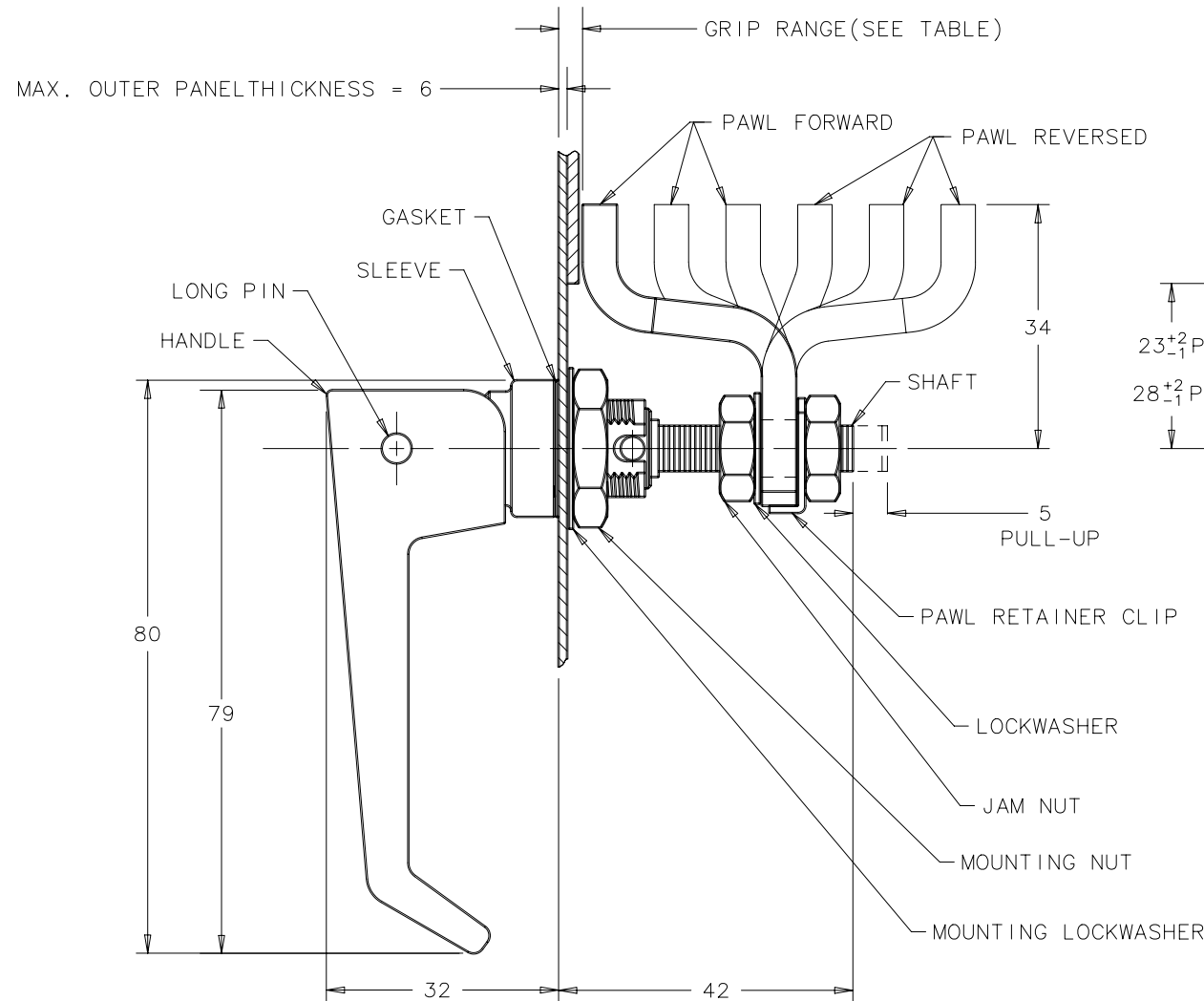
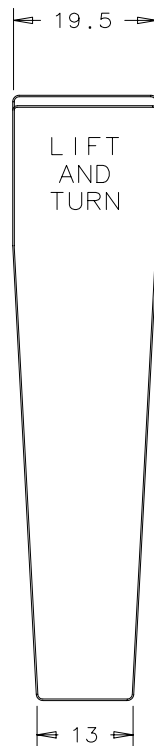

PANEL PREPARATION