

REV	DATE	DRAWN/CHKD	DESCRIPTION	ITEM	PART NUMBER	MATERIAL	FINISH	
L	17MAY2003	AJH/MJS	PRN: P2003-0382	ASSEMBLY	61-1-7-0			
M	12APR2005	BRP/RLR	PRN: 2005-0589	RETAINER CLIP		SPRING STEEL	ZINC FLAKE COATING	
				PAWL		1010 STEEL	ZINC PLATE, CHROMATE PLUS SEALER	
				HANDLE		1010 STEEL	BRIGHT NICKEL PLATED	
				SHAFT		1008 STEEL	BRIGHT NICKEL PLATED	
				TRIM WASHER		LOW CARBON STEEL	BRIGHT NICKEL PLATED	
				SETSCREW		HARDENED STEEL	ZINC PLATE PLUS CHROMATE DIP, BRIGHT	

INCHES

ALL DIMENSIONS WITHOUT TOLERANCES ARE FOR REFERENCE ONLY.

THIRD ANGLE PROJECTION

B PAPER SIZE

NOTES:

- A. LATCH SHIPPED UNASSEMBLED.
- B. THESE ASSEMBLIES ARE NON-REPAIRABLE ITEMS AND COMPONENTS ARE NOT AVAILABLE AS REPLACEMENT OR REPAIR PARTS.

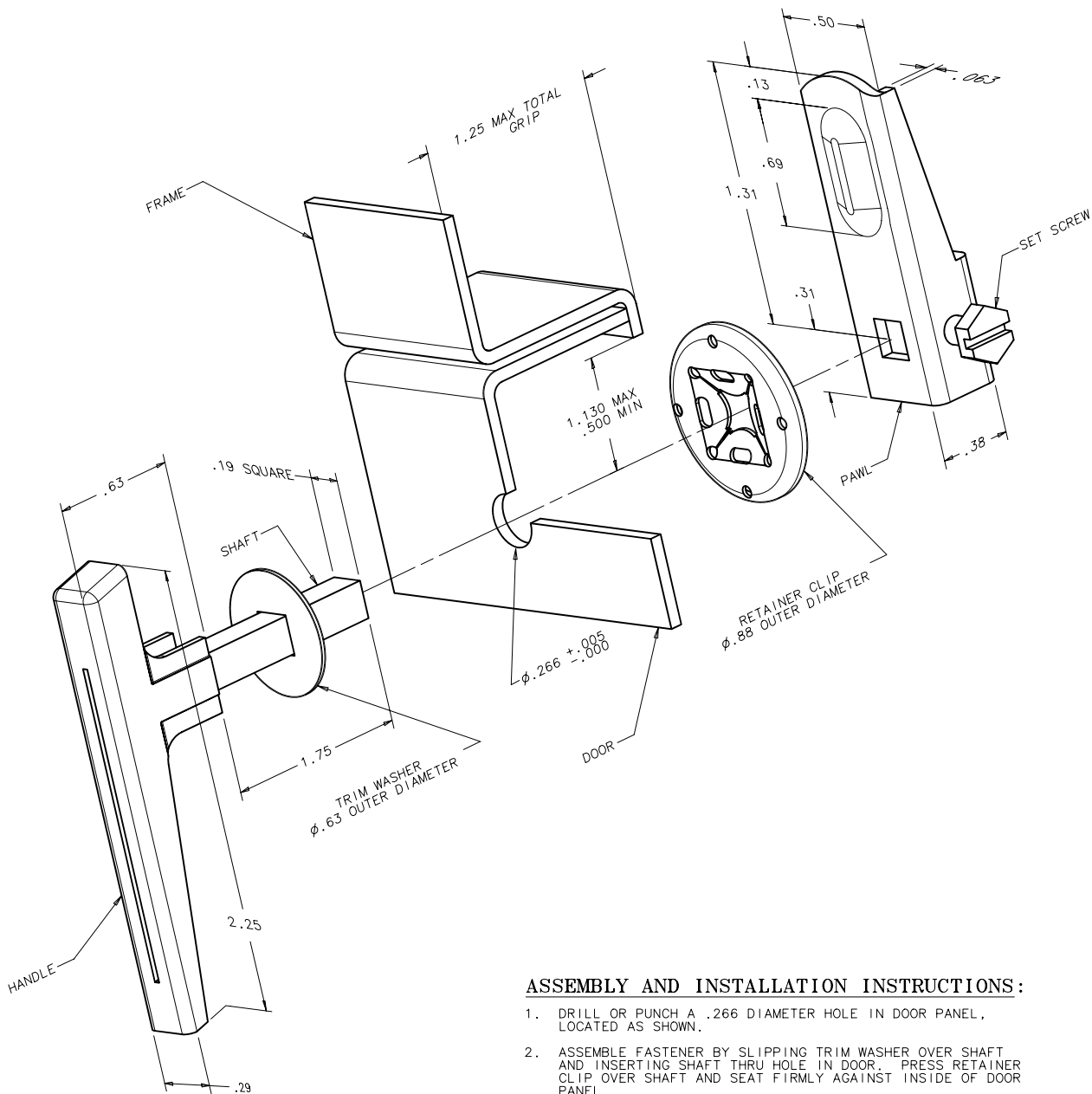

ASSEMBLY AND INSTALLATION INSTRUCTIONS:

1. DRILL OR PUNCH A .266 DIAMETER HOLE IN DOOR PANEL, LOCATED AS SHOWN.
2. ASSEMBLE FASTENER BY SLIPPING TRIM WASHER OVER SHAFT AND INSERTING SHAFT THRU HOLE IN DOOR. PRESS RETAINER CLIP OVER SHAFT AND SEAT FIRMLY AGAINST INSIDE OF DOOR PANEL.
3. ADJUST PAWL TO DESIRED GRIP POSITION AND TIGHTEN SETSCREW.