

REVISION HISTORY			
REV	DATE	BY	DESCRIPTION
A	16MAR2015	BGL/CMS	PRN: P2015-0516

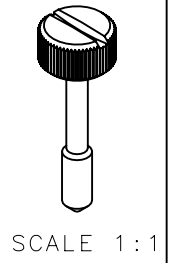
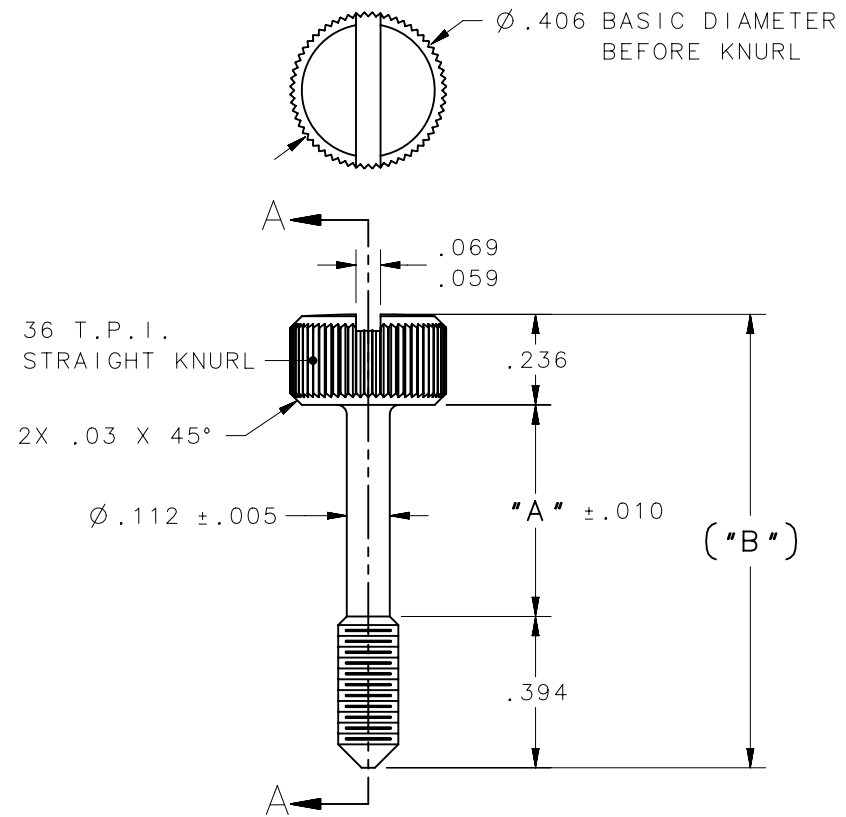

SLOTTED SCREW
 PART NUMBER SHOWN 58-94-314-20

58-84-314-XX	58-74-314-XX	.551	1.18	SEE NOTE A
58-84-316-XX	58-74-316-XX	.630	1.26	
58-84-318-XX	58-74-318-XX	.709	1.34	
58-84-320-XX	58-74-320-XX	.787	1.42	
58-84-322-XX	58-74-322-XX	.866	1.50	
58-84-324-XX	58-74-324-XX	.945	1.58	
58-84-326-XX	58-74-326-XX	1.024	1.65	
NON-SLOTTED HEAD	SLOTTED HEAD	"A"	("B")	MATERIAL AND FINISH

NOTE:
 A. MATERIAL AND FINISH:
 -24 = STAINLESS STEEL, PASSIVATE.
 -26 = STAINLESS STEEL, PASSIVATED PLUS BLACK ORGANIC COATING.

THIRD ANGLE PROJECTION		 CONNECT • CREATE • INNOVATE	
INCHES [MM]			
TOLERANCES UNLESS OTHERWISE NOTED		DESCRIPTION	
ALL DIMENSIONS WITHOUT TOLERANCES ARE FOR REFERENCE ONLY.		SOUTHCO No. 58 SCREW FASTNER M4 X 0.7 THREAD WITH 13/32 DIA. HEAD	
PROPRIETARY ITEM <small>EXCEPT FOR USES EXPRESSLY GRANTED IN WRITING, INFORMATION DISCLOSED HEREON IS CONFIDENTIAL AND ALL RIGHTS, PATENT AND OTHERWISE, ARE RESERVED BY SOUTHCO, INC.</small>	PER ASME Y14.5M-1994	SIZE A	SYSTEM NX
		DWG NO. J-58-132	
DRAWN BY JGK	DATE MAR211991	SCALE NTS	SHEET 1 OF 1