

southco®

PROPRIETARY ITEM - EXCEPT FOR USES EXPRESSLY GRANTED IN WRITING INFORMATION DISCLOSED HEREON IS CONFIDENTIAL AND ALL RIGHTS PATENT AND OTHERWISE ARE RESERVED BY SOUTHCO, INC.

52 CAPTIVE SCREW ASSEMBLY FLARE-IN STYLE, SMOOTH HEAD, M3 THREAD

DATE	DRAWN	CHKD	SCALE	DRAWING NUMBER
07FEB2002	AJH	TVA	3:1	J-52-3-11

REV	DATE	DRAWN/CHKD	DESCRIPTION	PART NUMBER	MATERIAL AND FINISH	PANEL THICKNESS		L	Y	P-1	P-2
						MIN	MAX				
A	16APR2002	TVA/AJH	PRN: P2002-0215 (RELEASED)	52-38-11-4	SEE NOTE A	0.8	2.4	1	0.4	0.8	5.3
B	22MAY2002	RJB	PRN: P2002-0301	52-38-13-4	SEE NOTE A	0.8	2.4	1	0.4	2.3	6.9
C	11NOV2003	LTS/MJS	PRN: P2003-1024	52-3A-11-4	SEE NOTE A	0.8	2.4	1	0.4	0.8	5.3
D	23MAY2006	MJS/RLR	PRN: P2006-0726	52-3A-13-4	SEE NOTE A	0.8	2.4	1	0.4	2.3	6.9
E	14JAN2011	MJS/TVA	PRN: P2011-0068								
F	19OCT2017	CMS/CTG	PRN: P2017-2559								

MILLIMETERS

ALL DIMENSIONS WITHOUT TOLERANCES ARE FOR REFERENCE ONLY.

THIRD ANGLE PROJECTION A4 PAPER SIZE

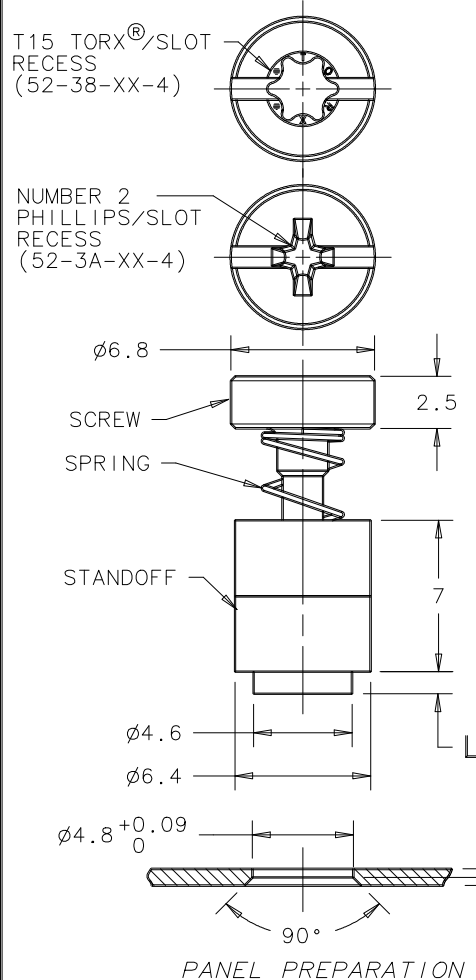

NOTES:

- A. - SCREW: STEEL, HARDENED, ZINC PLATE PLUS SEALER
 - SPRING: 300 SERIES STAINLESS STEEL, PASSIVATED
 - STANDOFF: 6000 SERIES ALUMINUM, NATURAL
- B. INSTALLATION INSTRUCTIONS:
 1. PREPARE THE HOLE IN THE PANEL, COUNTERSINK UNDERSIDE OF THE PANEL AS SHOWN.
 2. PUNCH SURFACE AND INSTALLATION TOOL MUST REMAIN PARALLEL DURING FLARING OF STANDOFF.
 ONLY USE LIGHT PRESSURE TO FLARE STANDOFF. RECOMMENDED LOAD OF 3000N
 3. USE SOUTHCO INSTALLATION TOOL, PART NUMBER 47-104, TO FLARE THIS ASSEMBLY.
- C. TORX® IS A REGISTERED TRADEMARK OF THE CAMCAR DIVISION OF TEXTRON INC.
- D. RECOMMENDED MAXIMUM TIGHTENING TORQUE OF 60 N-cm.
- E. RoHS COMPLIANT.

