



52-SM Captive Screws

Miniature series · Surface Mount Technology (SMT) Style

- For installation to PC Board material utilizing surface mount technology
- Smaller footprint for limited space applications
- Heat treated steel screw for optimum strength

Material and Finish

Screw: Hardened carbon steel, zinc plated, chromate, plus sealer
 Internal spring: 300 series stainless steel, passivated
 Standoff: Steel, Tin plated
 Plug: Silicone rubber

Installation Notes

Visit www.southco.com for additional installation guidelines

Part Number

See table

Recess Styles

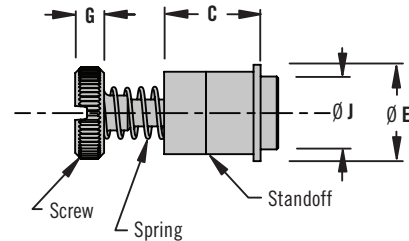
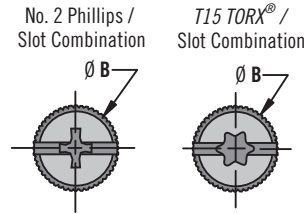

Screw Height and Screw Projection

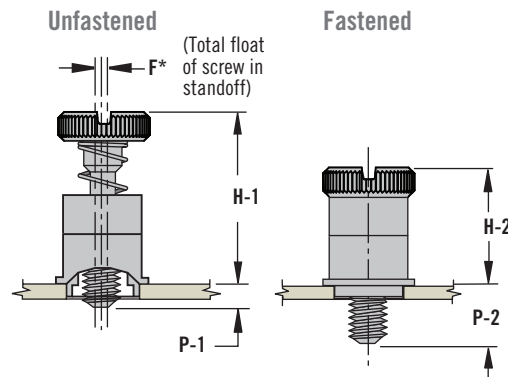

* Value represents float in unfastened position
 Notes: P-1, P-2 Screw Projection measured from the top side of panel

PC Board Preparation

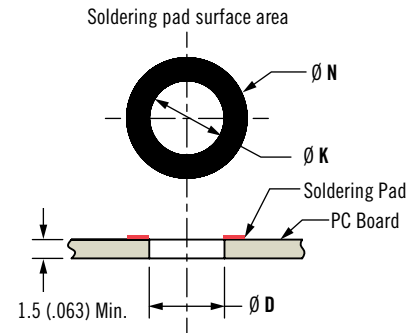

Screw as Shipped in Reel Pack or Tray Pack

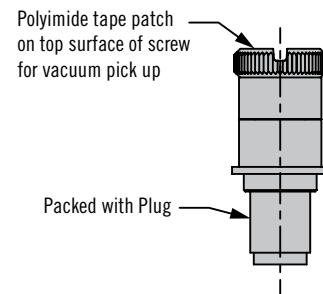

52 Captive Screws Miniature Series - SMT Style

Part Number

Specify Package
 Indicate package option with last digit of the part number

Example

52-SM-1311-K-R: Reel Package (as shown in table)
 52-SM-1311-K-T: Tray Package

Thread Size	Part Number (Reel package shown)				H-1	H-2	P-1	P-2	Ø B Knurled Head	Ø B Smooth Head	Ø J	Ø E	C	G	F*	Ø K	Ø N	Panel Preparation Ø D
	Knurled Head		Smooth Head															
	Phillips / Slotted	TORX®/Slotted	Phillips / Slotted	TORX®/Slotted														
M3 x 0.5	52-SM-3311-K-R	52-SM-3411-K-R	52-SM-3311-N-R	52-SM-3411-N-R	14	9.6	0.8 (.03)	5.3 (.21)	7	6.8	5.5	7.6	7	2.5	0.5	5.6	8.6	5.6 +0.08/-0 (.220 +.003/-.000)
	52-SM-3321-K-R	52-SM-3421-K-R	52-SM-3321-N-R	52-SM-3421-N-R	(.55)	(.38)	2.3 (.09)	6.8 (.27)	(.28)	(.27)	(.217)	(.30)	(.28)	(.1)	(.02)			
4-40	52-SM-1311-K-R	52-SM-1411-K-R	52-SM-1311-N-R	52-SM-1411-N-R	14	9.6	0.8 (.03)	5.3 (.21)	7	6.8	5.5	7.6	7	2.5	0.5	(.22)	(.34)	5.6 +0.08/-0 (.220 +.003/-.000)
	52-SM-1321-K-R	52-SM-1421-K-R	52-SM-1321-N-R	52-SM-1421-N-R	(.55)	(.38)	2.3 (.09)	6.8 (.27)	(.28)	(.27)	(.217)	(.30)	(.28)	(.1)	(.02)			
6-32	52-SM-2311-K-R	52-SM-2411-K-R	52-SM-2311-N-R	52-SM-2411-N-R	15.7	10.7	0.7 (.028)	5.8 (.23)	7.9	7.6	6.2	8.1	8.1	2.5	0.8	6.4	10.2	6.4 +0.08/-0 (.252 +.003/-.000)
	52-SM-2321-K-R	52-SM-2421-K-R	52-SM-2321-N-R	52-SM-2421-N-R	(.62)	(.42)	2.2 (.087)	7.4 (.29)	(.31)	(.30)	(.244)	(.32)	(.32)	(.1)	(.03)	(.25)	(.40)	

Other options available. For complete details on variety, part numbers, installation and specification, go to



www.southco.com/52

TORX is a registered trademark of ACUMENT® Intellectual Properties, LLC

Dimensions in millimeters (inch) unless otherwise stated



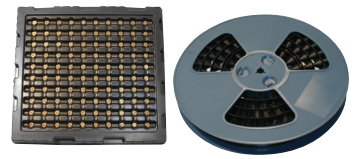

Southco Surface Mounted Technology (SMT) Captive Screws include installation and packaging features for installation onto PC Boards during the Reflow Process as a surface mounted device (SMD).

SMT product installation is offered on these Southco Captive Screws for 4-40, 6-32 and M3 thread sizes:

- 47 Styled Knob Series
- 4C Prism Series
- 52 Miniature Series

Installation Features

Each Southco SMT style captive screw includes a polyimide patch covering the screw head tool recess allowing for vacuum pick up during placement on the PC Board. The screw threads are protected from excess solder during the reflow process by a plug pre-assembled to the screw by Southco. The patch and plug are then removed after the final cool down phase.

Screw as Shipped in Reel or Tray Pack

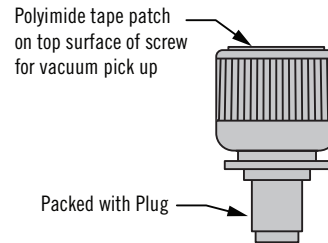

Preparing the PC Board to accept SMT Captive Screws

- See literature for optimum soldering pad surface area for the specific Southco Captive Screw being utilized

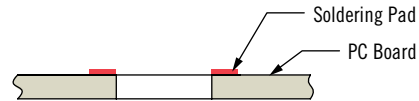

Packaging Features/Options

- Tray Pack
- Reel Pack

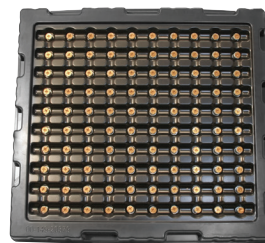

Tray Pack



Reel Pack

Reflow Process

- Reflow of Solder
 - Pre-heat
 - Soak
 - Reflow
 - Cooling
- Cleaning
 - Remove excess solder paste



52 Captive Screws

Miniature series · Flare-in style

- Smaller footprint for limited space applications
- Heat treated steel screw for optimum strength

Material and Finish

Screw: Hardened carbon steel, zinc plated, chromate, plus sealer

Spring: 300 series stainless steel, passivated

Standoff: Aluminum natural

Installation tool: Hardened carbon steel, zinc plated, chromate, plus sealer

Installation Notes

1. Prepare panel as shown
2. Use light pressure to flare standoff, assuring parallel surfaces on the punch and installation tool

Part Number

See table

Recess Styles

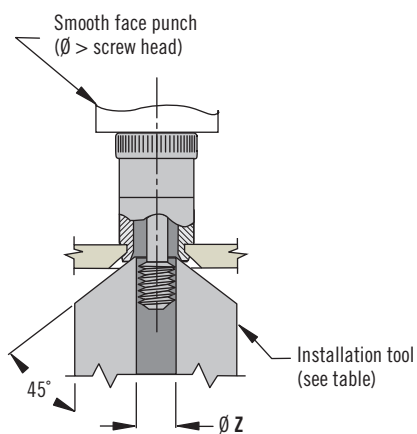
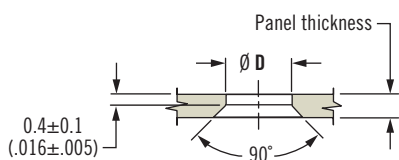
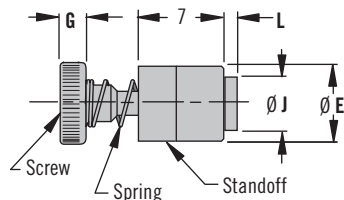
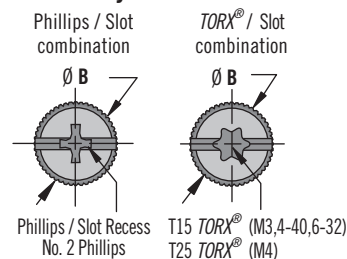

Knob Height and Screw Projection

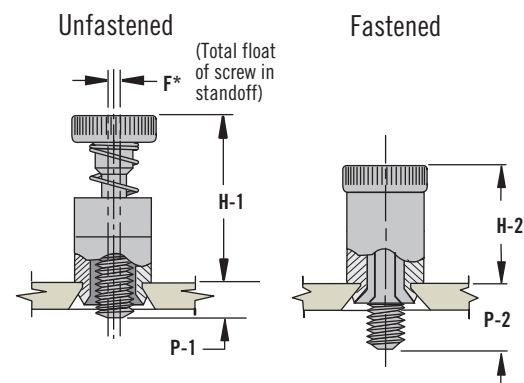

F* - Value represents float in unfastened position

Notes: P-1, P-2 measured from the top side of panel

Thread Size	Panel Thickness		Part Number						Ø B	Ø E	F	G	H-1	H-2	Ø J	L	P-1	P-2	Panel Preparation		Tool Part No.
			Knurled Head		Smooth Head		Ø D	Ø Z													
	Min.	Max.	Phillips / Slotted	TORX® / Slotted	Phillips / Slotted	TORX® / Slotted															
4-40	0.8 (.031)	2.4 (.094)	52-19-11-4	52-17-11-4	52-1A-11-4	52-18-11-4	7 (.28)	6.2 (.245)	0.5 (.018)	2.5 (.1)	14 (.55)	9.6 (.38)	4.6 (.183)	1 (.041)	0.8 (.031)	5.3 (.21)	4.75 ^{+0.08} ₋₀ (.187 ^{+0.003} ₋₀)	3 (.120)	47-104		
6-32	1.5 (.058)	3.2 (.125)	52-29-21-4	52-27-21-4	52-2A-21-4	52-28-21-4	8 (.31)	7 (.28)	0.7 (.028)	2.5 (.1)	15 (.59)	9.6 (.38)	5.3 (.209)	1.8 (.07)	1.8 (.07)	6.8 (.27)	5.41 ^{+0.08} ₋₀ (.213 ^{+0.003} ₋₀)	3.6 (.141)	47-106		
M3 x 0.5	0.8 (.031)	2.4 (.094)	52-39-11-4	52-37-11-4	52-3A-11-4	52-38-11-4	7 (.28)	6.2 (.245)	0.6 (.023)	2.5 (.1)	14 (.55)	9.6 (.38)	4.6 (.183)	1 (.041)	0.8 (.031)	5.3 (.21)	4.75 ^{+0.08} ₋₀ (.187 ^{+0.003} ₋₀)	3 (.120)	47-104		
M4 x 0.7	1.5 (.058)	3.2 (.125)	52-49-21-4	52-47-21-4	52-4A-21-4	52-48-21-4	9.4 (.37)	8.7 (.34)	0.7 (.028)	3 (.12)	15.2 (.60)	10.1 (.40)	6.7 (.26)	1.8 (.07)	1.8 (.07)	6.8 (.27)	6.76 ^{+0.1} _{-0.04} (.266 ^{+0.003} ₋₀)	4.2 (.166)	47-108		

Note: Subtract .25 (.01) from Ø B for smooth head style.

TORX is a registered trademark of ACUMENT® Intellectual Properties, LLC

Dimensions in millimeters (inch) unless otherwise stated



www.southco.com/52

southco
CONNECT · CREATE · INNOVATE

52 Captive Screws

Miniature series · Press-in style



Recess Styles

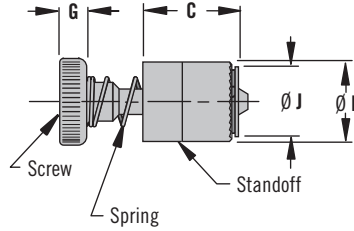
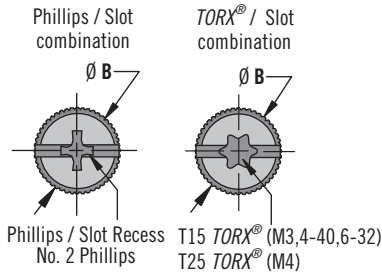

- Smaller footprint for limited space applications
- Heat treated steel screw for optimum strength

Material and Finish

Screw: Hardened carbon steel, zinc plated, chromate, plus sealer
 Spring: 300 series stainless steel, passivated
 Standoff: Carbon steel, zinc plated, chromate, plus sealer

Installation Notes

For use in most aluminum or in low carbon steels that are 1/4 hard or softer

Knob Height and Screw Projection

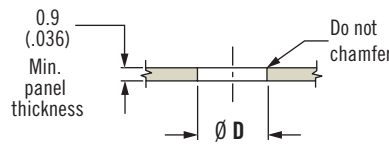
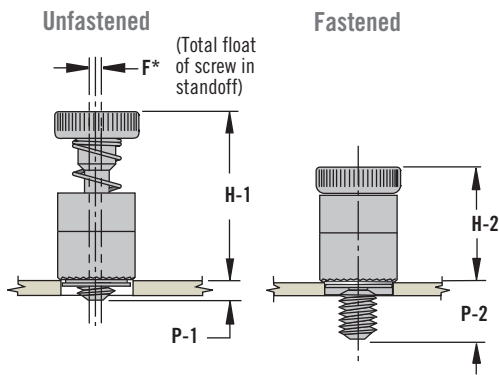

Notes: Recommended minimum distance from edge of panel to centerline of hole is 1.5 x Ø D for press-in version.

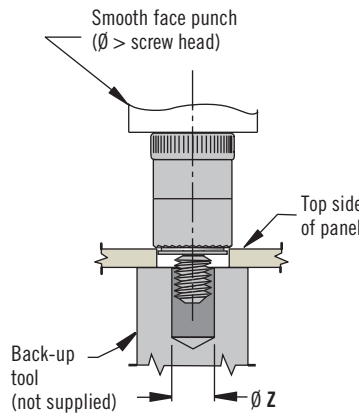

* Value represents float in unfastened position
 Notes: P-1, P-2 measured from the top side of panel

Part Number

See table



See page 543 for additional installation guidelines

Thread Size	Part Number				Ø B	C	Ø E	F*	G	H-1	H-2	Ø J	P-1	P-2	Panel Preparation	
	Knurled Head		Smooth Head												Ø D	Ø Z
	Phillips / Slotted	TORX® / Slotted	Phillips / Slotted	TORX® / Slotted												
4-40	52-19-51-4	52-17-51-4	52-1A-51-4	52-18-51-4	7	7.9	6.4	0.5	2.5	14	9.6	5.5	0.9 (.036)	5.3 (.21)	5.56 ^{+0.08} ₋₀	3
	52-19-53-4	52-17-53-4	52-1A-53-4	52-18-53-4	(.28)	(.31)	(.25)	(.018)	(.1)	(.55)	(.38)	(.217)	2.5 (.1)	6.8 (.27)	(.219 ^{+0.003} ₋₀)	(.120)
6-32	52-29-51-4	52-27-51-4	52-2A-51-4	52-28-51-4	8	8.6	7	0.7	2.5	15.5	10.4	6.3	0.9 (.036)	6.1 (.24)	6.35 ^{+0.08} ₋₀	3.7
	52-29-53-4	52-27-53-4	52-2A-53-4	52-28-53-4	(.31)	(.34)	(.28)	(.028)	(.1)	(.61)	(.41)	(.247)	2.5 (.1)	7.6 (.30)	(.250 ^{+0.003} ₋₀)	(.144)
M3 X 0.5	52-39-51-4	52-37-51-4	52-3A-51-4	52-38-51-4	7	7.9	6.4	0.6	2.5	14	9.6	5.5	0.9 (.036)	5.3 (.21)	5.56 ^{+0.08} ₋₀	3.2
	52-39-53-4	52-37-53-4	52-3A-53-4	52-38-53-4	(.28)	(.31)	(.25)	(.023)	(.1)	(.55)	(.38)	(.217)	2.5 (.1)	6.8 (.27)	(.219 ^{+0.003} ₋₀)	(.126)
M4 X 0.7	52-49-51-4	52-47-51-4	52-4A-51-4	52-48-51-4	9.4	8.6	8.7	0.7	3	16	10.8	7.9	0.9 (.036)	6.1 (.24)	8 ⁺⁰ _{-0.08}	4.4
	52-49-53-4	52-47-53-4	52-4A-53-4	52-48-53-4	(.37)	(.34)	(.34)	(.028)	(.12)	(.63)	(.43)	(.31)	2.5 (.1)	7.6 (.30)	(.315 ^{+0.003} _{-0.003})	(.173)





52 Overmold Captive Screws

Miniature series · Flare-in style

- Smaller footprint for limited space applications
- Heat treated steel screw for optimum strength
- Designate access points with color
- Color match captive screws to your industrial design

Material and Finish

Screw: Hardened carbon steel, zinc plated, chromate, plus sealer

Spring: 300 series stainless steel, passivated

Standoff: Aluminum natural

Knob: PC/ABS

Installation tool: Hardened carbon steel, zinc plated, chromate, plus sealer

Performance Details

Flamability Rating: UL94-V0

Installation Notes

1. Prepare panel as shown
2. Use light pressure to flare standoff, assuring parallel surfaces on the punch and installation tool

Part Number

See table

Recess Styles*

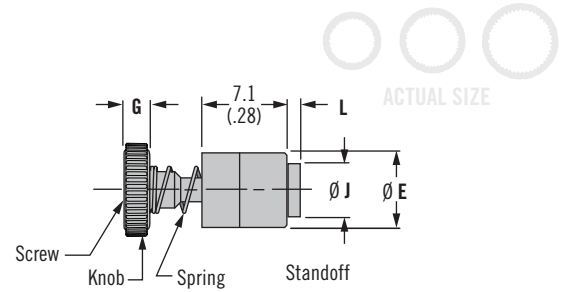
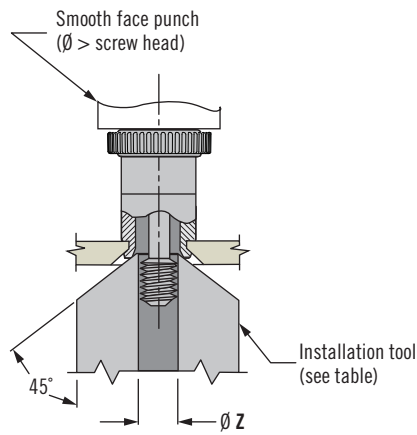
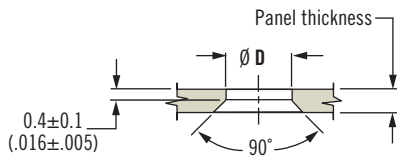
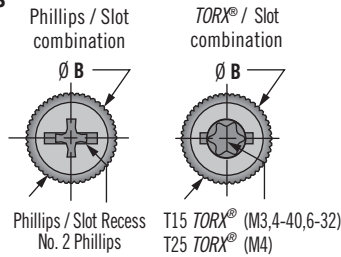

Knob Height and Screw Projection

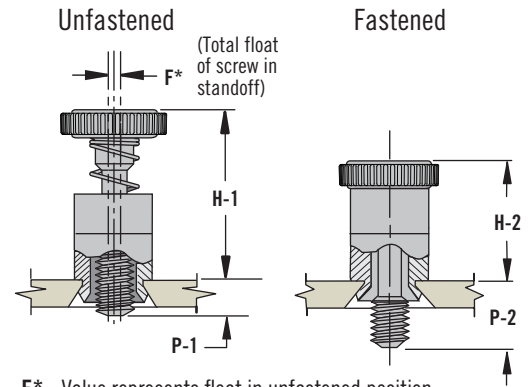

F* - Value represents float in unfastened position
Notes: P-1, P-2 measured from the top side of panel

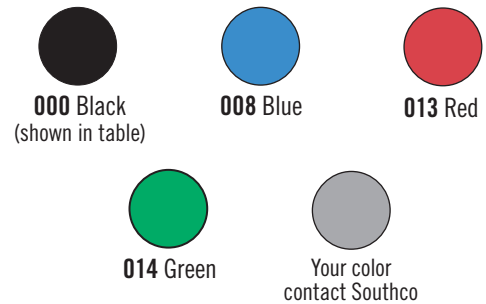

Specifying Color: To indicate color, change the last three digits of the part number

Example: 52-11-11-4-000 Black, 52-11-11-4-013 Red

Thread Size	Panel Thickness		Part Number														Panel Preparation		Tool Part No.			
			Knurled Head				Smooth Head				B Knurled Head	B Smooth Head	Ø E	F	G	H-1	H-2	Ø J		L	P-1	P-2
	Min.	Max.	Phillips / Slotted	TORX® / Slotted	Phillips / Slotted	TORX® / Slotted																
4-40	0.8 (.031)	2.4 (.094)	52-11-11-4-000 *	52-15-11-4-000 *	52-13-11-4-000 *	52-16-11-4-000 *	8.1 (.32)	7.8 (.31)	6.2 (.245)	0.5 (.018)	2.5 (.1)	14 (.55)	9.6 (.38)	4.6 (.183)	1 (.041)	0.8 (.031)	5.3 (.21)	4.75 ^{+0.08} ₋₀ (.187 ^{+0.03} ₋₀)	3 (.120)	47-104		
6-32	1.5 (.058)	3.2 (.125)	52-29-21-4-000	52-27-21-4-000	52-2A-21-4-000	52-28-21-4-000	8.8 (.35)	8.5 (.33)	7 (.28)	0.7 (.028)	2.5 (.1)	15 (.59)	9.6 (.38)	5.3 (.209)	1.8 (.07)	1.8 (.07)	6.8 (.27)	5.41 ^{+0.08} ₋₀ (.213 ^{+0.03} ₋₀)	3.6 (.141)	47-106		
M3 x 0.5	0.8 (.031)	2.4 (.094)	52-31-11-4-000 *	52-35-11-4-000*	52-33-11-4-000 *	52-36-11-4-000*	8.1 (.32)	7.8 (.31)	6.2 (.245)	0.6 (.023)	2.5 (.1)	14 (.55)	9.6 (.38)	4.6 (.183)	1 (.041)	0.8 (.031)	5.3 (.21)	4.75 ^{+0.08} ₋₀ (.187 ^{+0.03} ₋₀)	3 (.120)	47-104		
M4 x 0.7	1.5 (.058)	3.2 (.125)	52-49-21-4-000	52-45-21-4-000 *	52-4A-21-4-000	52-46-21-4-000 *	10.3 (.41)	10 (.39)	8.7 (.34)	0.7 (.028)	3 (.12)	15.2 (.60)	10 (.40)	6.7 (.26)	1.8 (.07)	1.8 (.07)	6.8 (.27)	6.76 ^{+0.1} ₋₀ (.266 ^{+0.05} ₋₀)	4.2 (.166)	47-108		

*Part Numbers not available with combination head styles; Phillips or TORX® only

TORX is a registered trademark of ACUMENT® Intellectual Properties, LLC



www.southco.com/52

Dimensions in millimeters (inch) unless otherwise stated



52 Overmold Captive Screws

Miniature series · Press-in style



Recess Styles*

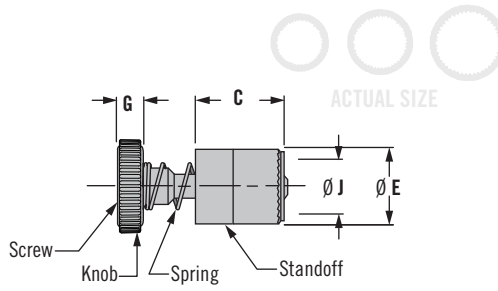
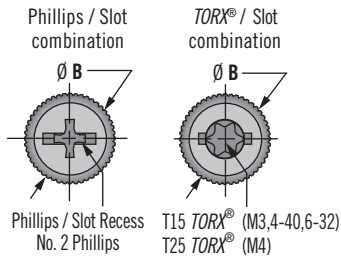

- Smaller footprint for limited space applications
- Heat treated steel screw for optimum strength
- Designate access points with color
- Color match captive screws to your industrial design

Knob Height and Screw Projection

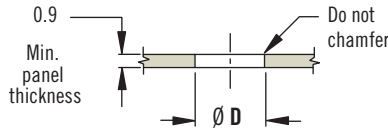
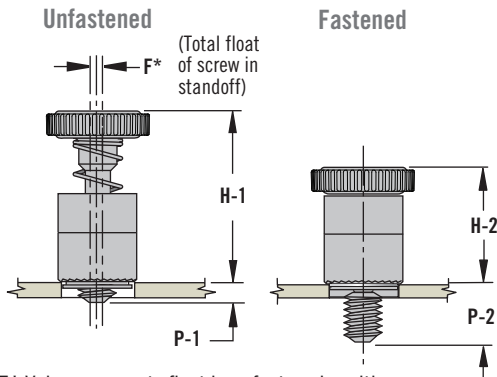

Notes: Recommended minimum distance from edge of panel to centerline of hole is 1.5 x Ø D for press-in version.

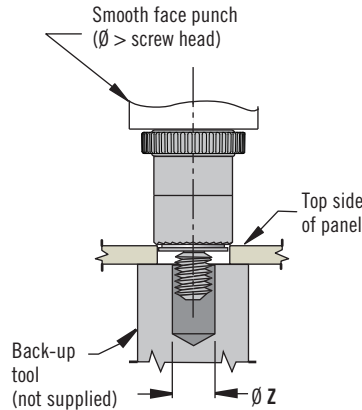

Material and Finish

Screw: Hardened carbon steel, zinc plated, chromate, plus sealer
 Spring: 300 series stainless steel, passivated
 Standoff: Carbon steel, zinc plated, chromate, plus sealer
 Knob: PC/ABS

Performance Details

Flamability Rating: UL94-V0

Installation Notes

For use in most aluminum or in low carbon steels that are 1/4 hard or softer. Visit www.southco.com for more information.

Part Number

See table

F* Value represents float in unfastened position
 Notes: P-1, P-2 measured from the top side of panel

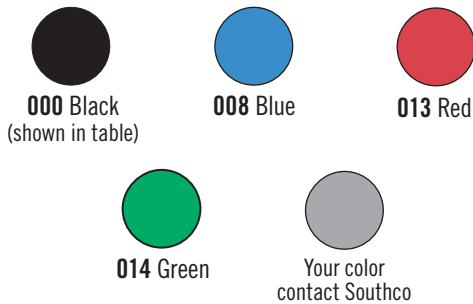

Specifying Color: To indicate color, change the last three digits of the part number

Example: 52-11-11-4-000 Black, 52-11-11-4-013 Red

Visit www.southco.com for additional installation guidelines

Thread Size	Part Number				B Knurled Head	B Smooth Head	C	Ø E	F*	G	H-1	H-2	Ø J	P-1	P-2	Panel Preparation	
	Knurled Head		Smooth Head													Ø D	Ø Z
	Phillips / Slotted	TORX® / Slotted	Phillips / Slotted	TORX® / Slotted													
4-40	52-11-51-4-000*	52-15-51-4-000*	52-13-51-4-000*	52-16-51-4-000*	8.1 (.32)	7.8 (.31)	7.9 (.31)	6.4 (.25)	0.5 (.018)	2.5 (.1)	14 (.55)	9.6 (.38)	5.5 (.217)	0.9 (.036)	5.3 (.21)	5.56 ^{+0.08} ₀ (.219 ⁺⁰ _{-.003})	3 (.120)
	52-11-53-4-000*	52-15-53-4-000*	52-13-53-4-000*	52-16-53-4-000*										2.5 (.1)	6.8 (.27)		
6-32	52-29-51-4-000	52-27-51-4-000	52-2A-51-4-000	52-28-51-4-000	8.8 (.35)	8.5 (.33)	8.6 (.34)	7 (.28)	0.7 (.028)	2.5 (.1)	15.5 (.61)	10.4 (.41)	6.3 (.247)	0.9 (.036)	6.1 (.24)	6.35 ^{+0.03} ₀ (.250 ⁺⁰ _{-.003})	3.7 (.144)
	52-29-53-4-000	52-27-53-4-000	52-2A-53-4-000	52-28-53-4-000										2.5 (.1)	7.6 (.30)		
M3 X 0.5	52-31-51-4-000*	52-35-51-4-000*	52-33-51-4-000*	52-36-51-4-000*	8.1 (.32)	7.8 (.31)	7.9 (.31)	6.4 (.25)	0.6 (.023)	2.5 (.1)	14 (.55)	9.6 (.38)	5.5 (.217)	0.9 (.036)	5.3 (.21)	5.56 ^{+0.08} ₀ (.219 ^{+0.003} _{-.000})	3.2 (.126)
	52-31-53-4-000*	52-35-53-4-000*	52-33-53-4-000*	52-36-53-4-000*										2.5 (.1)	6.8 (.27)		
M4 X 0.7	52-49-51-4-000	52-45-51-4-000*	52-4A-51-4-000	52-46-51-4-000*	10.3 (.41)	10 (.39)	8.6 (.34)	8.7 (.34)	0.7 (.028)	3 (.12)	16 (.63)	10.8 (.43)	7.9 (.31)	0.9 (.036)	6.1 (.24)	8 ⁺⁰ ₀ (.315 ⁺⁰ _{-.003})	4.4 (.173)
	52-49-53-4-000	52-45-53-4-000*	52-4A-53-4-000	52-46-53-4-000*										2.5 (.1)	7.7 (.30)		

Note:*Part Numbers not available with combination head styles; Phillips or TORX® only

TORX is a registered trademark of ACUMENT® Intellectual Properties, LLC



Dimensions in millimeters (inch) unless otherwise stated



www.southco.com/52



52 Captive Screws

Miniature low profile series · Press-in style

- Low profile for limited space application
- Heat treated steel screw for optimum strength
- Designate access points with color
- Color match captive screws to your industrial design

Material and Finish

Screw: Hardened carbon steel, zinc plated, chromate, plus sealer

Spring: 300 series stainless steel, passivated

Standoff: Carbon steel, zinc plated, chromate, plus sealer

Prism: PC/ABS

Performance Details

Flamability Rating: UL94-V0

Installation Notes

For use in most aluminum or low carbon steels that are 1/4 hard or softer. Visit www.southco.com for more information.

Part Number

See table

Recess Styles

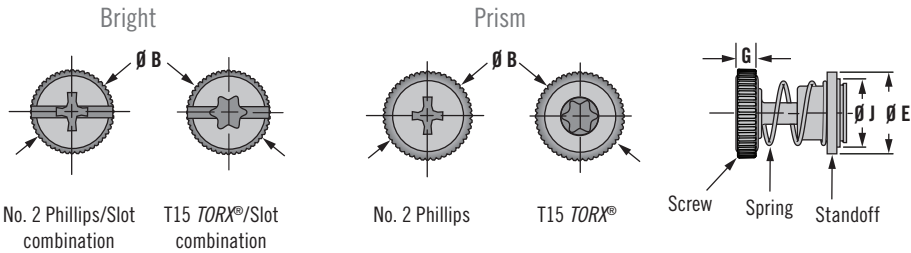

Knob Height and Screw Projection

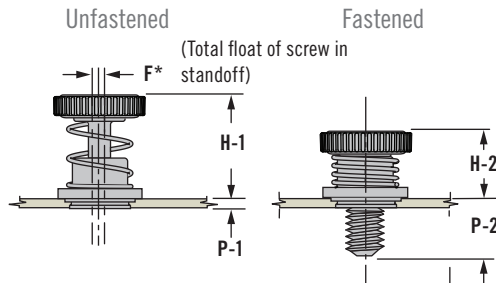

F* - Value represents float in unfastened position
 Notes: P-1, P-2 measured from the top side of panel

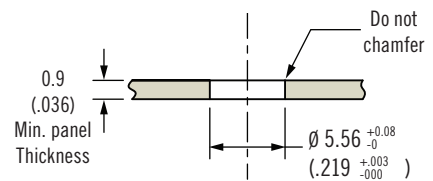

Notes: Recommended minimum distance from edge of panel to centerline of hole is 1.5 x Ø for press-in version.

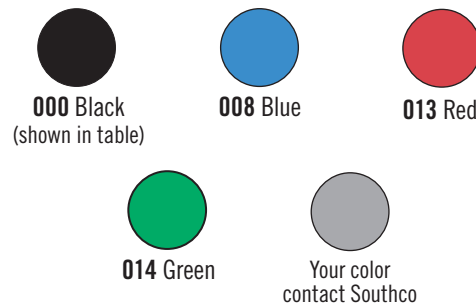

Specifying Color: To indicate color, change the last three digits of the part number
Example: 52-A11-51-4-000 Black, 52-A11-51-4-013 Red

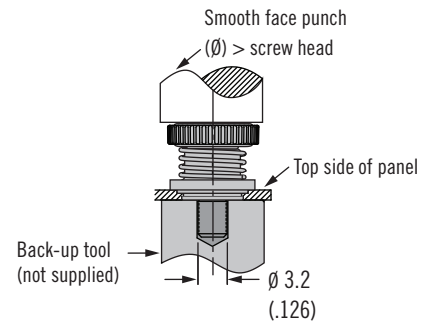

Visit www.southco.com for additional installation guidelines

Color/ Appearance	Thread Size	Part Number						H-1	H-2	P-1	P-2	Ø J	Ø E	G	F*
		Knurled Head			Smooth Head										
		Phillips / Slotted	TORX®/ Slotted	Ø B	Phillips / Slotted	TORX®/ Slotted	Ø B								
Bright	4-40	52-A19-51-4	52-A17-51-4	7	52-A1A-51-4	52-A18-51-4	6.75	9	6	0.9	3.9	6.35	7.6	1.7	0.5
	M3 x 0.5	52-A39-51-4	52-A37-51-4	(.28)	52-A3A-51-4	52-A38-51-4	(.27)	(.36)	(.24)	(.04)	(.17)	(.25)	(.3)	(.07)	(.02)
		Phillips	TORX®	Ø B	Phillips	TORX®	Ø B								
Prism (black shown)	4-40	52-A11-51-4-000	52-A15-51-4-000	8.1	52-A13-51-4-000	52-A16-51-4-000	7.8	9.5	6.2	0.9	3.9	6.35	7.6	2.2	0.5
	M3 x 0.5	52-A31-51-4-000	52-A35-51-4-000	(.32)	52-A33-51-4-000	52-A36-51-4-000	(.31)	(.37)	(.26)	(.04)	(.17)	(.25)	(.3)	(.09)	(.02)

TORX is a registered trademark of ACUMENT® Intellectual Properties, LLC



www.southco.com/52

Dimensions in millimeters (inch) unless otherwise stated



52 Captive Screws

Miniature low profile series · Surface Mount Technology (SMT) Style

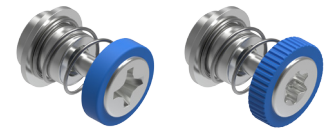

477B

Recess Styles

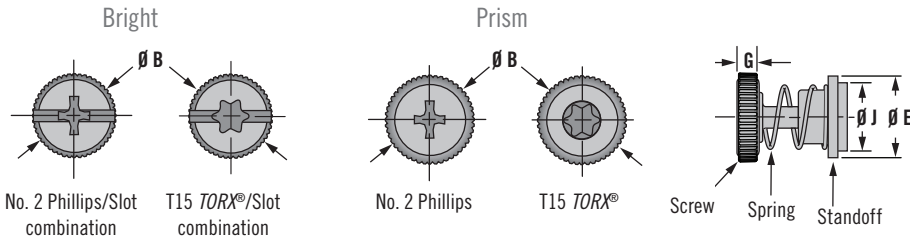

Knob Height and Screw Projection

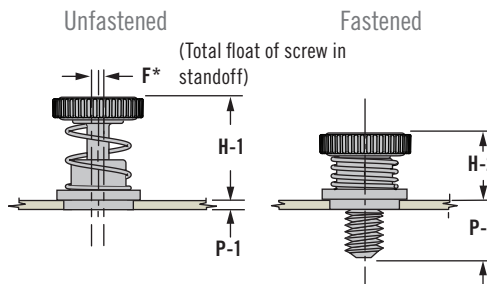

F* Value represents float in unfastened position
Notes: P-1, P-2 measured from the top side of panel

PC Board Preparation

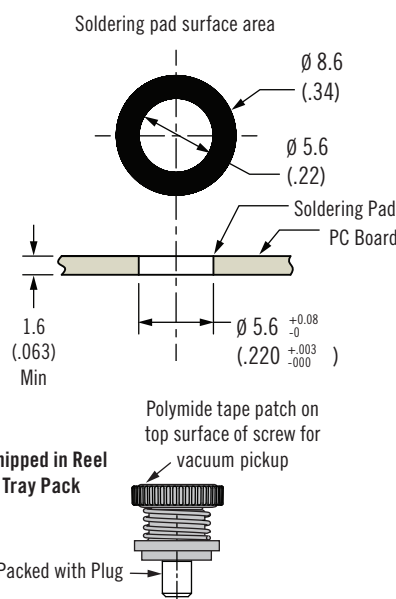

- For installation to PC Board material utilizing surface mount technology
- Heat treated steel screw for optimum strength
- Designate access points with color
- Color match captive screws to your industrial design

Material and Finish

Screw: Hardened carbon steel, zinc plated, chromate, plus sealer
Spring: 300 series stainless steel, passivated
Standoff: Carbon steel, tin plated, chromate, plus sealer
Prism: High heat resistant plastic

Performance Details

Flamability Rating: UL94-V0

Installation Notes

Visit www.southco.com for additional installation guidelines

Part Number

See table

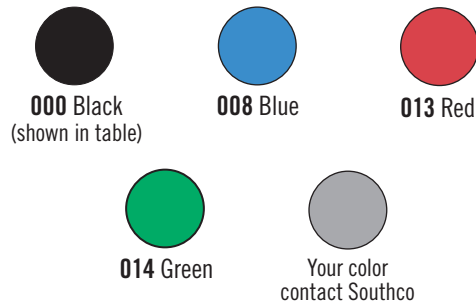

Specifying Color: To indicate color, change the last three digits of the part number

Example: 52-SM-A1111-K000-R, 52-SM-A1111-K013-R

Visit www.southco.com for additional installation guidelines

Screw as Shipped in Reel Pack or Tray Pack

Specify Package - SMT Style

Indicate package option with last digit of the part number

Example

52-SM-A1311-K-R: Reel Package (as shown in table)

52-SM-A1311-K-T: Tray Package

Color/ Appearance	Thread Size	Part Number						H-1	H-2	P-1	P-2	Ø J	Ø E	G	F*
		Knurled Head			Smooth Head										
		Phillips / Slotted	TORX®/ Slotted	Ø B	Phillips / Slotted	TORX®/ Slotted	Ø B								
Bright	4-40	52-SM-A1311-K-R	52-SM-A1411-K-R	7	52-SM-A1311-N-R	52-SM-A1411-N-R	6.75	8.4	5.4	1.5	4.5	5.5	7.6	1.7	0.5
	M3 x 0.5	52-SM-A3311-K-R	52-SM-A3411-K-R	(.28)	52-SM-A3311-N-R	52-SM-A3411-N-R	(.27)	(.33)	(.21)	(.06)	(.18)	(.22)	(.3)	(.07)	(.02)
		Phillips	TORX®	Ø B	Phillips	TORX®	Ø B								
Prism (black shown)	4-40	52-SM-A1111-K000-R	52-SM-A1211-K000-R	8.1	52-SM-A1111-N000-R	52-SM-A1211-N000-R	7.8	8.9	5.9	1.5	4.5	5.5	7.6	2.2	0.5
	M3 x 0.5	52-SM-A3111-K000-R	52-SM-A3211-K000-R	(.32)	52-SM-A3111-N000-R	52-SM-A3211-N000-R	(.31)	(.35)	(.23)	(.06)	(.18)	(.22)	(.3)	(.09)	(.02)

TORX is a registered trademark of ACUMENT® Intellectual Properties, LLC

Installation Guidelines

for *SOUTHCO*® Self-Clinching products

Self-clinching product installation is offered on these *SOUTHCO*® products, making them easy-to-use captive panel fasteners:

- Captive Screws
- Receptacles for Quarter-turn Fasteners
- Receptacles for Fast-lead Thread Screws

When pressed into a properly prepared hole, self-clinching captive fasteners cold-flow (move) the panel material into the retaining groove of the fastener. This material then retains the fastener in the panel.

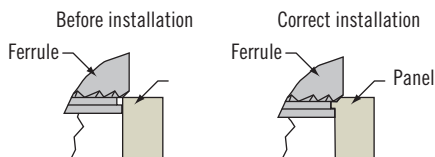

Successful press-in installations depend on:

Material:

The hardness of the panel material must not exceed *SOUTHCO*® recommendations. If the panel is too hard, the fastener will not install correctly.

Installation Holes:

Mounting holes may be drilled, punched, or cast.

- Hole edge: the top hole edge must be sharp but with no broken edges.

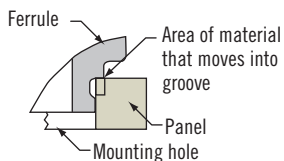

Do not chamfer or debur edge.

- Punched holes: use a punch and die with a small clearance to minimize the rollover and fracture angle.
- Hole diameter: measure the hole diameter at the panel surface on the side on which the fastener will be installed. The diameter must be within *SOUTHCO*® specifications for that product.

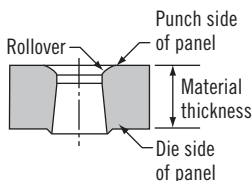

- If the hole is too large, not enough material will flow into the

retaining groove and the fastener may not be retained adequately.

- If the hole is too small, the fastener will not fit and installation may become difficult and unsafe.
- Hole distance from the edge of panel: the minimum recommended distance is 1.5 x the diameter of the mounting hole, unless otherwise indicated.

- Spring-loaded Plungers
- Captive Nuts
- Threaded Inserts

- Installing too close to the edge will cause the material to flow in the opposite direction, deforming the edge of the panel. To install closer to the edge, you may need to restrain the panel edge.

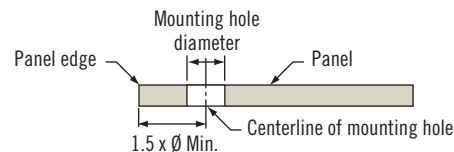

Panel Thickness:

The thickness of the panel at the mounting hole location must meet or exceed Southco's stated minimum recommendations.

If the material is too thin, panel deformation and/or damage to the fastener may result.

Installation is fast and easy if you follow these tips:

How to install: Use the recommended force where noted and a proper back-up tool.

- use any parallel-acting press
- use a punch whose diameter is larger than the head of the fastener

Installation Force: Proper installation requires an even distribution of adequate force. It does not depend on the distance the fastener is pressed into the panel.

- Southco does not recommend using a hammer. The impact force does not provide an even distribution of force to allow the panel material to completely flow into the fastener's retaining groove.
- Installation force varies from application to application, depending on the criteria noted above.
- On parts without a collar to provide a hard stop, press-in until the edge of the knurl is just barely visible.

When to Install:

Installation is recommended after plating or finishing has been applied to the panel.

The hole diameter must meet specifications before finish or plating is applied.

- Do not over-install parts. This interrupts the material and will reduce the retention strength.

