

TORX is a registered trademark of ACUMENT® Intellectual Properties, LLC

NOTES:

- A. GATE NOT ORIENTED WITH RECESS OR FRAME BREAK.
- B. FLASH HEIGHT GREATER THAN 0.3 NOT ACCEPTABLE.
- C. SURFACE IMPERFECTIONS: INSPECT PARTS FROM 0.6 METERS FOR 3 SECONDS, FOUR SURFACE IMPERFECTIONS MAX PER PART. SURFACE IMPERFECTIONS NO LARGER THAN 2.3mm DIAMETER, HEIGHT OR WIDTH.
- D. KNOB AND SCREW ARE SPRING LOAD OUTWARD, AS SHOWN BELOW.

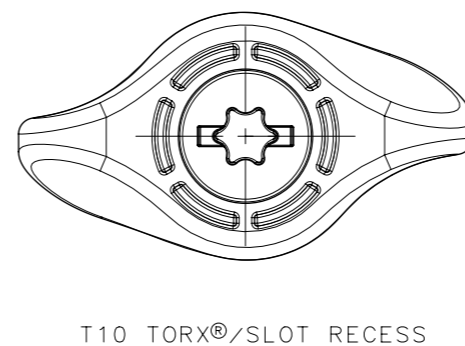
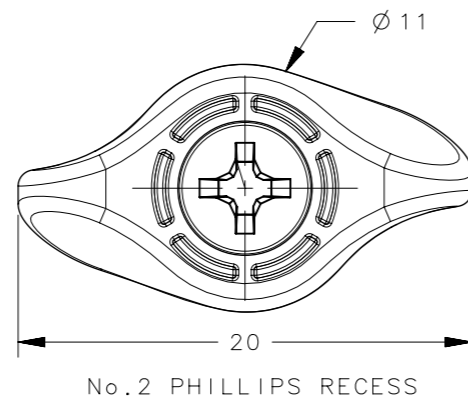

MATERIAL AND FINISH:

KNOB: PC/ABS UL94 V0 RATED, FLAME RETARDANT TRIARYLPHOSPHATE (DOES NOT CONTAIN BROMINATED CHLORINATED, OR HALOGENATED ADDITIVES)

SCREW: HEAT TREATED LOW CARBON STEEL ZINC PLATE, CHROMATE PLUS SEALER

STANDOFF: ALUMINUM, NATURAL

SPRING: 300 SERIES STAINLESS STEEL, PASSIVATED

REVISION HISTORY			
REV	DATE	BY	DESCRIPTION
A	07DEC2015	ER/LC	PRN: P2015-2454

TO INSTALL FASTENER:

1. DRILL OR PUNCH HOLE AS SHOWN BELOW.
2. PLACE STANDOFF INTO INSTALLATION HOLE.
3. PROVIDE SOLID BACK-UP BEHIND HOLE WITH CLEARANCE HOLE FOR SCREW AS SHOWN BELOW.
4. PRESS PART INTO PANEL UNTIL RECOMMENDED LOAD IS APPLIED.
5. PUNCH CANNOT TOUCH PLASTIC DURING INSTALLATION.

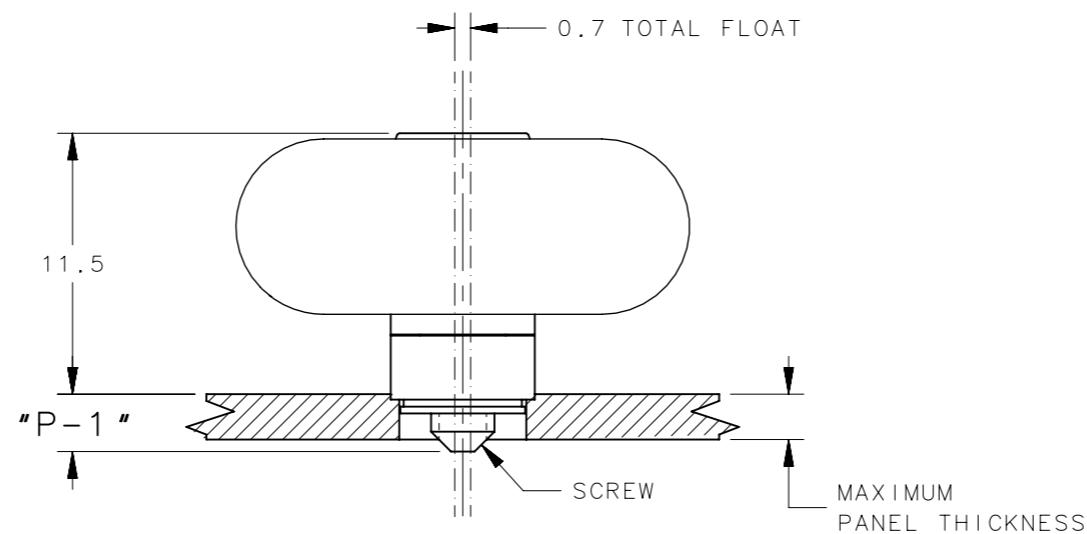
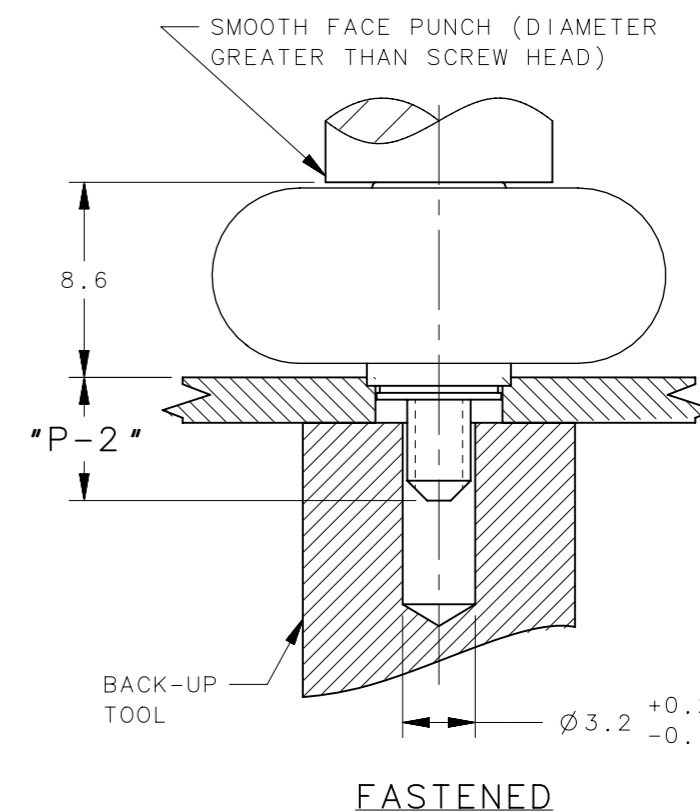

PART NUMBER: 4C-PH-04-2PO-WEEE SHOWN

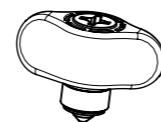
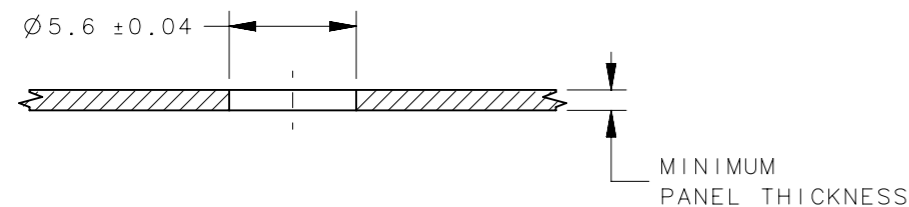
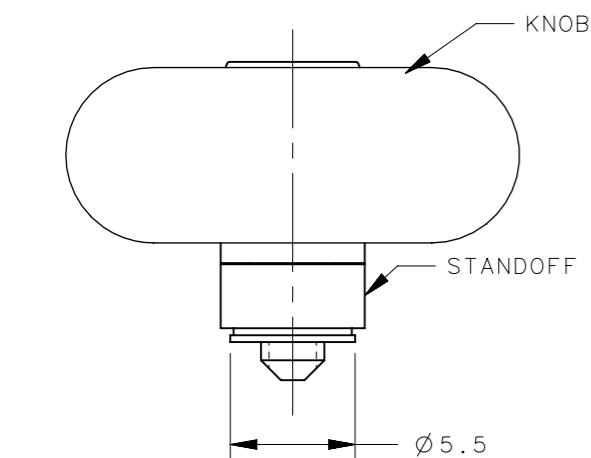

SCALE 1:1

"EEE" KNOB COLOR
000 - BLACK
FOR ADDITIONAL COLORS SEE J-47-0-3

T10 TORX®/SLOT	4C-TS-04-2PO-WEEE	2.5	5.4	0.9	-
	4C-TS-04-1PO-WEEE	0.8	3.7		
No.2 PHILLIPS	4C-PH-04-2PO-WEEE	2.5	5.4	0.9	-
	4C-PH-04-1PO-WEEE	0.8	3.7		
SCREW RECESS	PART NUMBER	"P-1"	"P-2"	MIN	MAX
		SCREW PROJECTION		PANEL THICKNESS	
	THIRD ANGLE PROJECTION				
	MILLIMETERS [IN]				
SURFACE AREA	TOLERANCES UNLESS OTHERWISE NOTED		southco CONNECT • CREATE • INNOVATE		
VOLUME	ALL DIMENSIONS WITHOUT TOLERANCES ARE FOR REFERENCE ONLY.				
PROPRIETARY ITEM	PER ASME Y14.5M-1994	SIZE A3	SYSTEM NX	DESCRIPTION 4C WING HEAD Captive Fastener 4-40 THREAD, PRESS-IN STYLE	
EXCEPT FOR USES EXPRESSLY GRANTED IN WRITING, INFORMATION DISCLOSED HEREON IS CONFIDENTIAL AND ALL RIGHTS, PATENT AND OTHERWISE, ARE RESERVED BY SOUTHCO, INC.		DRAWN BY ER	DATE 17APR2015	SCALE 3:1	SHEET 1 OF 1