

southco

PROPRIETARY ITEM - EXCEPT FOR USES EXPRESSLY GRANTED IN WRITING INFORMATION DISCLOSED HEREON IS CONFIDENTIAL AND ALL RIGHTS PATENT AND OTHERWISE ARE RESERVED BY SOUTHCO, INC.

SOUTHCO No. 47 CAPTIVE FASTENER
M3 THREAD, PCB STYLE

DATE: 10JUL2002
DRAWN/CHKD: DLH
SCALE: 2:1

DRAWING NUMBER: J-47-4-M3

REV	DATE	DRAWN/CHKD	DESCRIPTION

PART NUMBER	SCREW PROJECTION		PANEL THICKNESS	
	P-1	P-2	A, MIN	A, MAX
47-95-1X1-YZ	1.5	4.6	1.6	-
47-96-1X1-YZ	3.3	6.1		
47-97-1X1-YZ	4.8	7.6		
47-98-1X1-YZ	6.4	9.4		

RECESS	TORX [®] /SLOT
0 - SLOTTED	N/A
1 - T10 TORX [®]	N/A
4 - T10 TORX [®] /SLOT COMBINATION	0
8 - No.1 PHILLIPS/SLOT COMBINATION	1

MILLIMETERS

ALL DIMENSIONS WITHOUT TOLERANCES ARE FOR REFERENCE ONLY.

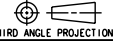

A3 PAPER SIZE

MATERIAL AND FINISH:
 KNOB: 6000 SERIES ALUMINUM
 SCREW: 400 SERIES STAINLESS STEEL, PASSIVATED; OR HARDENED CARBON STEEL, ZINC PLATE, CHROMATE PLUS SEALER (SEE *Z* TABLE) (NOTE: KNOB AND TOP OF SCREW AVAILABLE WITH POWDER COATING; SEE *Y* TABLE)
 FERRULE: 300 SERIES STAINLESS STEEL, PASSIVATED
 SPRING: 300 SERIES STAINLESS STEEL, PASSIVATED

Z KNOB TYPE AND SCREW MATERIAL

KNOB	SCREW MATERIAL	RECESS	
		SLOTTED TORX [®] PHILLIPS/SLOT	TORX [®] /SLOT
KNURLED	STAINLESS STEEL	0	N/A
SMOOTH	STAINLESS STEEL	1	N/A
KNURLED	STEEL	4	0
SMOOTH	STEEL	5	1

X SCREW RECESS

- 0 - SLOTTED
- 2 - No.1 PHILLIPS
- 4 - T10 TORX[®]
- 6 - T10 TORX[®]/SLOT COMBINATION
- 8 - No.1 PHILLIPS/SLOT COMBINATION

Y FINISH ON KNOB & SCREW HEAD

- 3 - BRIGHT
- 4 - CUSTOM COLOR. SEE J-47-0-3 FOR ADDITIONAL SUFFIX
- 7 - BLACK POWDER COATED

KNURLED KNOBS



SMOOTH KNOBS

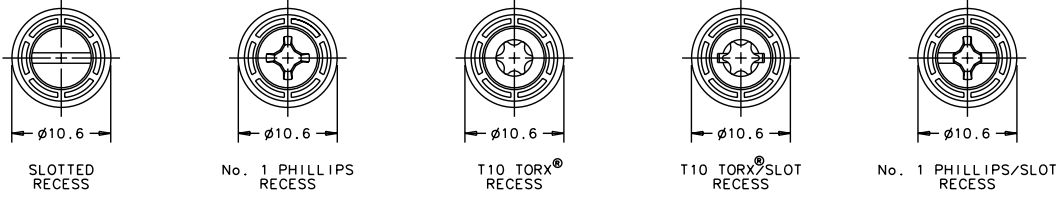

TO INSTALL FASTENER:

1. DRILL OR PUNCH HOLE AS SHOWN BELOW.
2. PLACE FERRULE INTO INSTALLATION HOLE.
3. PROVIDE SOLID BACK-UP BEHIND HOLE WITH CLEARANCE HOLE $\phi 3.2^{+0.1}$ FOR SCREW.
4. PRESS KNURL INTO PANEL UNTIL SHOULDER BOTTOMS OUT.

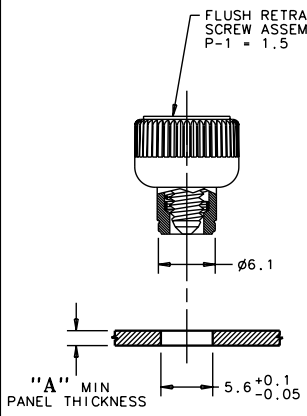

NOTE: KNOB AND SCREW ARE SPRING LOADED OUTWARD, AS SHOWN BELOW

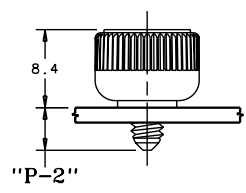
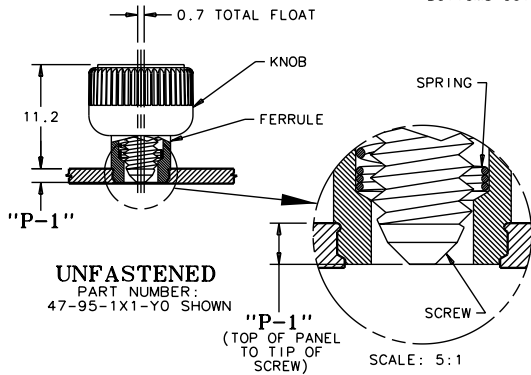

TORX[®] IS A REGISTERED TRADEMARK OF THE CAMCAR DIVISION OF TEXTRON, INC.

DRAWING NUMBER
J-47-4-M3