

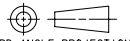

REV	DATE	DRAWN/CHKD	DESCRIPTION	ITEM	MATERIAL	FINISH
D	6-21-91	JAD/	REDRAWN FOR CLARITY/ SEE REC. DWG	RIVET	5052 ALUMINUM	NATURAL
E	6-18-90	CRW/	ADDED TOL. ( $\pm .010$ ) TO HEAD DIA.	PIN	302 STAINLESS STEEL	NATURAL
F	9-12-91	GW/	PRN: 38-163			
G	12APR93	ALC/	PRN: S-1-03			
H	15DEC93	RDG/	PRN: 38-177			
I	20SEP99	ESK/	PRN: 38-282			
J	12MAR2004	AAB/MJS	PRN: 2004-0270			
K	20MAY2004	AAB/RLR	PRN: 2004-0525			

INCHES

ALL DIMENSIONS WITHOUT TOLERANCES ARE FOR REFERENCE ONLY.

THIRD ANGLE PROJECTION      A PAPER SIZE

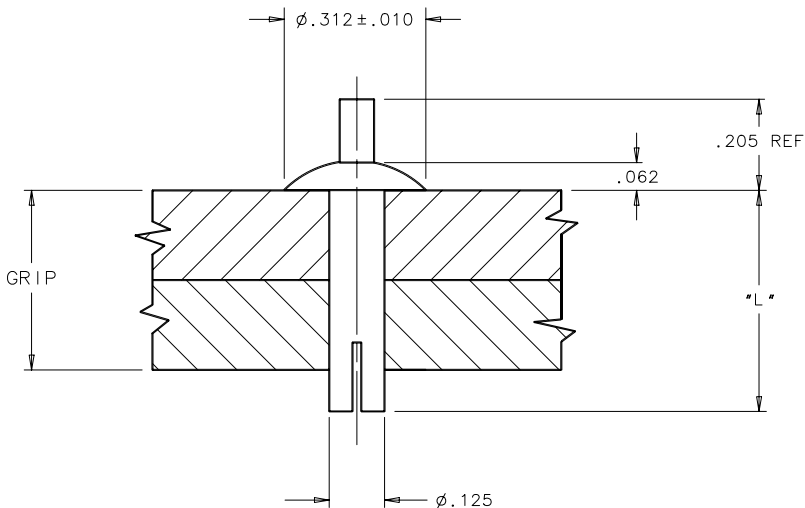

PART NO.	"L"	PART NO.		
		MIN.	NOM.	MAX.
38-204-02-13	.156	.046	.062	.078
↑ -03-13	.187	.078	.093	.109
↑ -04-13	.218	.109	.129	.140
↑ -05-13	.250	.140	.156	.171
↑ -06-13	.281	.171	.187	.203
↑ -07-13	.312	.203	.218	.234
↑ -08-13	.343	.234	.250	.265
↑ -09-13	.375	.265	.281	.296
↑ -10-13	.406	.296	.312	.328
↑ -11-13	.437	.328	.343	.359
↑ -12-13	.468	.359	.375	.390
↑ -13-13	.500	.390	.406	.421
↑ -14-13	.531	.421	.437	.453
↑ -15-13	.562	.453	.468	.484
↑ -16-13	.593	.484	.500	.515
↑ -17-13	.625	.515	.531	.546
↑ -18-13	.656	.546	.562	.578
↑ -19-13	.687	.578	.593	.609
↑ -20-13	.718	.609	.625	.640
↑ -21-13	.750	.640	.656	.671
↑ -22-13	.781	.671	.687	.702
↑ -23-13	.812	.702	.718	.733
↑ -24-13	.843	.733	.750	.765
38-204-26-13	.906	.796	.812	.828