

DATE	DRAWN	CHKD	SCALE	DRAWING NUMBER
8-5-58	ESK	ASK	.8:1	J-14-10-11-3

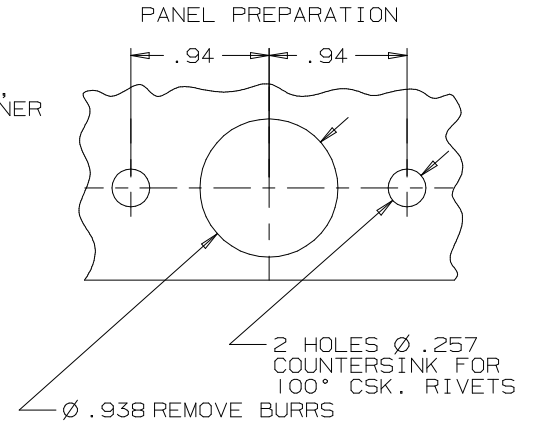
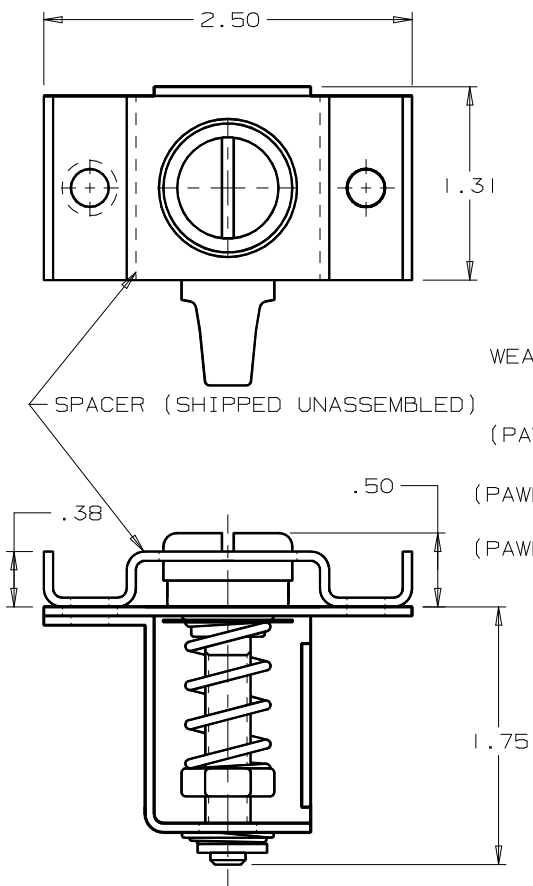

CONTACT POINT OF PAWL NOT TO EXCEED 1.25" FROM CENTERLINE OF SCREW

NOTE: SUB-ASSEMBLY DOES NOT INCLUDE SPACER.
 NOTE A: ZINC PLATE, CHROMATE PLUS SEALER.

FOR CHROME PLATED SCREW, CHANGE LAST UNIT OF ASS'Y AND SCREW PART NUMBER FROM -11 TO -12.

THESE ASSEMBLIES ARE NON-REPAIRABLE ITEMS AND COMPONENTS ARE NOT AVAILABLE AS REPLACEMENT OR REPAIR PARTS.

ITEM	MATERIAL	FINISH	NOTES
SCREW	STEEL	SEE NOTE A	
PAWL	STEEL	SEE NOTE A	
HOUSING	STEEL	SEE NOTE A	
SPRING	STAINLESS STEEL	PASSIVATE	
BUSHING	STEEL	SEE NOTE A	
CONICAL SPRING	STAINLESS STEEL	PASSIVATE	
RETAINER	STEEL	SEE NOTE A	
WEAR WASHER	STEEL	SEE NOTE A	
SPACER	STEEL	SEE NOTE A	SHIPPED UNASSEMBLED
ASSEMBLY	PAWL POSITION	GRIP RANGE	NOTES
14-10-61-11	FORWARD	.505 1.130	
14-10-71-11	FORWARD	.125 .750	SUB-ASSEMBLY
14-10-62-11	-----	.755 1.630	
14-10-72-11	-----	.375 1.250	SUB-ASSEMBLY
14-10-63-11	-----	.755 1.630	
14-10-73-11	-----	.375 1.250	SUB-ASSEMBLY
14-10-64-11	REVERSED	1.255 2.068	
14-10-74-11	REVERSED	.875 1.688	SUB-ASSEMBLY

REV.	DATE	BY-CHKD	REVISIONS
U	22MAR96	PCB	PRN: 14-88
V	24JUN96	RJB	PRN: 14-88B
W	08NOV96	JGK	PRN: S-1-06A