

NOTES:

- HANDLE-SHAFT SUB-ASSEMBLY CONSISTS OF:
 HANDLE: ABS, BLACK (WHEN F=5, FLAT HANDLE ONLY)
 STEEL, BRIGHT CHROME (WHEN F=1)
 SHAFT: STEEL, ZINC PLATE PLUS BRIGHT CHROMATE
 PIN: 18-8 STAINLESS STEEL, PASSIVATE
- CUP: STEEL, POWDER COAT BLACK (WHEN F=5, FLAT HANDLE ONLY)
 STEEL, BRIGHT CHROME (WHEN F=1)
- PART NUMBER 01-13-35 SHOWN.

(WITHOUT LOCK) 0.762 [.03] MIN.
 9.652 [.38] MAX.
 (WITH LOCK) 1.6 [.06] MIN.
 7.9 [.31] MAX.

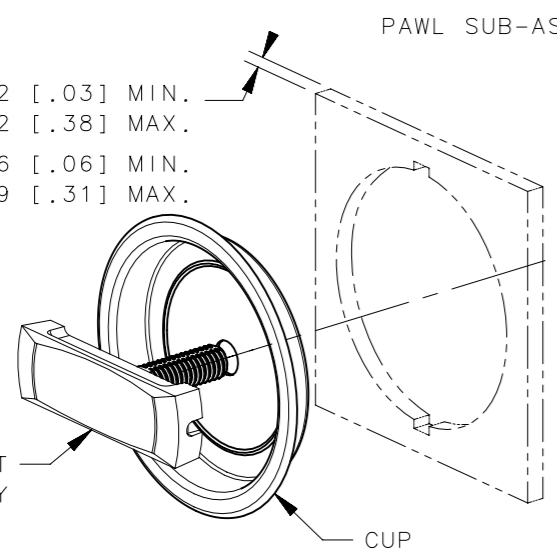

PAWL SUB-ASSEMBLY

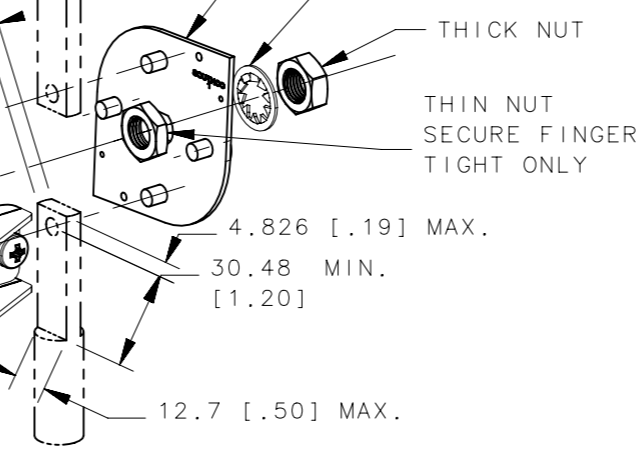
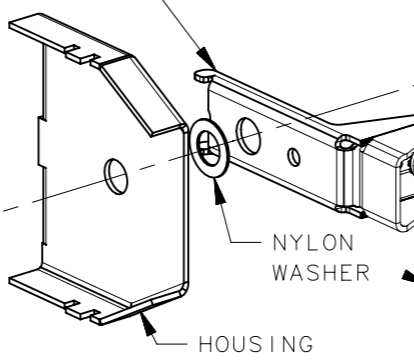

TYPE A INSTALLATION SHOWN
 FOR TYPE B INSTALLATION:
 1. ROTATE HOUSING AND PAWL SUB-ASSEMBLY 180°
 AROUND AXIS OF SHAFT.
 2. ROTATE HANDLE - SHAFT SUB-ASSEMBLY AND
 ACTUATOR SUB-ASSEMBLY 90° AROUND AXIS OF SHAFT.

REVISION HISTORY			
REV	DATE	BY	DESCRIPTION
A	07DEC2017	NBK/DMS	PRN: P2017-3012

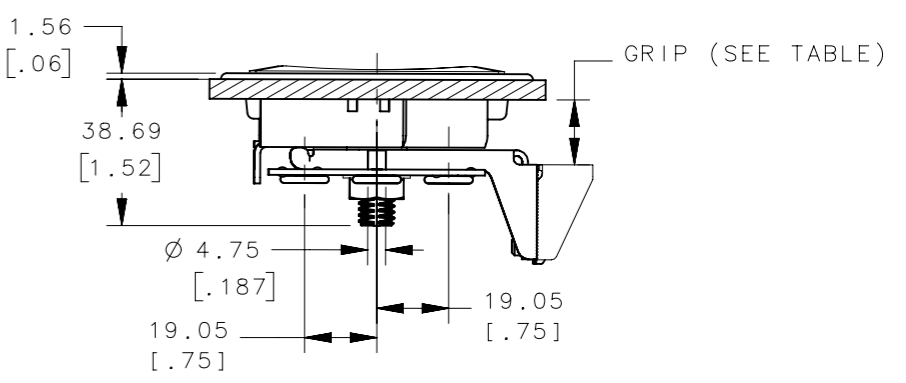
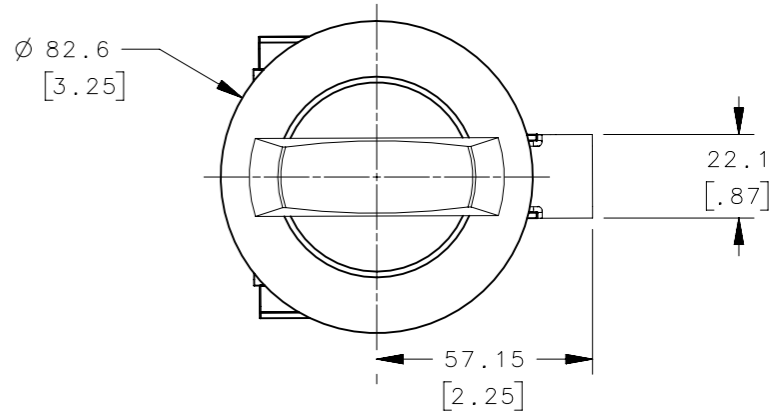

GRIP TABLE

G GRIP	GRIP RANGE	TYPE A	TYPE B	CAM TYPE
1	0-12.7	PERPENDICULAR	PARALLEL	SINGLE OR THREE POINT LATCHING
2	0-12.7	PARALLEL	PERPENDICULAR	SINGLE OR THREE POINT LATCHING
3	12.7-28.6	PERPENDICULAR	PARALLEL	SINGLE OR THREE POINT LATCHING
4	12.7-28.6	PARALLEL	PERPENDICULAR	SINGLE OR THREE POINT LATCHING
5	TWO POINT ONLY	PERPENDICULAR	PARALLEL	TWO POINT ONLY
6	TWO POINT ONLY	PARALLEL	PERPENDICULAR	TWO POINT ONLY

9	-	1	NYLON WASHER	NYLON	NATURAL
8	-	1	LOCKWASHER	STEEL	ZINC PLATE, BRIGHT CHROMATE
7	-	1	THIN NUT	STEEL	ZINC PLATE, BRIGHT CHROMATE
6	-	1	THICK NUT	STEEL	ZINC WITH BRIGHT CHROMATE
5	-	1	ACTUATOR, SUB-ASSEMBLY	STEEL	ZINC PLATE, BRIGHT CHROMATE
4	-	1	PAWL, SUB-ASSEMBLY	STEEL	ZINC WITH BRIGHT CHROMATE
3	-	1	HOUSING	STEEL	ZINC PLATE, BRIGHT CHROMATE
2	-	1	CUP	SEE NOTE 2	SEE NOTE 2
1	-	1	HANDLE-SHAFT, SUB-ASSEMBLY	SEE NOTE 1	SEE NOTE 1
-	01-L3-GF	1	FLUSH CUP LATCH ASSEMBLY	-	-
NO.	PART NUMBER		TYPE OF COMPONENT	MATERIAL	FINISH

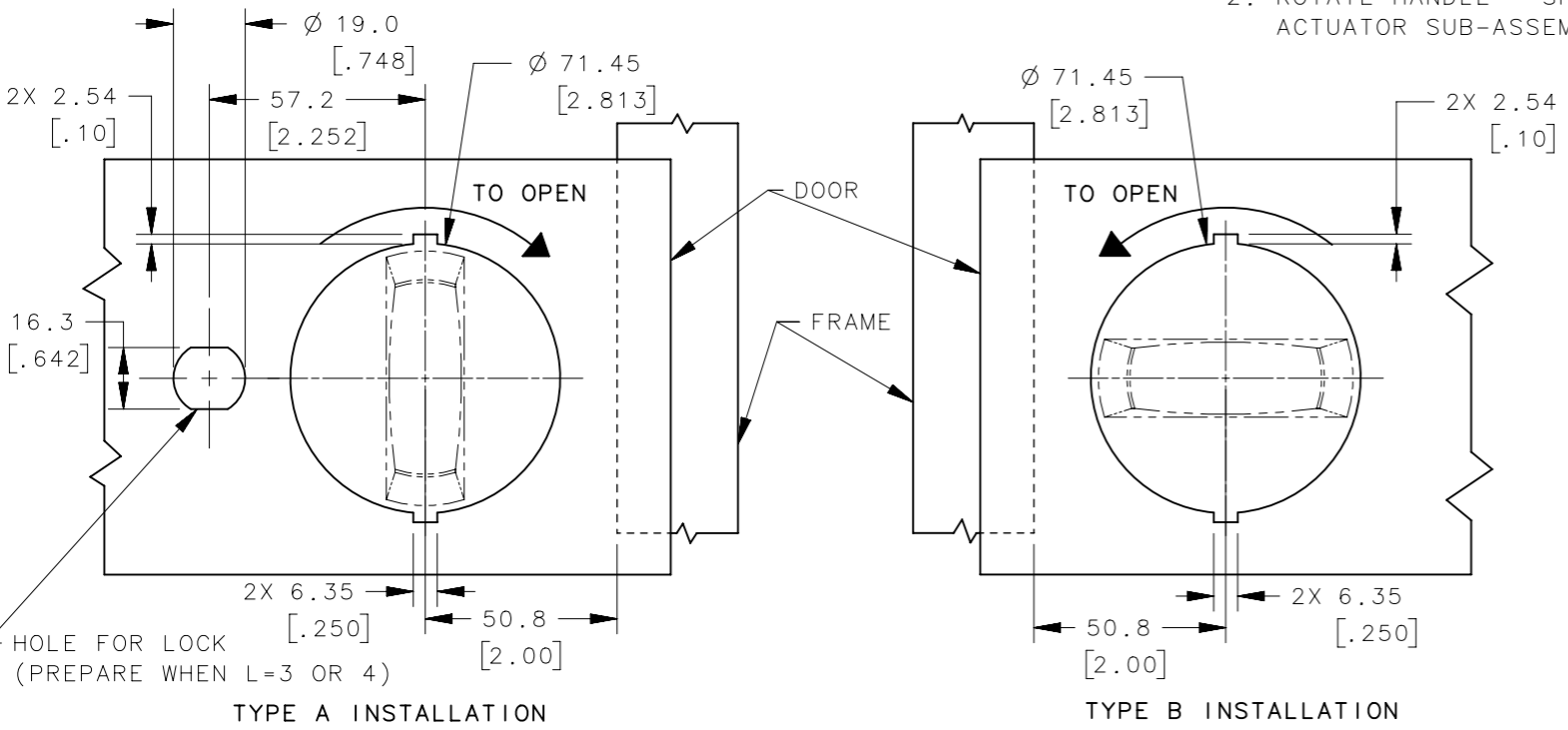

TYPE A INSTALLATION

TYPE B INSTALLATION

PART NUMBER: 01 - L 3 - G F

- LOCK STYLE:
- NON-LOCKING FLAT HANDLE
 - NON-LOCKING FOLDING BAIL HANDLE
 - LOCKING FLAT HANDLE KEYED ALIKE CH751 (TWO KEYS SUPPLIED)
 - LOCKING FOLDING BAIL HANDLE KEYED ALIKE CH751 (TWO KEYS SUPPLIED)

- FINISH:
- BRIGHT CHROME
 - BLACK (FLAT HANDLE ONLY)

GRIP:
 (SEE GRIP TABLE)

THIRD ANGLE PROJECTION

MILLIMETERS [IN]

TOLERANCES UNLESS OTHERWISE NOTED

ALL DIMENSIONS WITHOUT TOLERANCES ARE FOR REFERENCE ONLY.

PER ASME Y14.5M-1994

PROPRIETARY ITEM
 EXCEPT FOR USES EXPRESSLY GRANTED IN WRITING, INFORMATION DISCLOSED HEREON IS CONFIDENTIAL AND ALL RIGHTS, PATENT AND OTHERWISE, ARE RESERVED BY SOUTHCO, INC.

southco
 CONNECT • CREATE • INNOVATE

DESCRIPTION: FLUSH CUP LATCH

SIZE: A3 SYSTEM: NX DWG NO.: J-01-3

DRAWN BY: NBK/DMS DATE: 07DEC2017 SCALE: 1:2 SHEET: 1 OF 1