

Mechanical clamp

ISM-C-ST 175x175x72 12-80

<https://www.schmalz.com/10.01.15.00272>



Part no.: 10.01.15.00272

Homepage > Vacuum Clamping Technology > Clamping Solutions for Woodworking > Modernization of CNC Machining Centers > Innospann Steel-Plate-T > ISMC-ST 175x175x72 12-80

Mechanical clamp for narrow and frame parts, for Steel-Plate-T

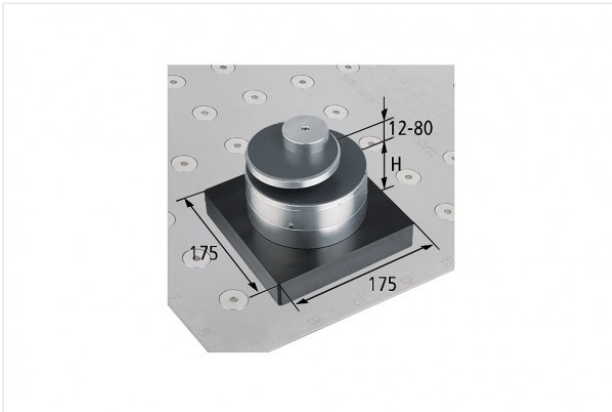

Basic area: 175 x 175 mm mm
Height H: 72 mm
Stroke Z: 10 mm
Clamping range: 12.0 ... 80.0 mm

Design Data

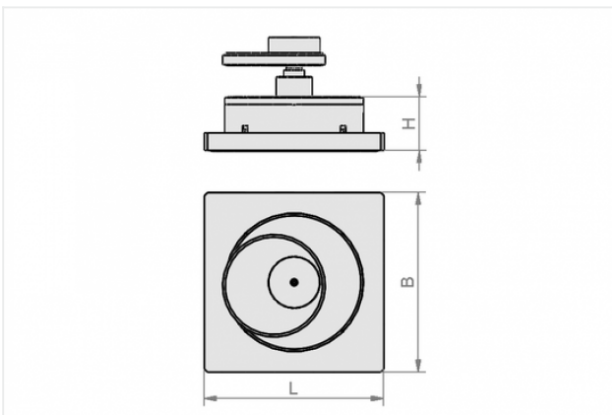

Attribute	Value
-----------	-------

B	175 mm
---	--------

H	72 mm
---	-------

L	175 mm
---	--------

Technical Data

Attribute	Value
-----------	-------

Weight	3.061 kg
--------	----------

Contact to Schmalz

J. Schmalz GmbH | Johannes-Schmalz-Straße, 72293 Glatten, Deutschland | +49 7443 2403-102 | customercenter@schmalz.de



Contact to Schmalz

J. Schmalz GmbH | Johannes-Schmalz-Straße, 72293 Glatten, Deutschland | +49 7443 2403-102 |
customercenter@schmalz.de