

Mechanical clamp

ISMC-ST 175x175x52 12-80

<https://www.schmalz.com/10.01.15.00273>



Part no.: 10.01.15.00273

Homepage > Vacuum Clamping Technology > Clamping Solutions for Woodworking > Modernization of CNC Machining Centers > Innospann Steel-Plate-T > ISMC-ST 175x175x52 12-80

Mechanical clamp for narrow and frame parts, for Steel-Plate-T



Basic area: 175 x 175 mm mm
Height H: 52 mm
Stroke Z: 10 mm
Clamping range: 12.0 ... 80.0 mm

Design Data

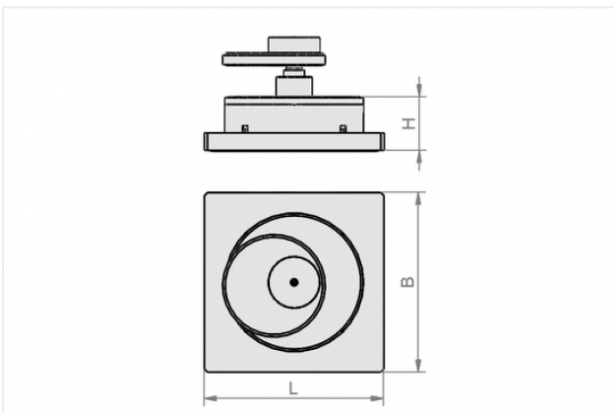

Attribute	Value
-----------	-------

B	175 mm
---	--------

H	52 mm
---	-------

L	175 mm
---	--------

Technical Data

Attribute	Value
-----------	-------

Weight	2.36 kg
--------	---------

Contact to Schmalz

J. Schmalz GmbH | Johannes-Schmalz-Straße, 72293 Glatten, Deutschland | +49 7443 2403-102 | customercenter@schmalz.de

