

Vacuum block

VCBL-S1 120x50x32.7 TV

Part no.: 10.01.12.02319

<https://www.schmalz.com/10.01.12.02319>



Homepage > Vacuum Clamping Technology > Clamping Solutions for Woodworking > Console Table Systems > Clamping Equipment for SCM / Morbidelli Consoles > VCBL-S1 120x50x32.7 TV

Vacuum block for SCM/Morbidelli console - Type 1



Dimensions (LxB): 120 x 50 mm
Height H: 32.7 mm
with: Sensing valve

Design Data

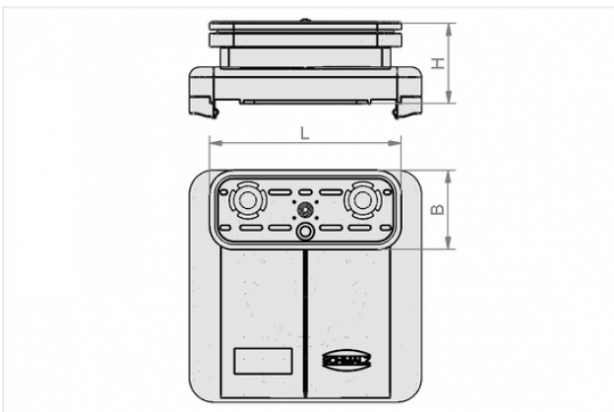

Attribute	Value
-----------	-------

B	50 mm
---	-------

H	32.7 mm
---	---------

L	120 mm
---	--------

Technical Data

Attribute	Value
-----------	-------

Weight	0.313 kg
--------	----------

SCM / Morbidelli is a registered and protected trademark. The articles listed here are products of J. Schmalz GmbH that have been designed to fit CNC machining centers from SCM / Morbidelli.

Contact to Schmalz

J. Schmalz GmbH | Johannes-Schmalz-Straße, 72293 Glatten, Deutschland | +49 7443 2403-102 | customercenter@schmalz.de



[Contact to Schmalz](#)

J. Schmalz GmbH | Johannes-Schmalz-Straße, 72293 Glatten, Deutschland | +49 7443 2403-102 |
customercenter@schmalz.de