

Mechanical clamp

VCMC-K2 154x128x125 10-100

<https://www.schmalz.com/10.01.12.02217>



Part no.: 10.01.12.02217

Homepage > Vacuum Clamping Technology > Clamping Solutions for Woodworking > Clamping Solutions for Narrow Workpieces > Mechanical Clamps > VCMC-K2 154x128x125 10-100

Mechanical clamp for narrow and frame parts, 2-circuit console



Dimensions (LxB): 154 x 128 mm
Height H: 125 mm
Stroke Z: 40 mm
Clamping range: 10.0 ... 100.0 mm

Design Data

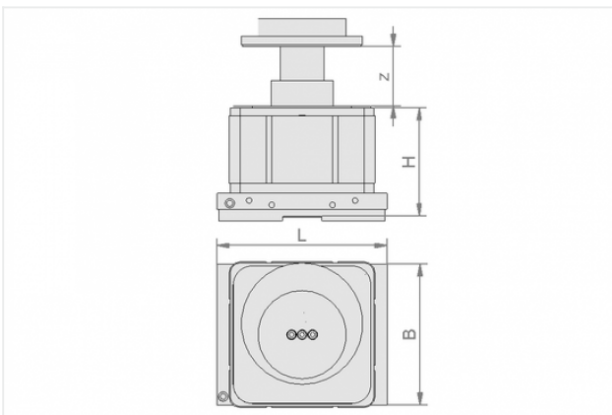

Attribute	Value
-----------	-------

B	128 mm
---	--------

H	125 mm
---	--------

L	154 mm
---	--------

Technical Data

Attribute	Value
-----------	-------

Weight	4.479 kg
--------	----------

Contact to Schmalz

J. Schmalz GmbH | Johannes-Schmalz-Straße, 72293 Glatten, Deutschland | +49 7443 2403-102 | customercenter@schmalz.de

