

# Vacuum block

## VCBL-K2 125x75x125 L

Part no.: 10.01.12.02124

<https://www.schmalz.com/10.01.12.02124>



Homepage > Vacuum Clamping Technology > Clamping Solutions for Woodworking > Console Table Systems > Clamping Equipment for Schmalz  
Consoles (two-circuit) > VCBL-K2 125x75x125 L

### Vacuum block for Schmalz 2-circuit console



Dimensions (LxB): 125 x 75 mm

Height H: 125 mm

Arrangement: longways

### Design Data

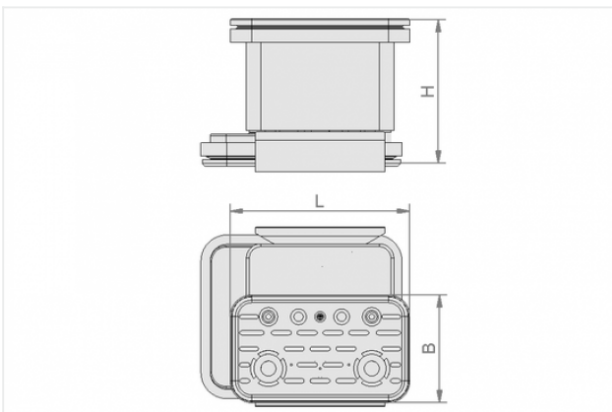

Attribute	Value
-----------	-------

B	75 mm
---	-------

H	125 mm
---	--------

L	125 mm
---	--------

### Technical Data

Attribute	Value
-----------	-------

Weight	0.815 kg
--------	----------

### Contact to Schmalz

J. Schmalz GmbH | Johannes-Schmalz-Straße, 72293 Glatten, Deutschland | +49 7443 2403-102 | [customercenter@schmalz.de](mailto:customercenter@schmalz.de)

