

Mechanical clamp

VCMC-K2 154x128x50 12-80

<https://www.schmalz.com/10.01.12.00737>



Part no.: 10.01.12.00737

Homepage > Vacuum Clamping Technology > Clamping Solutions for Woodworking > Clamping Solutions for Narrow Workpieces > Mechanical Clamps > VCMC-K2 154x128x50 12-80

Mechanical clamp for narrow and frame parts, 2-circuit console



Dimensions (LxB): 154 x 128 mm
Height H: 50 mm
Stroke Z: 10 mm
Clamping range: 12.0 ... 80.0 mm

Design Data

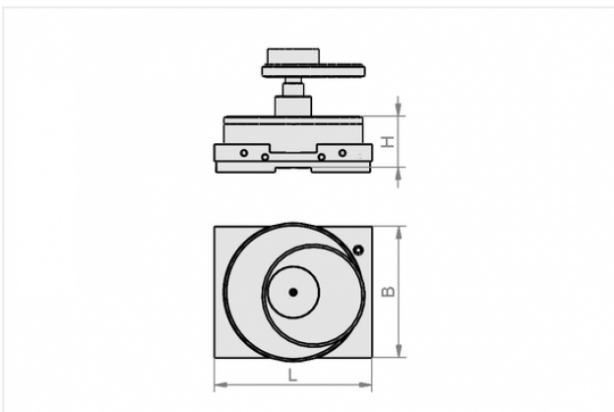

Attribute	Value
-----------	-------

B	128 mm
---	--------

H	50 mm
---	-------

L	154 mm
---	--------

Technical Data

Attribute	Value
-----------	-------

Weight	0.7 kg
--------	--------

Contact to Schmalz

J. Schmalz GmbH | Johannes-Schmalz-Straße, 72293 Glatten, Deutschland | +49 7443 2403-102 | customercenter@schmalz.de

