

Vacuum block

VCBL-K2 120x50x50 D-360

<https://www.schmalz.com/10.01.12.00874>



Part no.: 10.01.12.00874

Homepage > Vacuum Clamping Technology > Clamping Solutions for Woodworking > Console Table Systems > Clamping Equipment for Schmalz Consoles (two-circuit) > VCBL-K2 120x50x50 D-360

Vacuum block for Schmalz 2-circuit console



Dimensions (LxB): 120 x 50 mm
Height H: 50 mm
Arrangement: Can be turned 360°

Design Data

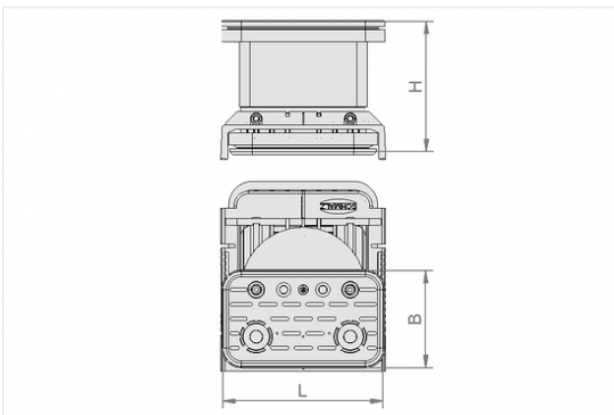

Attribute	Value
B	50 mm
H	50 mm
L	120 mm

Technical Data

Attribute	Value
Weight	0.7 kg

Contact to Schmalz

J. Schmalz GmbH | Johannes-Schmalz-Straße, 72293 Glatten, Deutschland | +49 7443 2403-102 | customercenter@schmalz.de

Spare Parts



VCSP-U 140x115x16.5 VCBL-K2

Part no. 10.01.12.00798

Suction-Plate for vacuum block, bottom

Dimensions (LxB): 140 x 115 mm

Height H: 16.5 mm

for: Vacuum block VCBL-K2