

Mechanical clamp

VCMC-K2 154x128x100

10-100 FI

<https://www.schmalz.com/10.01.12.01962>



Part no.: 10.01.12.01962

Homepage > Vacuum Clamping Technology > Clamping Solutions for Woodworking > Console Table Systems > Clamping Equipment for Schmalz
Consoles (two-circuit) > VCMC-K2 154x128x100 10-100 FI

Mechanical clamp for narrow and frame parts, 2-circuit console



Dimensions (LxB): 154 x 128 mm
Height H: 100 mm
Stroke Z: 40 mm
Clamping range: 10.0 ... 100.0 mm
with: with fixing flap

Design Data

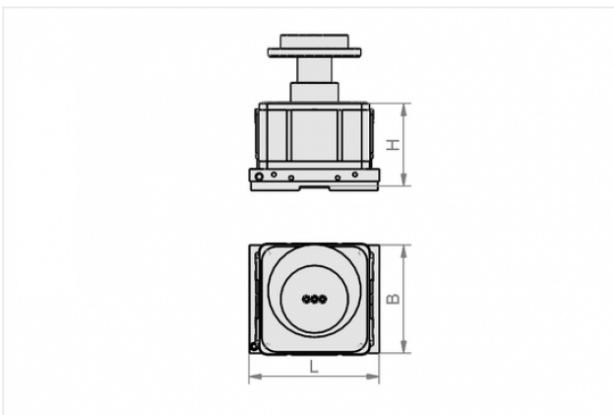

Attribute	Value
-----------	-------

B	128 mm
---	--------

H	100 mm
---	--------

L	154 mm
---	--------

Technical Data

Attribute	Value
-----------	-------

Weight	4.11 kg
--------	---------

Contact to Schmalz

J. Schmalz GmbH | Johannes-Schmalz-Straße, 72293 Glatten, Deutschland | +49 7443 2403-102 |
customercenter@schmalz.de

