

Vacuum block

<https://www.schmalz.com/10.01.12.01020>



VCBL-K2 120x50x100 D-360

Part no.: 10.01.12.01020

Homepage > Vacuum Clamping Technology > Clamping Solutions for Woodworking > Console Table Systems > Clamping Equipment for Schmalz
Consoles (two-circuit) > VCBL-K2 120x50x100 D-360

Vacuum block for Schmalz 2-circuit console



Dimensions (LxB): 120 x 50 mm
Height H: 100 mm
Arrangement: Can be turned 360°

Design Data

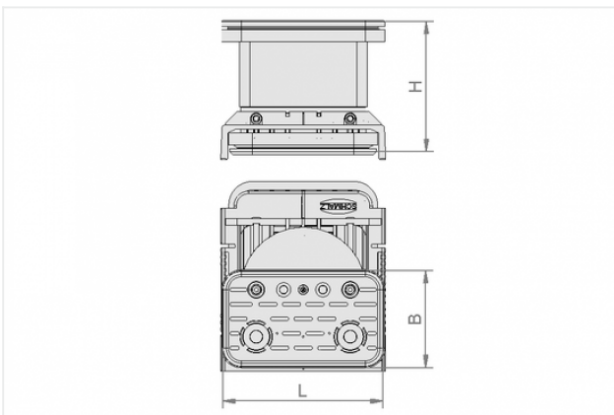

Attribute	Value
-----------	-------

B	50 mm
---	-------

H	100 mm
---	--------

L	120 mm
---	--------

Technical Data

Attribute	Value
-----------	-------

Weight	0.7 kg
--------	--------

Contact to Schmalz

J. Schmalz GmbH | Johannes-Schmalz-Straße, 72293 Glatten, Deutschland | +49 7443 2403-102 | customercenter@schmalz.de

