

# Mechanical clamp

## VCMC-K1 154x128x85 25-100

<https://www.schmalz.com/10.01.12.01926>



Part no.: 10.01.12.01926

Homepage > Vacuum Clamping Technology > Clamping Solutions for Woodworking > Clamping Solutions for Narrow Workpieces > Mechanical Clamps > VCMC-K1 154x128x85 25-100

### Mechanical clamp for narrow and frame parts, 1-circuit console



Dimensions (LxB): 154 x 128 mm  
Height H: 85 mm  
Stroke Z: 25 mm  
Clamping range: 25.0 ... 100.0 mm

### Design Data

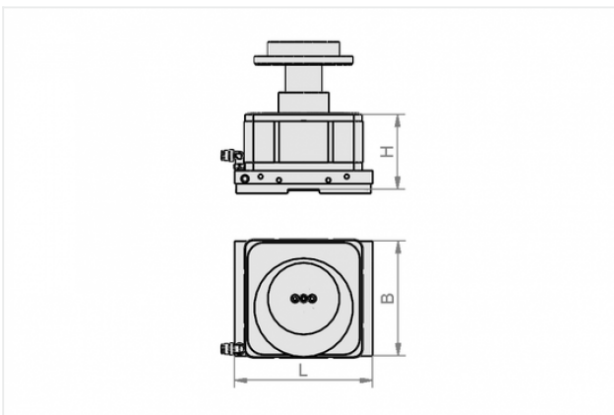

Attribute	Value
-----------	-------

B	128 mm
---	--------

H	85 mm
---	-------

L	154 mm
---	--------

### Technical Data

Attribute	Value
-----------	-------

Weight	3.177 kg
--------	----------

### Contact to Schmalz

J. Schmalz GmbH | Johannes-Schmalz-Straße, 72293 Glatten, Deutschland | +49 7443 2403-102 | [customercenter@schmalz.de](mailto:customercenter@schmalz.de)



---

### Contact to Schmalz

J. Schmalz GmbH | Johannes-Schmalz-Straße, 72293 Glatten, Deutschland | +49 7443 2403-102 |  
customercenter@schmalz.de