

# Vacuum sensor

## VS-V-SD 60 STR4

<https://www.schmalz.com/10.06.02.00259>



Part no.: 10.06.02.00259

Homepage > Vacuum Technology for Automation > Vacuum Components > Switches and System Monitoring > Electronic Vacuum/Pressure Switches > Vacuum Switches VS-V-SD > VS-V-SD 60 STR4

### Miniature vacuum switch with digital output signal



Switching point: - 600 mbar  
Connection: Tube Ø4  
Measuring range: -1.0 ... 0.0 bar  
Cable length: 3 m

### Design Data

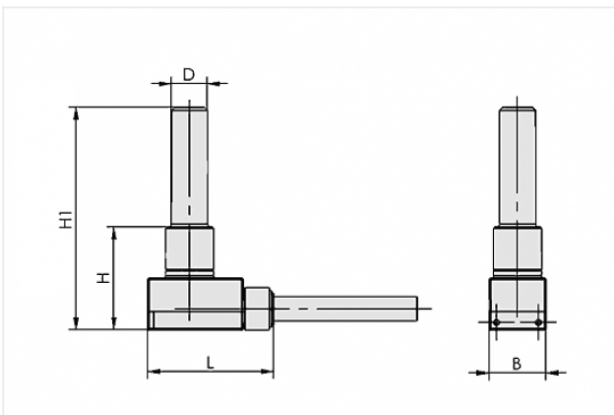

Attribute	Value
-----------	-------

B	9.5 mm
---	--------

D	4 mm
---	------

H	17.2 mm
---	---------

H1	32.2 mm
----	---------

L	21 mm
---	-------

Lk	3 m
----	-----

### Technical Data

Attribute	Value
-----------	-------

Measured medium	Non-aggressive gases; dry, oil-free air
-----------------	---

Measuring range	-1.0 ... 0.0 bar
-----------------	------------------

### Contact to Schmalz

J. Schmalz GmbH | Johannes-Schmalz-Straße, 72293 Glatten, Deutschland | +49 7443 2403-102 | [customercenter@schmalz.de](mailto:customercenter@schmalz.de)

<b>Attribute</b>	<b>Value</b>
Overpressure resistance	5 bar
Repeatability	± 1% of full-scale value
Hysteresis	Fixed: approx. 20 mbar
Inputs/outputs	1 digital
Switching capacity (max)	60 mA
Switching point	- 600 mbar
Indication	LED
Electrical connection	Cable
Connection	Tube Ø4
Voltage	10-24V DC
Protection	IP 40
Temperature influence	± 3% of full-scale value
Ambient temperature	0 ... 50 °C
Weight	5 g

---

---