

# Vacuum centre VZ-OG 165 AC3 200 GMS

Part no.: 10.03.04.00165

<https://www.schmalz.com/10.03.04.00165>



Homepage > Vacuum Technology for Automation > Vacuum Components > Vacuum Generators > Vacuum Centres > Vacuum Centres VZ > VZ-OG 165 AC3 200 GMS

## Vacuum centre with oil-lubricated pump and vacuum reservoir



Suction rate: 165 m<sup>3</sup>/h  
Reservoirs volume: 200 l  
with: Regulated engine circuit  
Voltage: 230/400V ±10%

### Design Data

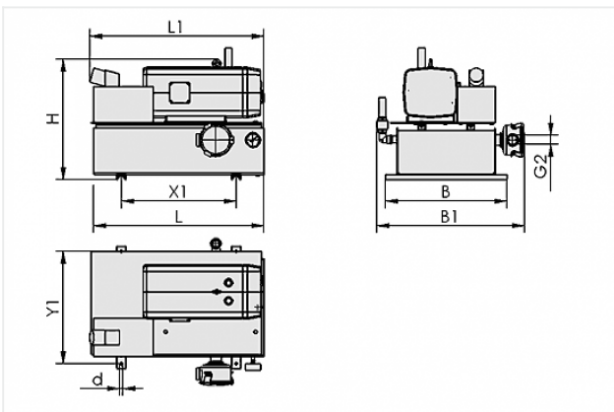

Attribute	Value
-----------	-------

B	710 mm
B1	1040 mm
d	11 mm
G2	G2-1/2"-F
H	950 mm
L	910 mm
L1	1040 mm
X1	592 mm
Y1	670 mm

### Contact to Schmalz

J. Schmalz GmbH | Johannes-Schmalz-Straße, 72293 Glatten, Deutschland | +49 7443 2403-102 | [customercenter@schmalz.de](mailto:customercenter@schmalz.de)

## Technical Data

Attribute	Value
Vacuum (max)	-750 mbar
Voltage	230/400V $\pm$ 10%
Motor power	4 kW
Reservoirs volume	200 l
Protection	IP 44
Weight	273 kg

## Spare Parts



### **FILT-EINS 3 150x222 PAP STF-2-1/2-IG**

Part no. 10.07.01.00020

Filter insert (round)

Filter pore size: 3  $\mu$ m

External diameter D: 150 mm

Length L: 222 mm

Filter material: Paper

for: Filters STF

Size: 2-1/2-IG



### **OEL-FILT EVE-OG-250**

Part no. 10.03.02.00011

Oil filter

for: Pump\_EVE-OG

Size: 250

## Contact to Schmalz



**VST EVE-OG-165-255**

Part no. 10.03.02.00057

Set of parts subject to wear pump

for: Pump\_EVE-OG

Size: 165-255

**Accessories**

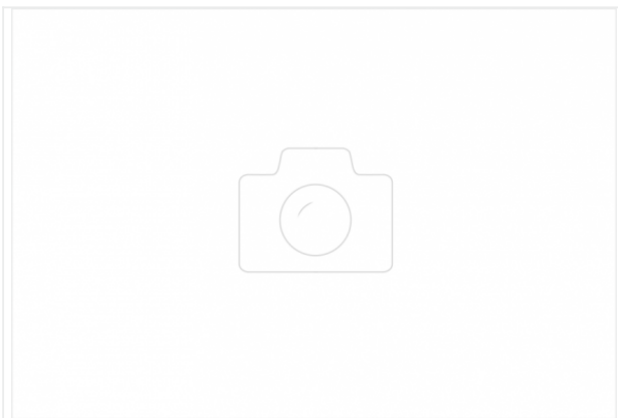

**OEL EVE-OG 1L ANDEROL 555**

Part no. 27.02.01.00055

Oil

for: Pump\_EVE-OG

Volume: 1 l

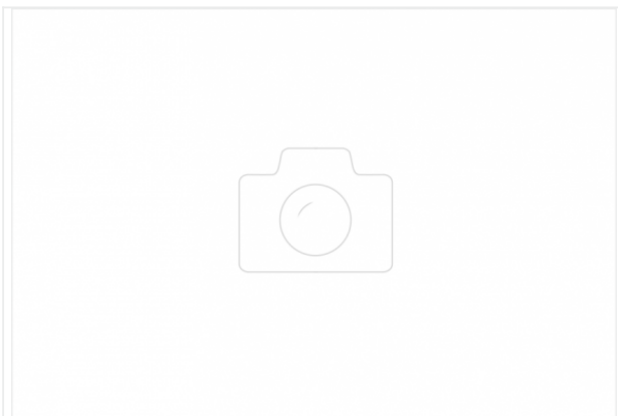

**OEL EVE-OG 5L ANDEROL 555**

Part no. 27.02.01.00056

Oil

for: Pump\_EVE-OG

Volume: 5 l