

Vacuum centre VZ-OG 165 AC3 200 MS

Part no.: 10.03.04.00167

<https://www.schmalz.com/10.03.04.00167>



Homepage > Vacuum Technology for Automation > Vacuum Components > Vacuum Generators > Vacuum Centres > Vacuum Centres VZ > VZ-OG 165 AC3 200 MS

Vacuum centre with oil-lubricated pump and vacuum reservoir



Suction rate: 165 m³/h
Reservoirs volume: 200 l
with: Motor-protection switch
Voltage: 230/400 V, 50 Hz

Design Data

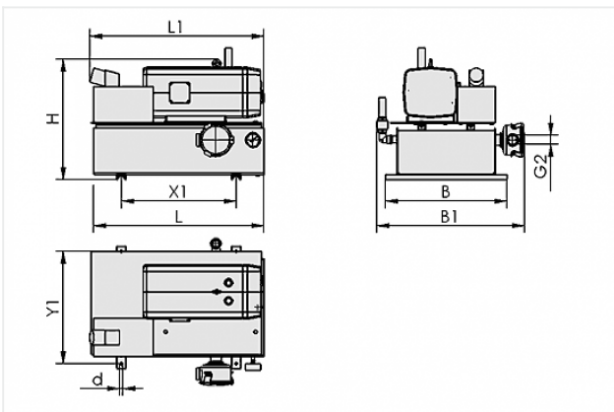

Attribute	Value
B	710 mm
B1	1040 mm
d	11 mm
G2	G2-1/2-F
H	950 mm
L	910 mm
L1	1040 mm
X1	592 mm
Y1	670 mm

Contact to Schmalz

J. Schmalz GmbH | Johannes-Schmalz-Straße, 72293 Glatten, Deutschland | +49 7443 2403-102 | customercenter@schmalz.de

Technical Data

Attribute	Value
Vacuum (max)	-980 mbar
Voltage	230/400 V, 50 Hz
Motor power	4 kW
Reservoirs volume	200 l
Protection	-
Weight	272 kg

Spare Parts



FILT-EINS 3 150x222 PAP STF-2-1/2-IG

Part no. 10.07.01.00020

Filter insert (round)

Filter pore size: 3 µm

External diameter D: 150 mm

Length L: 222 mm

Filter material: Paper

for: Filters STF

Size: 2-1/2-IG

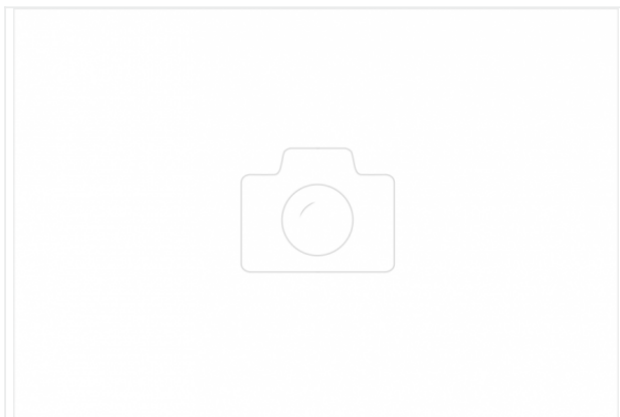

OEL-FILT EVE-OG-250

Part no. 10.03.02.00011

Oil filter

for: Pump_EVE-OG

Size: 250

Contact to Schmalz



VST EVE-OG-165-255

Part no. 10.03.02.00057

Set of parts subject to wear pump

for: Pump_EVE-OG

Size: 165-255

Accessories

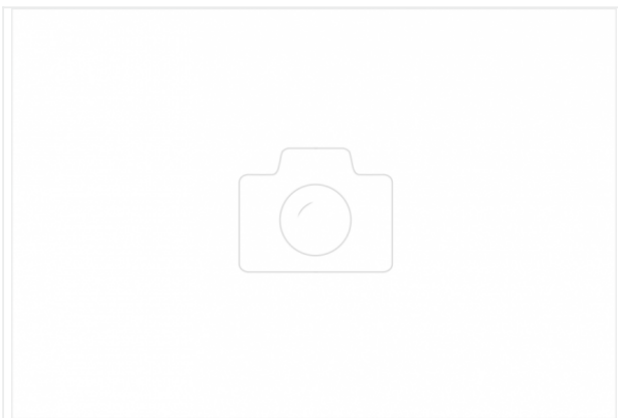

OEL EVE-OG 1L ANDEROL 555

Part no. 27.02.01.00055

Oil

for: Pump_EVE-OG

Volume: 1 l



OEL EVE-OG 5L ANDEROL 555

Part no. 27.02.01.00056

Oil

for: Pump_EVE-OG

Volume: 5 l