

Vacuum centre VZ-OG 100 AC3 100

Part no.: 10.03.04.00139

<https://www.schmalz.com/10.03.04.00139>



Homepage > Vacuum Technology for Automation > Vacuum Components > Vacuum Generators > Vacuum Centres > Vacuum Centres VZ > VZ-OG 100 AC3 100

Vacuum centre with oil-lubricated pump and vacuum reservoir



Suction rate: 100 m³/h
Voltage: 230/400 V, 50 Hz
Reservoirs volume: 100 l

Design Data

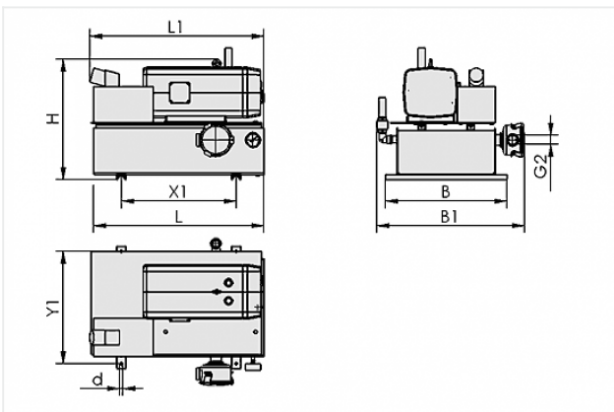

Attribute	Value
-----------	-------

B	610 mm
---	--------

B1	750 mm
----	--------

d	11 mm
---	-------

G2	G1-1/4-F
----	----------

H	700 mm
---	--------

L	710 mm
---	--------

L1	750 mm
----	--------

X1	480 mm
----	--------

Y1	570 mm
----	--------

Contact to Schmalz

J. Schmalz GmbH | Johannes-Schmalz-Straße, 72293 Glatten, Deutschland | +49 7443 2403-102 | customercenter@schmalz.de

Technical Data

Attribute	Value
Vacuum (max)	-980 mbar
Voltage	230/400 V, 50 Hz
Motor power	2.2 kW
Reservoirs volume	100 l
Protection	IP 54
Weight	129.5 kg

Spare Parts



ERS-SET EVE-OG 63+100

Part no. 10.03.02.00012

Set of filters

for: Pump_EVE-OG

Size: 63+100



FILT-EINS 3 98x70 PAP STF-1-1/4-IGN

Part no. 10.07.01.00018

Filter insert (round)

Filter pore size: 3 µm

External diameter D: 98 mm

Length L: 70 mm

Filter material: Paper

for: Filters STF

Size: 1-1/4-IGN

Contact to Schmalz



OEL-FILT EVE-OG-40-100G

Part no. 10.03.02.00009

Oil filter

for: Pump_EVE-OG

Size: 40-100G

Accessories

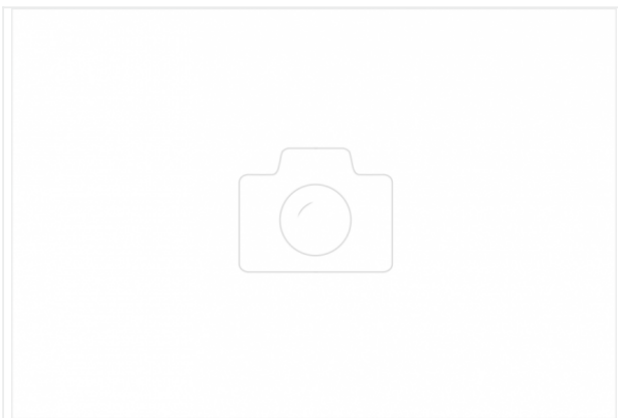

OEL EVE-OG 1L ANDEROL 555

Part no. 27.02.01.00055

Oil

for: Pump_EVE-OG

Volume: 1 l