

# Vacuum centre VZ-OG 63 AC3 100 GMS

Part no.: 10.03.04.00121

<https://www.schmalz.com/10.03.04.00121>



Homepage > Vacuum Technology for Automation > Vacuum Components > Vacuum Generators > Vacuum Centres > Vacuum Centres VZ > VZ-OG 63 AC3 100 GMS

## Vacuum centre with oil-lubricated pump and vacuum reservoir



Suction rate: 63 m<sup>3</sup>/h  
Reservoirs volume: 100 l  
with: Regulated engine circuit  
Voltage: 230/400V ±10%

### Design Data

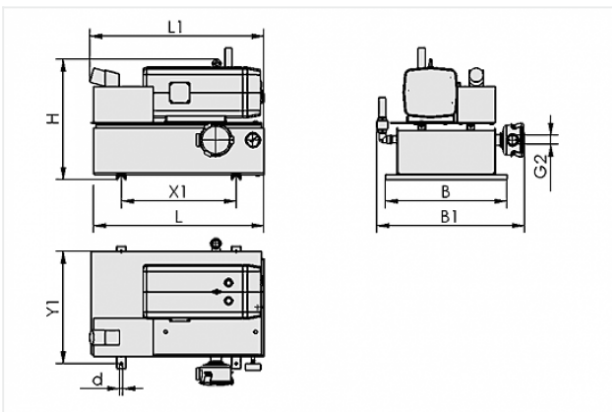

Attribute	Value
-----------	-------

B	610 mm
---	--------

B1	750 mm
----	--------

d	11 mm
---	-------

G2	G1-1/4"-F
----	-----------

H	700 mm
---	--------

L	710 mm
---	--------

L1	720 mm
----	--------

X1	480 mm
----	--------

Y1	570 mm
----	--------

### Contact to Schmalz

J. Schmalz GmbH | Johannes-Schmalz-Straße, 72293 Glatten, Deutschland | +49 7443 2403-102 | [customercenter@schmalz.de](mailto:customercenter@schmalz.de)

## Technical Data

Attribute	Value
Vacuum (max)	-750 mbar
Voltage	230/400V ±10%
Motor power	1.5 kW
Reservoirs volume	100 l
Protection	IP 44
Weight	113.5 kg

## Spare Parts



### OEL-FILT EVE-OG-40-100G

Part no. 10.03.02.00009

Oil filter

for: Pump\_EVE-OG

Size: 40-100G



### ERS-SET EVE-OG 63+100

Part no. 10.03.02.00012

Set of filters

for: Pump\_EVE-OG

Size: 63+100

## Contact to Schmalz



**FILT-EINS 3 98x70 PAP STF-1-1/4-IGN**

Part no. 10.07.01.00018

Filter insert (round)

Filter pore size: 3 µm

External diameter D: 98 mm

Length L: 70 mm

Filter material: Paper

for: Filters STF

Size: 1-1/4-IGN

**Accessories**



**OEL EVE-OG 1L ANDEROL 555**

Part no. 27.02.01.00055

Oil

for: Pump\_EVE-OG

Volume: 1 l