

Vacuum blower

SB 1250 270 13.2 IE3-TYP2

<https://www.schmalz.com/10.04.01.00086>



Part no.: 10.04.01.00086

Homepage > Vacuum Technology for Automation > Vacuum Components > Vacuum Generators > Vacuum Blowers > Vacuum Blowers SB > SB 1250 270 13.2 IE3-TYP2

Vacuum Blower for high suction rate



Suction rate (60 Hz): 1250 m³/h
Vacuum (60Hz): 270 mbar
Rated power (60 Hz): 13.2 kW
Construction: IE3:US/CAN
Voltage (60 Hz): YY230/Y460V ±10%
Permission: IE3/UL/CSA
Weight: 125 kg

Design Data

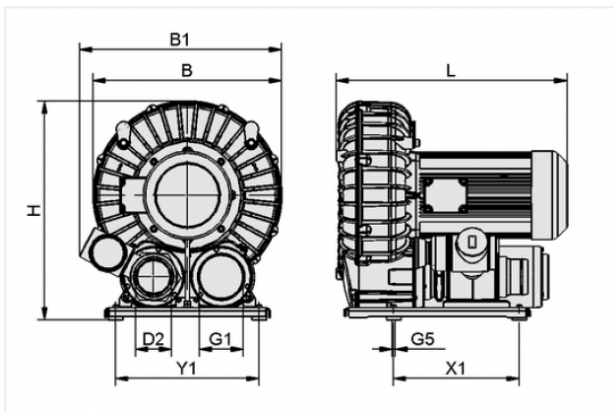

| Attribute | Value |
|-----------|-------|
|-----------|-------|

| | |
|---|--------|
| B | 525 mm |
|---|--------|

| | |
|----|--------|
| B1 | 563 mm |
|----|--------|

| | |
|----|-------|
| D2 | 98 mm |
|----|-------|

| | |
|----|-------|
| G1 | G4"-F |
|----|-------|

| | |
|----|------|
| G5 | M8-F |
|----|------|

| | |
|---|--------|
| H | 611 mm |
|---|--------|

| | |
|---|--------|
| L | 643 mm |
|---|--------|

| | |
|----|--------|
| X1 | 350 mm |
|----|--------|

| | |
|----|--------|
| Y1 | 400 mm |
|----|--------|

Contact to Schmalz

J. Schmalz GmbH | Johannes-Schmalz-Straße, 72293 Glatten, Deutschland | +49 7443 2403-102 | customercenter@schmalz.de

Technical Data

| Attribute | Value |
|----------------------|------------------------|
| Suction rate (60 Hz) | 1250 m ³ /h |
| Suction rate (60 Hz) | 20,833.2 l/min |
| Vacuum (60Hz) | 270 mbar |
| Protection | IP 55 |
| Rated power (60 Hz) | 13.2 kW |
| Noise level (60 Hz) | 79 dB |
| Weight | 125 kg |
