

Vacuum blower

SB 160 115 0.9 IE3-TYP2

Part no.: 10.04.01.00068

<https://www.schmalz.com/10.04.01.00068>



Homepage > Vacuum Technology for Automation > Vacuum Components > Vacuum Generators > Vacuum Blowers > Vacuum Blowers SB > SB 160 115 0.9 IE3-TYP2

Vacuum Blower for high suction rate



Suction rate (60 Hz): 160 m³/h
Vacuum (60Hz): 115 mbar
Rated power (60 Hz): 0.9 kW
Construction: IE3:US/CAN
Voltage (60 Hz): YY230/Y460V ±10%
Permission: IE3/UL/CSA
Weight: 21.7 kg

Design Data

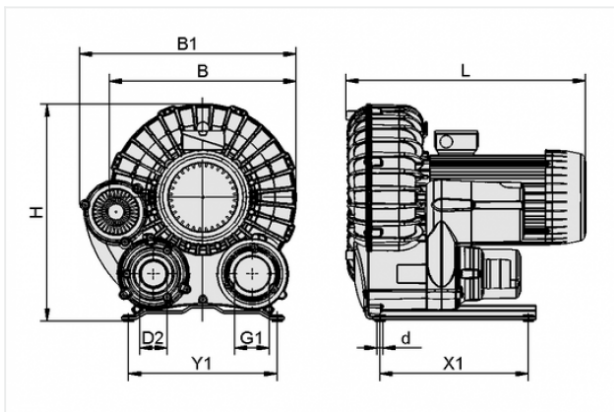

Attribute	Value
-----------	-------

B	264 mm
B1	295.3 mm
d	10.2 mm
D2	40 mm
G1	G1-1/2"-F
H	309 mm
L	387 mm
X1	240 mm
Y1	240 mm

Contact to Schmalz

J. Schmalz GmbH | Johannes-Schmalz-Straße, 72293 Glatten, Deutschland | +49 7443 2403-102 | customercenter@schmalz.de



Technical Data

Attribute	Value
Suction rate (60 Hz)	160 m ³ /h
Suction rate (60 Hz)	2,666.6 l/min
Vacuum (60Hz)	115 mbar
Protection	IP 55
Rated power (60 Hz)	0.9 kW
Noise level (60 Hz)	61.7 dB
Weight	21.7 kg

Contact to Schmalz