

Vacuum pump EVE-OG 165 AC3 F

Part no.: 10.03.02.00049

<https://www.schmalz.com/10.03.02.00049>



Homepage > Vacuum Technology for Automation > Vacuum Components > Vacuum Generators > Vacuum Pumps > Oil-Lubricated Vacuum Pumps EVE-OG > EVE-OG 165 AC3 F

Oil-lubricated pump for maximum vacuum levels, requires little maintenance



Current type: 3-phase AC
 Noise level: 70 dB
 with: Filter
 Voltage (50Hz): 200-240V or 345-420V
 Suction rate (50Hz): 165 m³/h
 Rated power (50Hz): 4 kW
 Weight: 140 kg

Design Data

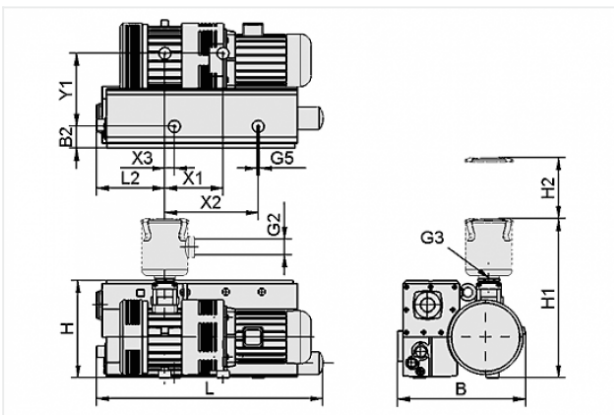

Attribute	Value
-----------	-------

B	554 mm
B2	92 mm
G2	G2-1/2-F
G3	G2-F
G5	M10-F
H	418 mm
H1	680 mm
H2	240 mm
L	921 mm
L2	285 mm
X1	243 mm
X2	390 mm
X3	40 mm

Contact to Schmalz

J. Schmalz GmbH | Johannes-Schmalz-Straße, 72293 Glatten, Deutschland | +49 7443 2403-102 | customercenter@schmalz.de

Attribute	Value
Y1	305 mm

Technical Data

Attribute	Value
Vacuum (max)	-980 mbar
Vacuum (max)	-28.939 inHg
Suction rate (50 Hz)	165 m ³ /h
Voltage (50 Hz)	200-240V or 345-420V
Rated power (50 Hz)	4 kW
Noise level (50 Hz)	70 dB
Weight	140 kg
Protection	IP 54
Current type	AC3

Spare Parts



FILT-EINS 3 150x222 PAF STF-2-1/2-IG

Part no. 10.07.01.00020

Filter insert (round)

Filter pore size: 3 µm

External diameter D: 150 mm

Length L: 222 mm

Filter material: Paper

for: Filters STF

Size: 2-1/2-IG



OEL EVE-OG 5L ANDEROL 555

Part no. 27.02.01.00056

Oil

for: Pump_EVE-OG

Volume: 5 l



VST EVE-OG-165-255

Part no. 10.03.02.00057

Set of parts subject to wear pump

for: Pump_EVE-OG

Size: 165-255

Accessories



MSS-K 8-12A

Part no. 10.04.04.00123

Motor-protection switch with housing

Current range: 8.0 ... 12.0 A

Actuation: Rotary switch

Colour: grey

Protection: IP 65

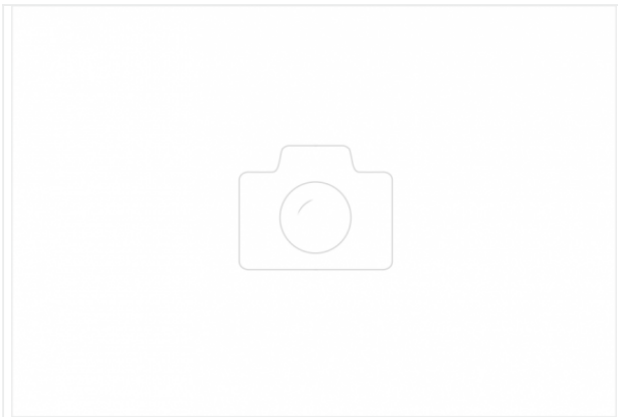
**DRM 40 P1 H**

Part no. 10.07.02.00051

Pressure manometer for analogue measurement and monitoring of the pressure

External diameter D: 40 mm

Measuring range: 0.0 ... 1.0 bar

Shape: Connection at rear

Pressure inlet: G1-M

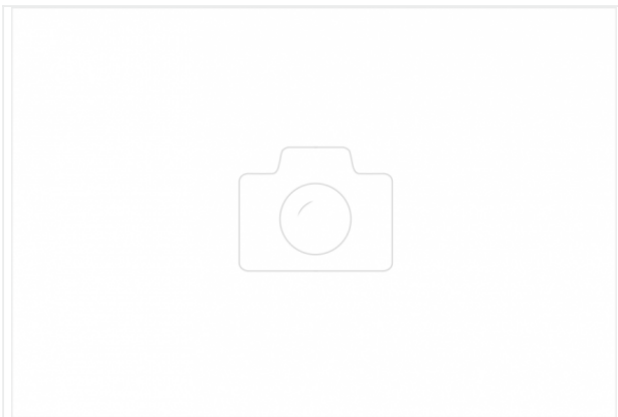
**OEL EVE-OG 1L ANDEROL 555**

Part no. 27.02.01.00055

Oil

for: Pump_EVE-OG

Volume: 1 l

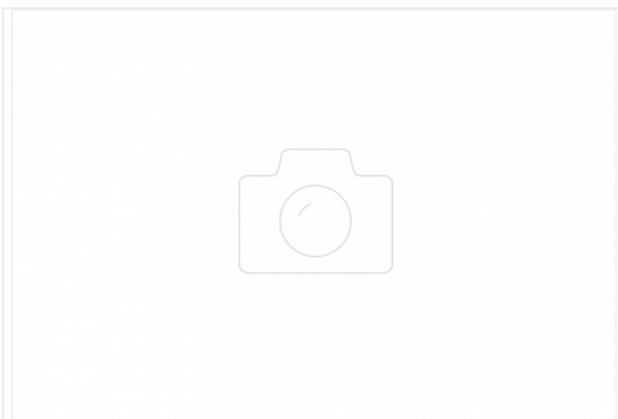
**OEL EVE-OG 5L ANDEROL 555**

Part no. 27.02.01.00056

Oil

for: Pump_EVE-OG

Volume: 5 l