

# Vacuum pump EVE-OG 63 AC3 F

Part no.: 10.03.02.00032

<https://www.schmalz.com/10.03.02.00032>



Homepage > Vacuum Technology for Automation > Vacuum Components > Vacuum Generators > Vacuum Pumps > Oil-Lubricated Vacuum Pumps EVE-OG > EVE-OG 63 AC3 F

## Oil-lubricated pump for maximum vacuum levels, requires little maintenance



Current type: 3-phase AC  
Noise level: 65 dB  
with: Filter  
Voltage (50Hz): 200-240V or 345-420V  
Suction rate (50Hz): 63 m<sup>3</sup>/h  
Rated power (50Hz): 1.5 kW  
Weight: 52 kg

### Design Data

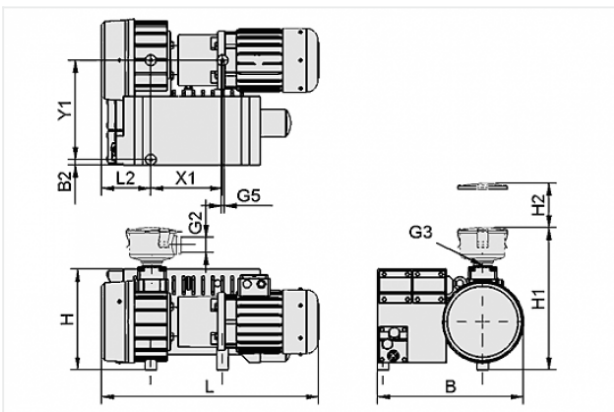

Attribute	Value
-----------	-------

B	406 mm
---	--------

B2	15 mm
----	-------

G2	G1-1/4"-F
----	-----------

G3	G1-1/4"-F
----	-----------

G5	M8-F
----	------

H	280 mm
---	--------

H1	417 mm
----	--------

H2	75 mm
----	-------

L	614 mm
---	--------

L2	137 mm
----	--------

X1	199 mm
----	--------

Y1	277 mm
----	--------

### Contact to Schmalz

J. Schmalz GmbH | Johannes-Schmalz-Straße, 72293 Glatten, Deutschland | +49 7443 2403-102 | [customercenter@schmalz.de](mailto:customercenter@schmalz.de)

## Technical Data

Attribute	Value
Vacuum (max)	-980 mbar
Vacuum (max)	-28.939 inHg
Suction rate (50 Hz)	63 m <sup>3</sup> /h
Voltage (50 Hz)	200-240V or 345-420V
Rated power (50 Hz)	1.5 kW
Noise level (50 Hz)	65 dB
Weight	52 kg
Protection	IP 54
Current type	AC3

## Spare Parts



### **FILT-EINS 3 98x70 PAP STF-1-1/4-IGN**

Part no. 10.07.01.00018

Filter insert (round)

Filter pore size: 3 µm

External diameter D: 98 mm

Length L: 70 mm

Filter material: Paper

for: Filters STF

Size: 1-1/4-IGN



**VST EVE-OG-63-100**

Part no. 10.03.02.00055

Set of parts subject to wear pump

for: Pump\_EVE-OG

Size: 63-100

**Accessories**



**DRM 40 P1 H**

Part no. 10.07.02.00050

Pressure manometer for analogue measurement and monitoring of the pressure

External diameter D: 40 mm

Measuring range: 0.0 ... 1.0 bar

Shape: Connection at rear

Pressure inlet: G3/4-M



**MSS-K 4-6.3A**

Part no. 10.04.04.00121

Motor-protection switch with housing

Current range: 4.0 ... 6.3 A

Actuation: Rotary switch

Colour: grey

Protection: IP 65

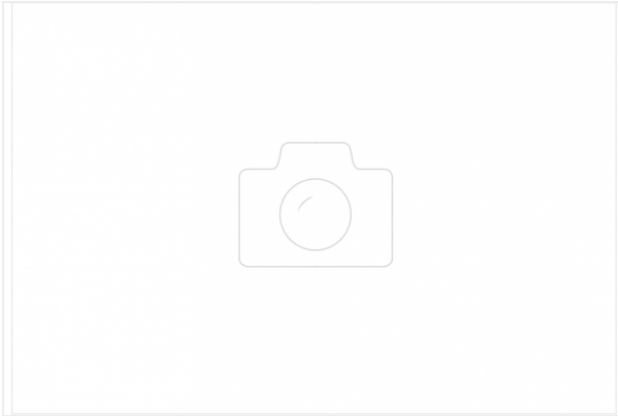

**OEL EVE-OG 1L ANDEROL 555**

Part no. 27.02.01.00055

Oil

for: Pump\_EVE-OG

Volume: 1 l